

CIL Navikarniya Urja Limited
(A Subsidiary Company of Coal India Limited)

Tender

DocumentFor

**Design, Engineering, Procurement & Supply, Construction & Erection, Testing,
Commissioning, Associated Transmission System and Comprehensive O&M for 5 Years of
20MW (AC) Solar PV Power Plant at**

Dugdha Washery Area, BCCL

Dhanbad, Jharkhand, India.

**(Only through limited e-Tender mode for the CIL Empaneled EPC Contractors for Solar
Projects)**



CIL Navi Karniya Urja
Limited 7th Floor, Coal Bhawan,
Premises

No-4 MAR Action Area –
1A, New Town, Rajarhat,
Kolkata (WB) – 700156

Email:

ceo.cnul@coalindia.in

About the Company

CIL Navikarniya Urja Limited (CNUL), a wholly owned subsidiary company of Coal India Limited was incorporated on 16th of April,2021 to venture into new business area of New and Renewable Energy (Non-Conventional) segment including Solar, Wind, Small Hydro, Biomass, Geo-Thermal, Hydrogen, Tidal, etc., along with other prevalent technologies/emerging technologies for development of non-conventional/clean & renewal energy Business.

Parent company Coal India Limited (CIL) is the state-owned coal mining corporate came into being in November 1975 is at the forefront of the nation's coal production in the Indian energy sector. CIL alone produces around 83% of country's entire coal output. In a country where 69% of the total electricity generation is coal based, CIL virtually empowers the nation's power sector. Around 80% of CIL's total supplies are catered to power sector.

Bharat Coking Coal Limited (BCCL) is the wholly owned subsidiary Company of CIL. BCCL intends for Development of **20 MW (AC)** Grid Connected SolarPV Project at one location of Dugdha Washery area, BCCL, Dhanbad, India. CNUL has been awarded the job of providing PMC service for developing the 20 MW project through engagement of EPC Contractor.

The generated solar power from the proposed solar project will be utilized by BCCL for captive consumption. CNUL endeavors to reduce energy charge of the Subsidiary by installing the proposed solar project.

About the Project

The envisaged 20 MW (AC)/ 28 MW(DC) Solar Power plant will be established through EPC contractor at one location of Dugdha Washery area, BCCL, Dhanbad, India.

- BCCL has planned to evacuate the Power generated from the Solar Plant at Dugdha to the nearest DVC Sub-station, namely: Chandrapura Super Thermal Power Station (CSTPS) – which is at a distance of 6 km from the project site at 33 kV. BCCL will obtain necessary permission/ approval from DVC for evacuation arrangement.
- Installation, Testing and Commissioning of the 20 MW (AC)/ 28 MWp(DC) Solar Plant along with Transmission line / cable from plant take off point to the interconnecting substations and bay(s) at substations shall be **in the scope of EPC Contractor**. The EPC Contractor will also maintain the OHTLs during O&M period of 5 years at the cost of EPC Contractor. Safety, security, maintenance and operation of the said transmission line upto 5 years O&M period will be the sole responsibility of the EPC Contractor.
- Any other statutory approval, if required to be taken during execution of the project, will be taken by the EPC Contractor at it's own cost. BCCL and CNUL shall extend required help to the EPC Contractor for obtaining such statutory approval.
- CNUL (on behalf of BCCL) now issues this Tender for selection of EPC-cum-O&M contractor for the entire EPC work for the Project as well as O&M of the Project for 5 years after the project Commissioning date (COD) (to be executed through **BCCL** after awarding work by **BCCL**. CNUL will be responsible for providing award recommendation of the work to the selected EPC Contractor.
- Post-award activities, such as signing of contract agreement, contract execution, payment and other activities will be under **BCCL's** scope. CNUL will provide PMC service during commissioning period as per the agreement between BCCL and CNUL.

CONTENTS

SECTION	TITLE	FROM	TO
1	e-TENDER NOTICE	5	20
2	GENERAL TERMS AND CONDITIONS OF CONTRACT	21	48
3	ADDITIONAL TERMS AND CONDITIONS OF CONTRACT	49	49
4	GENERAL TECHNICAL CONDITIONS	50	60
5	ERECTION CONDITIONS OF CONTRACT	61	78
6	SPECIAL CONDITIONS OF CONTRACT	79	106
7	SAFETY CODE	107	111
8	BID SUBMISSION CHECKLIST	112	112
APPENDIX 1	FORMAT OF LETTER OF BID	113	114
APPENDIX 2	DETAILS OF SITE	115	115
APPENDIX 3	FORMAT FOR BANK GUARANTEE	117	120
APPENDIX 4	PRE-CONTRACT INTEGRITY PACT	121	127
APPENDIX 5	ILLUSTRATIVE COMPUTATION OF EVALUATED BID VALUE (EBV)	128	130
APPENDIX 6	FORMAT FOR PRE-BID QUERIES	131	131
APPENDIX 7	MANDATE FORM FOR EFT	132	133
APPENDIX 8	FORMAT FOR POWER OF ATTORNEY	134	135
APPENDIX 9	PROFORMA FOR EXECUTION OF AGREEMENT	136	137
APPENDIX 10	PROFORMA OF MEMORANDUM	138	138
APPENDIX 11	TECHNICAL SPECIFICATIONS	139	139
APPENDIX 12	BID SECURING DECLARATION	140	140
APPENDIX 13	PROFORMA FOR WRITTEN CONSENT FOR ARBITRATION CLAUSE	141	143
APPENDIX 14	PROFORMA FOR UNDERTAKING	144	145
APPENDIX 15	FORMAT FOR DETAILED PROJECT SCHEDULE	146	146
APPENDIX 16	VALID DIGITAL SIGNATURE CERTIFICATE	147	147
APPENDIX 17	GUIDELINES FOR BANNING OF BUSINESS	148	149
APPENDIX 18	NO DEMAND CERTIFICATE	150	150
APPENDIX 19	PROFORMA OF BANK GUARANTEE FOR MOBILISATION	151	152

e-TENDER NOTICE

1. Tenders are invited on-line on the website <https://coalindiatenders.nic.in> from the empaneled bidders having Digital Signature Certificate (DSC) issued from any agency authorized by Controller of Certifying Authority (CCA), Govt. of India and which can be traced up to the chain of trust to the RootCertificate of CCA, for the following work:

Description of work	Estimated Cost of Work (Including GST) (In INR)	Earnest Money (In INR)	Period of Completion(In Days)
(i) Design, Engineering, Procurement and Supply, Construction, Erection, Testing and Commissioning of 20 MW (AC) Solar PV Power Plant at Dugdha Washery Area (20 MW) of BCCL, Dhanbad, India; (ii) Erection, Installation, Testing and Commissioning of 6 kM Transmission System from project site to injection point (CSTPS- DVC). (iii) Comprehensive O&M of the plant and the associated transmission system for 5 Years thereafter.	Rs. 145,77,07,000/- (INR 145.7707 Cr) (inclusive of Supply cost, Work Cost and NPV of O&M cost for 5 years)	Rs. 50,00,000/- (INR 50 Lakh)	Total contract period: 2190 Days a) From date of commencement to COD: 12 Months (i.e. 365 days) b) Operation and Maintenance of Project: 1825 Days (i.e. 5 years) from COD

Guaranteed Energy and CUF Requirement:

Sl No.	Parameter	Value
1.	Net Electrical Energy Guaranteed Generation (NEEGG)	37.43 MU for first year with allowable degradation of 0.7% in subsequent year's w.r.t. immediate last year.
2.	Capacity Utilization Factor (CUF)	21.67 % for first year with allowable degradation of 0.7% in subsequent year w.r.t. immediate last year.

Tender inviting authority	Contact Person(s)/Tender Dealing Officer(s)
B K Panda, GM (E&M)/ Solar Tel: +91-8249931609 Email: bkpanda.cil@coalindia.in	Soumitra Roy General Manager (E&M), BCCL Tel: +91- 9470595663 Email: gmenm.bccl@coalindia.in

Tender inviting authority	Contact Person(s)/Tender Dealing Officer(s)
	<p>Atanu Nandi Chief Manager (E&M), Solar Tel: +91-8908647978 Email: a.nandi@coalindia.in</p> <p>Subhajyoti Jana Manager (E&M), Solar Cell Tel: +91-9434797102 Email: subhajyoti.jana@coalindia.in</p> <p>Abhinav Kumar Dy. Manager (E&M), Solar Cell Tel: +91 9433031045 Email: abhinavk.cil@coalindia.in</p>
<p>For any Portal related queries please call at 24 x 7 Help Desk Number- 0120-4001 002, 0120-4001 005, 0120-6277 787</p>	

2. Time Schedule of Tender:

As per Portal.

Note: The auto extension of submission of bid shall be applicable as per details mentioned in clause no.14 of NIT.

3. Earnest Money Deposit:

The bidder will have to make the payment of EMD through ONLINE mode only.

3.1.1 In Online mode the bidder can make **payment** of EMD either through **NET-BANKING** from designated Bank(s) or through **NEFT/RTGS** from any scheduled Bank(s).

3.1.2 NET-BANKING: In case of payment through net-banking the money will be immediately transferred to CIL/ Subsidiary's designated Account.

3.1.3 NEFT/RTGS: In case of payment through NEFT/RTGS from any scheduled bank(s), the bidder will have to make payment as per the Challan(s) generated by system on e- Procurement portal. **The** payment of EMD through NEFT/RTGS mode should be made well ahead of time to ensure that the EMD amount is transferred to CIL/ Subsidiary account before submission of bid.

3.1.4 NOTE 1: After successful payment of EMD either through Net Banking or NEFT/RTGS, bidder is advised to log on to <https://coalindiatenders.nic.in> and click on "**Payment Verification Button**" to check the transaction status of EMD.

NOTE 2: Bidder is advised **not to pay EMD through IMPS mode** as such payments are not acceptable for submission of bid by the system.

NOTE 3: In case of payment of EMD through NEFT/RTGS mode, bidder needs to pay the EMD from the scheduled bank by visiting their branch.

3.1.5 The Bidder will be allowed to submit his/her/their bid only when the EMD is successfully received in CIL/ Subsidiary's designated account and the information flows from Bank to e-Procurement system.

3.1.6 In online payment of EMD, if the payment is made by the bidder within the last date and time of bid submission but not received by CIL/ Subsidiary within the specified period due to any reason(s) whatsoever then the bid will not be accepted. However, the EMD will be refunded back to the bidder.

Note: If any information and document submitted by the bidder is found to be false/ incorrect at any time, department may cancel their Bid and action as deemed fit may be taken against them, including termination of the contract, forfeiture of all dues including Earnest Money and banning of the firm and all partners of the firm.

3.1.7 EMD Exemption:

Micro and Small Enterprises (MSEs) as defined in MSE Procurement Policy issued by Department of Micro, Small and Medium Enterprises (MSME) will be exempted from the payment of earnest money (**Applicable for Service Nature of Job**).

In case of exemption of EMD, the scanned copy of document (attested by notary public) in support of exemption will have to be uploaded by the bidder during bid submission. However, this option is to be enabled only in those cases where the exemption of EMD to some bidders is allowed as per NIT.

4. Pre-bid Meeting:

The pre-bid meeting shall be held physically in CIL HQ, Kolkata as per the scheduled date & time, as specified in the e-Procurement portal. The purpose of the pre-bid meeting is to clarify the issues and to answer the questions on any matter that may be raised at that stage. Non-attendance at the pre-bid meeting will not be a cause for disqualification of bidder and it shall be presumed that the bidder does not require any clarification. If a Pre Bid meeting is held then the minutes of the Pre-Bid meeting shall be uploaded on the Portal, which can be viewed by all interested bidders.

5. Clarification of Bid:

The bidder may seek clarification on-line within the specified period. However, the management will clarify as far as possible to the relevant queries.

The identity of the Bidder will not be disclosed by the system. The clarifications given by department will be visible to all the bidders intending to participate in that tender. The clarifications may be asked from the day of e-Publication of NIT. The period for seeking clarification by bidder will be up to 7 (Seven) days before the end date of bid submission. The replies to clarifications sought by bidders should be given by the department at least 2 (Two) days before the end date of bid submission.

6. User Portal Agreement:

The bidders have to accept the on-line user portal agreement which contains the acceptance of all the Terms and Conditions of NIT and tender document, undertakings and the e-Procurement system through <https://coalindiatenders.nic.in> in order to become an eligible bidder. This will be a part of the agreement.

7. Eligible Bidders:

Only the empaneled EPC contractors are eligible to participate in this tender. They will have to use the same registration carried out on CIL's e-Tender Portal (<https://coalindiatenders.nic.in>) during the empanelment process vide EOI.

(Empanelment notifications vide: (i) CIL/ Empanelment/EPC/Solar/2022/50, dated: 26.05.2022. (ii) CIL/Empanelment/EPC/Solar/2023/28, dated: 17.02.2023)

8. Eligibility Criteria:

- A. Working Capital:** The Bidder must submit the Certificate of possessing Minimum Working Capital of **Rs. 29.15 Crores** inclusive of access to lines of credit and availability of other financial resources to meet the requirement, issued by a Practicing Chartered Accountant having a Membership Number with Institute of Chartered Accountants of India. Such Certificate should contain the Unique Document Identification Number (UDIN). The bidder should possess the Working Capital issued within three months prior to the date of opening of tender.

In case, access to lines of credit constitutes the availability of Working Capital, Banker's Certificate (Scheduled Commercial Bank) shall also be submitted regarding availability of access to credit (issued within three months prior to the date of opening of tender) to meet the above eligibility criteria.

In respect of the above eligibility criteria the bidders are required to furnish the following information:

I. For CA Certificate:

- i. Amount of available working capital inclusive of access to lines of credit and availability of other financial resources.
- ii. Date on which the bidder possesses the required working capital.
- iii. Date of issue of Working Capital Certificate by CA.
- iv. Name of the Chartered Accountant (CA).
- v. Membership Number of CA who certifies the bidder's working capital.
- vi. UDIN no. of Working Capital Certificate issued by CA.

In case, access to lines of credit constitutes the availability of Working Capital, the bidders are also required to furnish the following information pertaining to Banker's Certificate (Scheduled Commercial Bank) regarding availability of access to credit (issued within three months prior to the date of opening of tender) .

II. For Banker's Certificate:

- i. Date of issue of certificate by bank.
- ii. Name of bank.
- iii. Address of the bank.
- iv. Value of access to credit issued by bank in the name of the bidder.

B. Permanent Account Number (PAN):

The bidder should possess Permanent Account Number(PAN) issued by Income Tax department, Govt. of India.

In respect of the above eligibility criteria the bidders are required to furnish the following information on-line:

- ✓ Confirmation regarding possessing of Permanent Account Number (PAN) issued by Income Tax department, Govt. of India in the form of Yes / No.
- ✓ Scanned copy of documents to be uploaded by bidder(s) in support of information / declaration furnished online by the bidder against Eligibility Criteria as Confirmatory Document.

C. Goods and Services Tax(Not Applicable for Exempted Services)

The bidder should be either GST Registered Bidder under regular scheme

OR

GST Registered Bidder under Composition Scheme

OR

GST unregistered Bidder

Note: If turnover of bidder exceeds exemption/threshold limit, the bidder must have GST Registration as per

GST Act and Rules.

Scanned copy of documents to be uploaded by bidder(s) in support of information/ declaration furnished online by the bidder against Eligibility Criteria as Confirmatory Document.

9. Submission of Bid:

- a. The bidders will have to accept unconditionally the online user portal agreement which contains the acceptance of all the Terms and Conditions of NIT including General and Special Terms & Conditions, Integrity Pact and other conditions, if any, along with on-line undertaking in support of the authenticity of the declarations regarding the facts, figures, information and documents furnished by the Bidder on-line in order to become an eligible bidder. No conditional bid shall be allowed/accepted.
- b. **Confirmatory Documents:** All the confirmatory documents as enlisted in the NIT in support of online/under annexures information submitted by the bidder are to be uploaded in Cover-I by the bidder while submitting his/her/their bid.

Sl. No.	Eligibility Criteria	Scanned copy of documents to be uploaded by bidder(s) in support of information/declaration furnished online/under annexures by the bidder against Eligibility Criteria (CONFIRMATORY DOCUMENTS)
1	2	3
1.	Availability of Working Capital (Ref. Clause No.8(A) of NIT)	<p>Certificate of possessing adequate Working Capital (with UDIN No.) issued by a Practicing Chartered Accountant having a membership number with Institute of Chartered Accountants of India to meet the eligibility criteria as per details mentioned in clause no. 8(A) and containing the information as furnished by bidder.</p> <p>In case, access to lines of credit constitutes the availability of Working Capital, Banker's Certificate (Scheduled Commercial Bank) shall also be submitted regarding availability of access to credit (issued within three months prior to the date of opening of tender) to meet the eligibility criteria as per details mentioned in clause no. 8(A) and containing the information as furnished by bidder.</p> <p>For foreign Partner(s), Banker's Certificate regarding availability of access to credit (issued within three months prior to the date of opening of tender) duly vetted/endorsed by the relevant Embassy/High Commission concerned, towards authenticity of document to meet the requirement of Working capital as per details mentioned in clause no. 8(A).</p>
2.	Permanent Account Number (Ref. Clause No.8(B) of NIT)	PAN card issued by Income Tax department, Govt. of India

3.	Goods and Services Tax (GST) Status of Bidder (Not Applicable for Exempted Services) (Ref. Clause No.8(C) of NIT and BOQ)	The following documents depending upon the status w.r.to GST as declared by Bidder in the BOQ sheet: a) Status: GST Registered Bidder under regular scheme Document: GST Registration Certificate (i.e. GST identification Number) issued by appropriate authority of India. b) Status: GST Registered Bidder under Composition Scheme Document: GST Registration Certificate (i.e. GST identification Number) issued by appropriate authority of India. c) Status: GST unregistered bidder Document: A Certificate from a practicing Chartered Accountant having membership number with Institute of Chartered Accountants of India certifying that the bidder is GST unregistered bidder in compliance with the relevant GST rules of India. Note: If turnover of bidder exceeds exemption/threshold limit, the bidder must have GST Registration as per GST Act and Rules.
4.	Legal Status of the bidder	<u>Document(s) covered under any one of the following sub-head(s):</u> 1. Affidavit or any other document to prove proprietorship/Individual status of the bidder. 2. Partnership deed containing name of partners. 3. Memorandum & Article of Association with certificate of incorporation containing name of bidder
5.	Digital Signature Certificate (DSC)	If the bidder himself is the DSC holder bidding on-line then no document is required. However, if the DSC holder is bidding online on behalf of the bidder then the Power of Attorney or any sort of legally acceptable document for the authority to bid on behalf of the bidder.
6.	Undertaking by Bidder/s on his Letter Head regarding genuineness of the information furnished by him on-line and authenticity of the scanned copy of documents uploaded by him on-line in support of his eligibility, and Bid Security Declaration as per the format given in the bid document at Appendix-14.	
7.	Written Consent regarding Arbitration Clause on his/her/their Letter Head as per Appendix-13. <u>Note:</u>	
	<ol style="list-style-type: none"> 1. In case of Proprietorship firm or Limited Company, this document is digitally signed by the DSC holder authorized by the bidder in case of Proprietorship or Director(s)/Managing Director of Limited Company in case of Limited Company. Hence, no physical signature is required. 2. In case of Partnership firm, this document is to be signed by all the Partners of the Partnership Firm. 3. In case of Project Affected Person(s) (PAPs) firms, this document is to be signed by all the partners of the PAPs who have formed Partnership firm and if the PAPs have formed co-operative society, this document is to be signed by any legally acceptable authorized signatory of the co-operative society, approved through the Resolution of the co-operative society. 	
8.	Letter of Bid by Bidder/s on his/her/their Letter Head as per Appendix-1.	

9.	Provision of Public Procurement (Preference to Make in India), Order 2017-Revision, dt. 16.09.2020	Declaration in compliance with the provisions of Public Procurement (Preference to Make in India), Order 2017-Revision vide order no. P-45021/2/2017/PP(BE-II)dtd 16.09.2020 of Ministry of Commerce and Industry, Government of India and amendments thereof: <ul style="list-style-type: none"> I. If the estimated value of Procurement is less than Rs. 10 crores, all the Bidders at the time of bidding shall submit either self-certification indicating the percentage of local content in the offered items. II. If the estimated value of procurement is more than Rs. 10 crores, all the Bidders shall submit along with its bid a certificate from the statutory auditor or cost auditor of the company (in case of companies) or from a practicing cost accountant or practicing chartered account (in respect of suppliers other than companies) giving the percentage of local content.
10.	Any other document to support the qualification information as submitted by bidder on-line.	

Note: Only one file in .pdf format can be uploaded against each eligibility criteria. Any additional/ other relevant documents to support the information/declaration furnished by bidder online against eligibility criteria may also be attached by the bidder in the same file to be uploaded against respective eligibility criteria.

c. **Letter of Bid (LoB):** The format of Letter of Bid (as given in the NIT) will be downloaded by the bidder and will be printed on Bidder's letter head and the scanned copy of the same will be uploaded during bid submission in cover-I. This will be the covering letter of the bidder for his submitted bid. The content of the "Letter of Bid" uploaded by the bidder must be the same as per the format downloaded from website and it should not contain any other information, which contradicts the content and spirit of the original format of LoB.

The Letter of bid will be digitally signed by DSC holder submitting bid online and it does not require any physical signature. However, if the Letter of Bid (LoB) bears the physical signature in addition to the digital signature of DSC holder, it will be accepted without questioning the identity of person signing the Letter of Bid.

If there is any change in the contents of Letter of Bid uploaded by bidder as compared to the format of Letter of Bid uploaded by the department with NIT document, then the LoB shall be requested under the head Confirmatory documents and subsequently accepted or rejected as applicable.

d. **Price bid:** The Price bid containing the Bill of Quantity will be in Excel format and will be downloaded by the bidder and bidder will quote the rates for all items on this Excel file. **Prior to quoting the rates in the BOQ file, the bidder will select the appropriate status from the following drop down list given in the BOQ:-**

1. GST Registered Bidder under regular scheme
2. GST Registered Bidder under Composition Scheme
3. GST unregistered Bidder

The rates quoted by the bidder will be including the GST as per the BOQ format. This file will be digitally signed and uploaded by the bidder after ascertaining the correctness of facts and figures.

Thereafter, the bidder will upload the same Excel file during bid submission in cover-II. The Price-bid will be in BOQ format and the bidder will have to mandatorily fill all the sections / sheets of the BOQ Excel. The Price Bid of the tenderers will have no condition. The price bid which is incomplete and not submitted as per instruction given in this document is liable for rejection.

Net Electrical Energy Generation Guarantee (NEEGG)

The Bidder shall be required to quote in the BOQ Excel file the year-wise Net Electrical Energy Generation Guarantee (NEEGG) for five (5) years period at the metering point. The Bidder shall give NEEGG per annum after considering proposed configuration and all local conditions, solar insolation, wind speed and direction, air temperature & relative humidity, barometric pressure, rainfall, sunshine duration, grid availability and grid related all other factors and losses due to near shading, incidence angle modifier, irradiance level, temperature loss, array loss, module quality loss, module array mismatch loss, soiling loss and various inverter losses etc.

Bidders are expected to undertake their own study of solar profile and other related parameters of the area and make sound commercial judgment about power output i.e. Net Electrical Energy Guaranteed Generation.

The Bids with NEEGG equivalent to less than **21.67 % CUF** at the Delivery Point for the first year shall be summarily rejected. The degradation in NEEGG quoted for any year shall not be more than 0.7% of that quoted for the previous year. If the Bidder anticipates any degradation of the modules during the first year, it shall be taken care of by the Bidder to provide additional capacity of solar PV modules to meet guaranteed generation at the end of first year to avoid liquidated damages/compensation on account of guaranteed generation.

In any Contract Year, if 'X' MWh of energy has been metered out at the Delivery Point for 'Y' MW Project capacity, $CUF = (X \text{ MWh} / (Y \text{ MW} * 8760)) * 100\%$;

System for decision of L1 bidder

The L1 bidder will be decided based on Evaluated Bid Value (EBV). Illustrative computation of EBV is shown in Appendix-5.

10. Bid Submission:

All bids are to be submitted on-line on the website <https://coalindiatenders.nic.in>. No bid shall be accepted off-line unless otherwise specified.

11. System Requirement:

It is the bidder's responsibility to comply with the system requirement i.e. hardware, software and internet connectivity at bidder's premises to access the e-tender website. Under any circumstances, CNUL shall not be liable to the bidders for any direct/indirect loss or damages incurred by them arising out of incorrect use of the e-tender system or internet connectivity failures.

12. Opening of Bid:

1. Tenders [Cover-I & OID (Technical-bid) and Cover-II (Price-bid)] will be decrypted and opened online by the Bid Openers with their Digital Signature Certificate (DSC) on the pre-scheduled date & time of tender opening.
2. The e-Procurement system will evaluate the Technical bids automatically on the basis of relevant data provided by the bidder while submitting the bid online. If the parameters furnished by bidder online in an objective and structured manner does not confirm to the required eligibility criteria as specified in the NIT, the bid will be automatically rejected by the system and the Price-bid of such bidders shall not be opened by the system.
3. After decryption and opening of bids, BOQ and all other documents uploaded by the eligible bidders will be opened and comparative statement of prices is generated by the system.

13. Evaluation of Tender:

1. Supportive documents of L-1 bidder only shall be downloaded for evaluation by the Tender Inviting Authority (TIA).
2. After evaluation of the uploaded documents, in case the Tender Committee finds that there is some deficiency in uploaded documents corresponding to the information furnished online/under appendices or in case corresponding document have not been uploaded by bidder(s) then the same will be specified online by Evaluator clearly indicating the omissions/shortcomings in the uploaded documents and indicating start

date and end date allowing **07 days (07 x 24 hours)** time for online re-submission by bidder(s). The bidder(s) will get this information on their personalized dash board under “Upload confirmatory document” link. Additionally, information shall also be sent by system generated email and SMS, but it will be the bidder’s responsibility to check the updated status/information on their personalized dash board regularly after opening of bid. No separate communication will be required in this regard. Non-receipt of e-mail and SMS will not be accepted as a reason of non-submission of documents within prescribed time. The bidder(s) will upload the scanned copy of all those specified documents in support of the information/declarations furnished by them online/under Annexures within the specified period of 07 days. If the bidder(s) fails to submit the specified document/s in 7(Seven) days (7 x 24 hours), no further document shall be sought from Bidder.

3. If the techno-commercial acceptability of L-1 bidder is established upon verification of uploaded documents and short fall documents if any, the case shall be considered by the tender committee. If the L-1 bidder happens to be defaulter upon verification, the documents of the next lowest bidder shall be downloaded for evaluation and short fall documents obtained if required. This process continues sequentially till techno-commercially acceptable L-1 is established.
4. It is responsibility of Bidders to upload legible/clearly readable scanned copy of all the required documents as mentioned in clause no. 9(b) titled- Confirmatory Documents.
5. The tender will be evaluated on the basis of documents uploaded by bidder(s) online. The bidder(s) is/are not required to submit hard copy of any document through offline mode. Any document submitted offline will not be given any cognizance in the evaluation of tender.
6. In case none of the bidder(s) complies the technical eligibility criteria as per NIT, then bidder(s) will be rejected online and re-tender (if required) will be done (with the same or different quantity, as per the instant requirement).
7. The Tender Committee will recommend for award of work to the successful bidder after evaluation of the reasonableness of L-1 rates.
8. If L1 bidder backs out (i.e. Techno commercially established L1 bidder), the bidder will be banned for two years from being eligible to submit bids in CIL and its subsidiaries.

14. Auto Extension of Critical Date

If number of bids received online is found to be less than 03 (three) on end date of bid submission then the following critical dates of the Tender will be automatically extended for a period of 04 (four) days of the following dates-

- Last date of submission of Bid.
- Date of Opening of Tender.

If any of the above extended Dates falls on Holiday i.e. a non-working day as defined in the e- Procurement Portal then the same is to be rescheduled to the next working day.

Notes: The validity period of tender shall be decided based on the final end date of submission of bids.

15.1 Each Bidder shall submit only one Bid, either individually, or as a proprietor, or as a partner in a partnership firm or as a Company registered under Companies Act. A Bidder who submits or participates in more than one Bid (other than as a sub-contractor or in cases of alternatives that have been permitted or requested) will cause all the proposals with the Bidder’s participation to be disqualified

15.2 Conflict of Interest:

A Bidder may be considered to have a Conflict of Interest with one or more parties in this bidding process,

if :

- a) They have controlling partner(s) in common; or
- b) They receive or have received any direct or indirect subsidy/financial stake from any of them; or

- c) They have the same legal representative/agent for purposes of this bid; or
- d) They have relationship with each other, directly or through common third parties, that puts them in a position to have access to information about or influence on the bid of another Bidder; or
- e) A Bidder or any of its affiliate participated as a consultant in the preparation of the design or technical specification of the contract that is the subject of the bid; or
- f) In case of a holding company having more than one Subsidiary/Sister Concern having common business ownership/management only one of them can bid. Bidders must proactively declare such sister/common business/management in same/similar line of Business;

All such Bidders having a Conflict of interest, shall be disqualified.

16. Location & Site Visit:

- a) The site locations are as follows:

Description of the location	Dughdha Washery
Nearest Urban Area	Bokaro (11 kM)
Nearest Highway	NH- 18 (11 kM)
Nearest Railway Station	Bokaro Steel City (20 kM)
Nearest Airport	Ranchi (118 kM) Durgapur (143 kM)

The bidder, at the Bidder’s own responsibilities, cost and risk, is encouraged to visit and examine the Site of Works and its surrounding, approach road, soil condition, investigation report, existing works, if any, connected to the tendered work, drawings connected to the work, if / as available and obtain all information that may be necessary for preparing the Bid and entering into a contract for execution of the works. The cost of visiting the Site shall be at the Bidder’s own expense.

- a) It shall be deemed that the Bidder has visited the Site/Area and got fully acquainted with the working conditions and other prevalent conditions and fluctuations thereto whether he/she/they actually visits the Site /Area or not and has taken all the factors into account while quoting his/her/their rates.
- b) The Bidder is expected, before quoting his rate, to go through the requirement of materials/workmanship, specification, requirements and conditions of contract.
- c) The Bidder, in preparing the bid, shall rely on the site investigation report referred to in the bid document (if available), supplemented by any information available to the Bidder.

17. Taxes and Duties:

All duties, taxes [excluding Goods and Services Tax (GST) and GST Compensation Cess, if applicable only] and other levies, royalty, building and construction workers cess (as applicable in States) payable by the bidder/contractor under the contract, or for any other cause as applicable on the last date of submission of bid, shall be included in the rates, prices and the total bid price submitted by the bidder. Applicable GST either payable by bidder or by company under reverse charge mechanism shall also be furnished by the Bidder in the BOQ sheet.

All investments, operating expenses, incidentals, overheads, leads, lifts, carriages, tools and plants etc. as may be attendant upon execution and completion of works shall also be included in the rates, prices and total Bid price submitted by the bidder.

However, such duties, taxes, levies etc. which is notified after the last date of submission of Bid and/or any increase over the rate existing on the last date of submission of Bid shall be reimbursed by the company on production of documentary evidence in support of payment actually made to the concerned authorities.

Similarly, if there is any decrease in such duties, taxes and levies the same shall become recoverable from the contractor. The details of such duties, taxes and other levies along with rates shall be declared by the bidder.

The item wise rate quoted by bidder shall be inclusive of all taxes, duties & levies and duly mentioning the specific GST & GST Compensation Cess, as applicable as per the BOQ format. The payment of GST and GST Compensation Cess by service availer (i.e. BCCL) to bidder/contractor (if GST payable by bidder/contractor) would be made only on the latter submitting a Bill/invoice in accordance with the provision of relevant GST Act and the rules made thereunder and after online filing of valid return on GST portal. Payment of GST & GST Compensation Cess is responsibility of contractor.

However, in case contractor is GST unregistered bidder/dealer in compliance with GST rules, the bidder/dealer shall not charge any GST and/or GST Compensation Cess on the bill/invoice. In such case, applicable GST will be deposited by BCCL directly to concerned authorities.

Input tax credit is to be availed by BCCL as per rule.

If BCCL fails to claim Input Tax Credit (ITC) on eligible Inputs and Capital Goods or the ITC claimed is disallowed due to failure on the part of supplier/vendor of goods and services in incorporating the tax invoice issued to BCCL in its relevant returns under GST, payment of CGST & SGST or IGST, GST (Compensation to State) Cess shown in tax invoice to the tax authorities, issue of proper tax invoice or any other reason whatsoever, the applicable taxes & cess paid based on such Tax invoice shall be recovered from the current bills or any other dues of the supplier/vendor along with interest, if any.

The rates and prices quoted by the Bidder shall be fixed for the duration of the contract and shall not be subject to variations on any account except to the extent variations allowed as per the conditions of the contract of the bidding document.

The company reserves the right to deduct/ withhold any amount towards taxes, levies, etc. and to deal with such amount in terms of the provisions of the Statute or in terms of the direction of any statutory authority and the company shall only provide with certificate towards such deduction and shall not be responsible for any reason whatsoever.

18. Cost of Bidding:

The bidder shall bear all costs associated with the preparation and submission of his bid and the Employer will in no case be responsible or liable for those costs.

19. Technical Specifications:

The tenderer shall closely study all specifications in detail, which govern the rates for which he is tendering. The provisions as contained in the O.M. dated 10.03.2021 issued by MNRE on the subject "Approved Models and Manufacturers of Solar Photovoltaic Modules (Requirement of Compulsory Registration) Order, 2019-Implementation-Reg." and its subsequent amendments and clarifications (including MNRE's clarification ref. no. F. No. 283/54/2018- GRID SOLAR-Part (1) dated 11.05.2021) shall be applicable for this Tender.

20. Currencies of Bid and Payment :

The unit rates and prices shall be quoted by the Bidder entirely in Indian Rupees only.

21. Commencement of Work or Zero Date:

The date of commencement or Zero Date shall be reckoned from the expiry of 30 days from the issue of letter of acceptance.

22. Handing Over of Site after completion of work:

On completion of the work all rubbish, debris, brick bats etc. shall be removed by the contractor(s) at his/their own expense and the site cleaned and handed over to the company and he/they shall intimate officially of having completed the work as per contract. The process of handing over will take place as provided in Section-6 Special Conditions of Contract of this tender document.

23. Deployment of Manpower and Machineries:

The tenderer(s) will deploy sufficient number and size of equipment / machineries/vehicles and the technical/supervisory personnel required for execution of the work.

24. Change in Constitution of the Contracting Agency :

Prior approval in writing of the company shall be obtained before any change is made in the constitution of the contracting agency, otherwise it will be treated as a breach of Contract.

25. Canvassing in Tender:

Canvassing in connection with the tenders in any shape or form is strictly prohibited and tenders submitted by such tenderers who resort to canvassing shall be liable for rejection.

26. Letter of Acceptance (LOA)/Work Order/Agreement:

The Bidder, whose Bid has been accepted, will be notified the award of contract on-line on the e-procurement portal on his personalized dash-board prior to expiration of the bid validity period. On issuance of Letter for Acceptance (LOA)/Work Order of the tender issued by the Company, Performance Security Deposit (PSD) must be submitted by the contractor within 21 days of issuance of work order/LOA, failing which the award of work shall be cancelled and the Bidder will be banned for 02(Two) years from being eligible to submit Bids in CIL and its subsidiaries. In case of Partnership firm, the banning shall also be applicable to all individual partners of Partnership firm.

On receipt of Letter for Acceptance (LOA)/Work Order of the tender issued by the Company, the successful tenderer shall execute contract agreement in the company's prescribed form for the due fulfillment of the contract. Failure to enter into the required contract within the specified period in the LOA/work order shall entail cancellation of LOA/work order and the Bidder will be banned for 02(Two) years from being eligible to submit Bids in CIL and its subsidiaries. The written contract to be entered into between the contractor and the company, shall be the foundation of the rights of both the parties and the contract shall not be deemed to be executed until the contract is signed by both the parties i.e. Contractor and the Company.

27. Bid Validity:

The validity period of the tenders shall be **120 (One Hundred Twenty)** days from the end date of bid submission.

In exceptional circumstances, prior to expiry of the original time limit, the Employer may request the bidders to extend the period of validity for a specified additional period. The employer's request and the bidder's responses shall be made in writing or by e-mail. A bidder may refuse the request. In case the Bidder refuses the request to extend the period of validity then no banning/ any penal action will be taken against the Bidder. A bidder agreeing to the request will not be required or permitted to modify his bid.

The tenderer shall not, during the said period or within the period extended by mutual consent, revoke or cancel his tender or alter the tender or any terms/conditions thereof without consent in writing of the company. In case the tenderer violates to abide by this, the Company will be entitled to take action as per clause No.28 (Modification and Withdrawal of Bid) of NIT.

28. Modification and Withdrawal of Bid :

Modification of the submitted bid shall be allowed on-line only before the deadline of submission of tender and the bidder may modify and resubmit the bid on-line as many times as he may wish.

Bidders may withdraw their bids online within the end date of bid submission. However, if the bidder once

withdraws his bid, he will not be able to resubmit the bid in this particular tender. For withdrawal of bid after the end date of bid submission, the bidder will have to make a request in writing to the Tender Inviting Authority.

28.1 Standard Operating Procedure for Withdrawal of Bid:

The system of on-line withdrawal is available on the e-procurement portal up to end date of bid submission, where any bidder can withdraw his/her bid which will attract no penal action from Tender Inviting Authority (TIA) of concerned department.

28.2 Acceptance of Withdrawal:

- (i) In case of withdrawal of bid by any bidder after end date of submission of bid a letter shall be sent by registered post/speed post in the address as available on the portal allowing 10 (ten) days' time and seeking confirmation from the bidder regarding the request for withdrawal of bid. The bidder has to confirm the withdrawal by sending a confirmation letter by Regd. Post/Speed post addressed to the Tender Inviting Authority. In case of non-receipt of any confirmation from the Bidder regarding withdrawal within stipulated period, the request for withdrawal will be ignored and Tender evaluation process will continue as usual.
- (ii) However if the concerned Bidder is a Partnership firm and if any of the partner wants to dissociate from the Bidding firm, then this would also tantamount to withdrawal of bid and above process of seeking confirmation will be followed by CNUL. If the Bidding firm want to deny the dissociation of any of the partner then a legally acceptable document in support of their claim duly signed by all the partners of the bidding firm should be sent by Regd Post/Speed Post to Tender Inviting Authority. In case of non-receipt of any such confirmation within stipulated period of **10(ten)** days, it will be construed that bidding firm has been dissolved and its bid will be treated as withdrawn.

Withdrawal of bid may be allowed till issue of work order/LOA with the following provision of penal action:

If the request of withdrawal is received after opening of bid, the bidder will be banned for two years from being eligible to submit bids in CIL and its subsidiaries.

- (a) If the bidder withdrawing his bid is other than L 1, the tender process shall go on.
- (b) If the bidder withdrawing his bid is L-1, then re-tender will be done.

Note: The penal action against clauses above will be enforced from the date of issue of such order.

- (iii) CNUL reserves the right to cancel the Tender if offer is withdrawn by any bidder after end date of submission apart from other penal actions as stipulated elsewhere in this document.

29. Restriction of bidder from a country which shares a land border with India

- I. Any bidder from a country which shares a land border with India will be eligible to bid in this tender only if the bidder is registered with the Competent Authority
- II. "Bidder" (including the term 'tenderer', 'consultant' or 'service provider' in certain contexts) means any person or firm or company, including any member of a consortium or Joint venture (that is an association of several persons, or firms or companies), every artificial juridical person not falling in any of the descriptions of bidders stated hereinbefore, including any agency branch or office controlled by such person, participating in a procurement process.
- III. "Bidder" from a country which shares a land border with India" for the purpose of this order means:-
 - a. An entity incorporated, established or registered in such a country; or
 - b. A subsidiary of an entity incorporated, established or registered in such a country; or
 - c. An entity substantially controlled through entities incorporated, established or registered in

- such a country; or
- d. An entity whose beneficial owner is situated in such a country; or
- e. An Indian(or other) agent of such an entity; or
- f. A natural person who is a citizen of such a country; or
- g. A consortium or joint venture where any member of the consortium or jointventure falls under any of the above.

IV. The beneficial owner for the purpose of (III) above will be as under:

1. In case of a company or Limited Liability Partnership, the beneficial owner is the natural person(s), who, whether acting alone or together, or through one or more juridical person, has a controlling ownership interest or who exercises control through other means.

Explanation-

- a. "Controlling ownership interest" means ownership of or entitlement to more than Twenty Five Percent of shares or capital or profits of the company.
 - b. "Control" shall include the right to appoint majority of the directors or to control the management or policy decisions including by virtue of their shareholding or management rights or shareholders agreements or voting agreements.
2. In case of a partnership firm, the beneficial owner is the natural person(s) who, whether acting alone or together, or through one or more juridical person, has ownership of entitlement to more than fifteen per cent of capital or profits of the ownership.
 3. In case of an unincorporated association or body of individuals, the beneficial owner is the natural person(s) who, whether acting alone or together, or through one or more juridical person, has ownership of entitlement to more than fifteen per cent of the property or capital or profits of such association or body of individuals.
 4. Where no natural person is identified under (1) or (2) or (3) above, the beneficial owner is the relevant natural person who holds the position of senior managing official.
 5. In case of a trust, the identification of beneficial owner(s) shall include identification of the author of the trust, the trustee, the beneficiaries with fifteen per cent or more interest in the trust and any other natural person exercising ultimate effective control over the trust through a chain of control or ownership.

V. An agent is a person employed to do any act for another or to represent another in dealings with third person.

VI. The successful bidder shall not be allowed to sub-contract works to any contractor from a country which shares a land border with India unless such contractor is registered with the competent Authority.

30. Postponement of scheduled date(s):

The Company reserves the right to postpone the date of receipt and opening of tenders or to cancel the tenders without assigning any reason whatsoever.

31. Refund of EMD:

- a) If EMD is paid by the bidder in online mode (Direct Debit/NEFT/RTGS) then the EMD of rejected bidders will be refunded at any stage directly to the account from where it had been received (except the cases where EMD is to be forfeited).
- b) No claim from the bidders will be entertained for non-receipt of the refund in any account other than the one from where the money is received.
- c) If the refund of EMD is not received by the bidder in the account from which the EMD has been made due to any technical reason then it will be paid through conventional system of e-payment. For this purpose, if required, Tender Inviting Authority will obtain the Mandate Form from the Bidder.

- d) In case the tender is cancelled then EMD of all the participating bidders will be refunded unless it is forfeited by the department.
- e) If the bidder withdraws his/her bid online (i.e. before the end date of submission of tender) then his/her EMD will be refunded automatically after the opening of tender.
- f) At the option of bidder, the EMD of successful bidder (on Award of Contract) will be retained by CIL/ Subsidiary and will be adjusted to Performance Security Deposit.

NOTE: The Earnest Money will not carry any interest. The unsuccessful bidder for this purpose means the bidders who have not qualified for opening of Price-bid and those who have not emerged as L-1 tenderer after opening of Price-bid.

32. Contract Agreement Document(s):

This Tender Notice shall be deemed to be part of the Contract Agreement. The “General Terms & Conditions”, Additional Terms & Conditions, Special Terms & Conditions (if any), Technical Specifications, drawings (if any) and any other document uploaded on portal as NIT document forms an integral part of this NIT and shall also form a part of the contract agreement.

However, bidders should note that in case of any contradiction or redundancy of clauses as mentioned in the “General Terms & Conditions of Contract” and “Special Conditions of Contract” or “Additional Terms & Conditions of Contract”, the clauses as mentioned in “Special Conditions of Contract” or “Additional Terms & Conditions of Contract” shall prevail. In these cases the clauses as mentioned in “Special Conditions of Contract” or “Additional Terms & Conditions of Contract” shall be considered.

33. Subletting of Work:

No subletting of work as a whole by the contractor is permissible. Permission is required for engagement of Sub-Contractor.

The contractor shall specify major items of supply or services for which he proposes to engage Subcontractor(s)/ Sub-Vendor (s) in its bid

Further, the installation/ usage of major equipment /product shall meet the following conditions:

1. Indigenously manufactured with BIS/ ISI marking wherever it is mandatory or conforming to BIS standards or ISO certification etc. or reputed brand in that order.
2. Overseas manufactured with certification regarding quality like relevant ISO/British Standard Certification / any other international quality certification etc. Failing which internationally reputed brand in that order.

The major items/ equipment/ products so specified by the bidder shall be incorporated in the Contract Document. The contractor may from time to time propose any addition or deletion from the list as mentioned in the contract document and will inform the Engineer in Charge/ Designated Officer in Charge with proper justification so as not to impede the progress of work. The same may be accepted by Engineer in Charge/ Designated Officer in Charge. However, such approval of the

Engineer-in Charge/ Designated Officer in Charge will not relieve the contractor from any of his obligation, duties and responsibilities under the contract.

Any addition of item(s) in the list shall also meet the conditions specified at 1 & 2 above.

- 34. Valid Electrical Contractor’s License issued by Electrical Licensing Board/Authority of any Indian State/UT, in accordance with IE rule. In case bidder possess valid Electrical Contractor’s license from any state other than Jharkhand as the case may be, the bidder shall also upload an undertaking to obtain and submit Electrical Contractor’s license from Jharkhand state before commencement**

of work, failing which the Work may not be awarded to the bidder.

35. Implementation of CMPF/EPF:

The tenderer shall have to ensure implementation of CMPF/EPF, if applicable, in respect of the workers deployed by him as detailed in the tender document.

36. Splitting up of the work:

The Company does not bind itself to accept the lowest tender and reserves the right to reject any or all the tenders without assigning any reasons whatsoever and to split up the work between two or more tenderer(s) or accept the tender in part and not in its entirety, at its sole discretion.

37. Settlement of Disputes:

Matters relating to any dispute or difference arising out of this tender and subsequent contract awarded based on this tender, shall be dealt as per Clause No. 42- title- 'Settlement of Disputes' of the 'General Terms and Conditions' of 'Conditions of Contract' of the tender document.

38. The laws applicable to this contract shall be the laws in force in India. The District Court where the subject work is executed or High Court of Jharkhand shall have exclusive jurisdiction in all matters arising under this contract.

39. If the bidder is a subsidiary of a company, the experience and resources of the holding company or its other subsidiaries will not be taken into account. However, if the bidder is a holding company, the experience and resources of its wholly owned subsidiaries will be taken into consideration.

40. Integrity Pact :

The bidders are requested to go through the integrity pact which is a part of the tender document. Following Independent External Monitor(s) are appointed for this tender, whose contact details are indicated as under:-

Name of IEM(s)	Ms.Nirmal Kaur, IPS (Retd.)	Shri Praveen Garg, IAS (Retd.)
Address	House no 8, Plot- 615, Road no- 17, Jawahar Nagar, Mango, Jamsedpur, Jharkhand, 832110	1/24, First Floor, Shanti Niketan, New Delhi-110021
E-mail & Contact Number	nirmalkaur1983@gmail.com Mobile- 9304795041	praveengargias@gmail.com Mobile – 9810517333

**Sd/-
GM (E&M)-SOLAR**

SECTION -2

GENERAL TERMS AND CONDITIONS OF CONTRACT

1.0 DEFINITIONS

- i.** The word "Company" or "Employer" or "Owner" or "BCCL" wherever occurs in the conditions, means the Bharat Coking Coal Limited, represented at the headquarters of the Company by the General Manager (E&M) or his authorized representative or any other officer specially deputed for the purpose.
- ii.** The word "Principal Employer" or "Engineer" wherever occurs, means the authorized representative or any other officer specially deputed by the Company for the purpose of contract.
- iii.** The word "Contractor"/"Contractors" or "Manufacturer" wherever occurs means the successful Bidder/Bidders who has/have been given written intimation about the acceptance of tender and shall include legal representative of such individual or persons composing a firm or a company or the successors and permitted assignees of such individual, firm or company, as the case may be.
- iv.** "The Site" shall mean the site of the contract work including land and any building and erections thereon and any other land allotted by the company for contractor's use in the performance of the contract.
- v.** The term "sub-contractor", as employed herein, includes those having a direct contract with contractor either on piece rate, items rate, time rate or on any other basis and it includes one who furnishes work to a special design according to the plans or specifications of this work but does not include one who merely supplied materials.
- vi.** "Consulting Engineer"/"Consultant" shall mean any firm or person duly appointed as such from time to time by the owner.
- vii.** 'Accepting authority' shall mean the management of the company and includes an authorised representative of the company or any other person or body of persons empowered in this behalf by the company.
- viii.** A 'Day' shall mean a day of 24 hours from midnight to midnight.
- ix.** Engineer-in-charge/Designated Officer-in-charge who is of an appropriate seniority will be responsible for supervising and administering the contract, certifying payment due to the contractor, valuing variations to the contract, awarding extension of time and valuing compensation events. Engineer-

- In-charge/Designated Officer-in-charge may further appoint his representatives i.e. another person/ Project Manager or any other competent person and notify to the contractor who is directly responsible for supervising the work being executed at the site, on his behalf under the Delegation of Powers of the company. However, overall responsibility, as far as the contract is concerned will be that of the Engineer-in-charge/Designated Officer-in-charge of CIL.
- x.** The 'contract' shall mean the notice inviting tender, the tender as accepted by the company and the formal agreement executed between the company and the contractor together with the documents referred to therein including conditions of contract, special conditions, if any, specifications, designs & drawings including those to be submitted during progress of work, scope of work, billing schedule/schedule of quantities with rates and amounts. Until the formal agreement is signed between the owner and Contractor, LOA/Work Order together with Contract Document, shall constitute the Contract.
- xi.** The 'works' shall mean and include the furnishing of equipment, labour, and the services in accordance with the contract or parts thereof as the case may be and shall also include all extra or additional, altered or substituted works or any work of emergent nature, which in the opinion of the Engineer-in-charge, become necessary during the progress of the works to obviate any risk or accident or failure or become necessary for security.
- xii.** "Specification" shall mean the technical specifications forming a part of the contract and such other schedules and drawings as may be mutually agreed upon.
- xiii.** 'Contract price' shall mean the total sum for which tender is accepted by the company.
- xiv.** 'Written notice' shall mean a notice or communication in writing and shall be deemed to have been duly served if delivered in person to the individual or to a member of the firm or to an office of the corporation/Company for whom it is intended, or if delivered at or sent by registered mail to the last business address known to him who gives the notice.
- xv.** "Letter of Acceptance" of the tender shall mean the official notice issued by the company notifying the contractor that his tender has been accepted.
- xvi.** "Date of Contract" shall mean the date on which both the parties have signed the contract agreement.
- xvii.** "Manufacturer's Works' or Contractor's Works" shall mean the place of work used by the Manufacturer, the Contractor, their collaborators or Sub-contractors for the performance of the works.
- xviii.** "Inspector" shall mean the Owner or any person nominated by the Owner from time to time, to inspect the equipment stores or Works under the contract and/or the duly authorized representative of the owner.
- xix.** When the words "Approved", "Subject to Approval", "Satisfactory", "Equal to", "Proper", "Requested", "As directed", "Where directed", "When directed", "Determined by", "Accepted", "Permitted", or words and phrases of like import are used, the approval, judgment, direction etc. is understood to be a function of the Owner/Engineer/Engineer-in-Charge.
- xx.** "Test of Completion" shall mean such tests as prescribed in the contract to be performed

by the contractor before the Works is taken over by the Owner.

- xxi.** "Start-up" shall mean the time period required to bring the equipment covered under the Contract from an inactive condition, when construction is essentially complete, to the state ready for trial operation. The start-up period shall include preliminary inspection and check out of equipment and supporting sub-systems; initial operation of the complete equipment covered under the Contract to obtain necessary pre-trial operation data, perform calibration and corrective action; shut down inspection and adjustment prior to the trial operation period.
- xxii.** "Initial operation" shall mean the first integral operation of the complete equipment covered under the contract with sub-systems and supporting equipment in service.
- xxiii.** "Trial Operation", "Reliability Test", "Trial Run", "Complete Test" shall mean the extended period of time after the "Start-up" period. During this trial operation period the unit shall be operated over the full load range. The length of Trial Operation shall be as determined by the Engineer, unless otherwise specified elsewhere in the Contract.
- xxiv.** "Performance and Guarantee Tests" shall mean all operation checks and tests required to determine and demonstrate capacity, efficiency, and operating characteristics as specified in the contract document.
- xxv.** "Commercial Operation" shall mean the condition of operation in which the complete equipment covered under the contract is officially declared by the owner to be available for continuous operation at different loads up to and including rated capacity. Such declaration by the owner however, shall not relieve or prejudice any of the contractor's obligation under this contract.
- xxvi.** "Final Acceptance" shall mean the owner's written acceptance of the works performed under the contract, after successful completion of performance and guarantee tests.
- xxvii** "Guarantee Period/Maintenance Period" shall mean the period during which the contractor shall remain liable for repair or replacement of any defective part of the works performed under the contract.
- xxviii** "Drawings"/"Plans" shall mean all :
 - (a)** drawings furnished by the owner/consultant as a basis for proposals,
 - (b)** supplementary drawings furnished by the Owner/Consultant to clarify and to define in greater detail the intent of the contract,
 - (c)** drawings submitted by the contractor with his proposal provided such drawings are acceptable to the Owner/Consultant,
 - (d)** drawings furnished by the Owner/Consultant to the Contractor during the progress of the work, and
 - (e)** engineering data and drawings submitted by the Contractor during the progress of the work provided such drawings are acceptable to the Engineer,
- xxix.** "Codes" shall mean the following, including the latest amendments, and/or replacements, if any:
 - (a)** Standards of Bureau of Indian Standards relevant to the works under the contract and their specifications.
 - (b)** Other Internationally approved Standards and/or rules and regulations touching the subject matter of the contract.
 - (i)** A.S.M.E. Test codes.

- (ii)** A.I.E.E. Test codes.
- (iii)** American Society of Materials Testing Codes.
- (iv)** Indian Electricity Act and Rules and Regulations made thereunder.
- (v)** Indian Explosive Act and Rules and Regulations made thereunder.
- (vi)** Indian Petroleum Act and Rules and Regulations made thereunder.
- (vii)** Indian Mines Act and Rules and Regulations made thereunder.

- (c) Any other laws, rules, regulations and Acts applicable in the country with respect to labour, safety, compensation, insurance etc.
- xxx. Words importing singular only shall also include the plural and vice-versa where the context so requires.
- xxxi. Words importing "Person" shall include firms, companies, corporations, and associations or bodies of individuals, whether incorporated or not.
- xxxii. Terms and expressions, not defined herein, shall have the same meaning as are assigned to them in the Indian Sale of Goods Act, failing that in the Indian Contract Act, and failing that in the General Clauses Act.
- xxxiii. "Commissioning" the plant/project shall mean completion in all respects of construction rendering the plant/project ready for performance test and commercial operation as per xxv.
- xxxiv. "Government Approvals" shall mean all permits, licenses, authorizations, consents, clearances, decrees, waivers, privileges, approvals from and filing with government instrumentalities necessary for the development, construction and operation of the plant/project.
- xxxv. "Month" shall mean a calendar month according to the Gregorian calendar.
- xxxvi. "Bank Guarantee" shall mean the Bank Guarantee to be provided by the Bidder in favour of '**Bharat Coking Coal Limited**' shall be operative in BCCL, Dhanbad.
- xxxvii. Bid/ offer/ proposal shall mean the proposal of the bidder submitted in response to the bid document issued by the company i.e. BCCL.

2.0 CONTRACT DOCUMENTS

The following documents shall constitute the contract documents: (i)

- Articles of Agreement,
- (ii) Notice Inviting Tender,
- (iii) Letter of Acceptance of Tender
- (iv) Conditions of contract, including general terms and conditions, additional terms and conditions, technical terms and conditions, erection terms and conditions, documents related to quality assurance, Integrity Pact, special conditions, if any etc. forming part of the Agreement,
- (v) Specifications, where it is part of Tender Documents,
- (vi) Performance Bank Guarantee as mentioned elsewhere in the NIT, e-mandate form duly filled and authenticated by bank,
- (vii) Scope of works/Bills of quantities/schedule of works/quantities,
- (viii) Contract Drawings/finalised work Program in the form of PERT Network along with Critical Path,
- (ix) Certificate of registration as per statutory requirements under Goods and Services Tax Registration, Contract Labour License, Electrical Contractor License etc. as may be applicable

- 2.1 After acceptance of tender the Contractor shall be deemed to have carefully examined all Contract Documents to his satisfaction. If he shall have any doubt as to the meaning of any portion of the Contract Documents, he shall before signing the Contract, set forth the

- particulars thereof, and submit them to the Owner in writing in order that such doubt may be removed. The Owner will provide such clarifications as may be necessary in writing to the Contractor. Any information otherwise obtained from the Owner or the Engineer shall not in any way relieve the Contractor of his responsibility to fulfill his obligations under the Contract.
- 2.2** The Contractor shall enter into a Contract Agreement with the Owner within 60(sixty) days from the date of issuance of LOA (Letter of Acceptance)' or within such extended time as may be granted by the owner. The performance BankGuarantee for the proper fulfillment of the contract shall be furnished by the contractor in the prescribed form within twenty one (21) days of issuance of LOA by the successful bidders. The performance Guarantee shall be as per terms prescribed in clause 3.0 of General Terms and Conditions of this tender.
- 2.3** The owner, after the issue of the letter of Acceptance of Tender, will send one copy of the final agreement to the contractor for his scrutiny and approval.
- 2.4** The Agreement, unless otherwise agreed to, shall be signed within 60 days from the date of issuance of LOA', at the office of the owner on a date and time to be mutually agreed. The contractor shall provide for signing of the contract, performance guarantee in copies as required, appropriate power of attorney and other requisite materials. In case it is agreed mutually that the contract is to be signed beyond the stipulated time, the bid guarantee submitted with the tender will have to be extended accordingly.
- 2.5** The agreement will be signed in six originals and the contractor shall be provided with one signed original and the rest will be retained by the owner. None of these documents shall be used by the contractor for any purpose other than this contract and the contractor shall ensure that all persons employed for this contract strictly adhere to this and maintain secrecy, as required of such documents.
- 2.6** The contractor shall provide free of cost to the owner all the engineering data, drawings and descriptive materials submitted with the bid, in at least six (6) copies to form a part of the contract immediately after issue of letter of acceptance.
- 2.7** Subsequent to signing of the contract, the contractor at his own cost shall provide the owner with at least six (6) true copies of agreement within thirty (30) days after the signing of the contract.
- 2.8** Clause left blank
- 2.9** The laws applicable to this contract shall be the laws in force in India. The Jharkhand High Court shall have exclusive jurisdiction in all matters arising under this contract.
- 3.0** **CONTRACT PERFORMANCE GUARANTEE/SECURITY DEPOSIT**
- 3.1** Security Deposit shall consist of two parts;
- a)** Performance Security to be submitted at award of work and
- b)** Retention Money to be recovered from running bills. The security deposit shall bear no interest.
- 3.1.1** Performance Security should be **5%** of contract amount and should be submitted by the successful bidder within 21 days of issue of LOA in the form of a Bank Guarantee as per the format specified in the Tender document from any scheduled bank acceptable to the owner. Bank guarantee issued by out station bank shall be operative at their local branch at Dhanbad. The BG

shall contain complete postal address, telephone number, fax number and email address of both out station bank issuing the BG as well as its local operating branch.

Performance Security Deposit (PSD) as Bank Guarantee, shall be in paper form on behalf of the Contractor in favor of "Bharat Coking Coal Limited." as well as issued under "Structured Financial Messaging System (SFMS)". Format and details for Bank Guarantee from a Schedule Bank shall be as provided at Appendix- 3 of the Tender.

Work shall commence only after submission of Performance Security.

In case the successful bidder fails to submit the Performance security within the stipulated time then the award of work shall be cancelled and the bidder will be banned for two years from being eligible to submit bids in CIL and its subsidiaries.

3.1.2 Clause left blank

3.1.3 Retention Money should be deducted at 5% from running bills. Total of performance security and Retention Money should not exceed 10% of contract amount or lesser sum indicated in the bid document.

Retention Money may be released against equivalent Bank Guarantee.

3.2 The Guarantee amount shall be payable to the Employer without any condition whatsoever.

3.3 Performance Security/Retention Money shall be converted into Performance Guarantee on successful completion of work in accordance with contract and upon satisfactory PG Test.

Performance security/ Retention Money /security deposit submitted in the form of BG which shall be valid for 90 days after the end date of scheduled completion and to be extended for minimum period of 1(One) year in one instance and must cover a time period of 90 days beyond completion of Defect Liability Period.

3.4 The Performance Guarantee shall cover additionally the following guarantees to the Employer:

- (a)** The successful bidder guarantees the successful and satisfactory operation of the equipment furnished and erected under the contract, as per the specifications and documents,
- (b)** The successful bidder further guarantees that the equipment provided and installed by him shall be free from all defects in design, material and workmanship and shall upon written notice from the employer fully remedy free of expenses to the Employer such defects as developed under the normal use of the said equipment within the period of guarantee specified in the relevant clause of the Conditions of Contract.

3.5 The Contract Performance Guarantee is intended to secure the performance of the entire Contract. However it is not construed as limiting the damages stipulated in the bidding documents.

3.6 All Bank Guarantees are to be submitted in the format prescribed by the company in bid document. Bank Guarantee shall be irrevocable and it shall be from any scheduled bank acceptable to the owner. The BG issued by outstation Bank shall be operative at its local branch at BCCL, Dhanbad.

3.7 The Company shall be at liberty to deduct/appropriate from the Contract Performance

Guarantee/Security Deposit such sums as are due and payable by the contractor to the company as may be determined in terms of the contract, and the amount appropriated from the Contract Performance Guarantee/Security Deposit shall have to be restored by Contractor subsequently.

- 3.8** Performance Security deposit and the balance SD i.e. Retention Money shall be returned to the Contractor after successful completion of O&M Period without any interest. Any defect/defects in the work, if detected during Defect Liability Period shall be rectified or equipment/ system shall be replaced at the cost of the Contractor and without any cost implication to the Company to the satisfaction of the Engineer-In-Charge within the said defect liability or its due extension till completion of the rectification/ replacement works as required.

4.0 ASSIGNMENT AND SUBLETTING OF CONTRACT

- 4.1** The contractor may, after informing the engineer in charge/ designated officer in charge, with proper justification for acceptance, assign or sub-let the contract or any part thereof other than for raw materials, for minor detail or any part of the plant for which makes are identified in the contract document. Suppliers of the equipment/system not identified in the contract document or any change in the identified supplier mentioned in the contract document can be changed and same may be informed to engineer in charge/ designated officer in charge, with proper justification for acceptance. The experience list of the equipment/system vendors under consideration by the contractor for this contract over the list mentioned in the contract document shall be furnished to the engineer in charge/ designated officer in charge prior to procurement of all such items/ equipment. Such assignment of subletting shall not relieve the contractor from any obligation, duty or responsibility under the contract. Any assignment as above without prior information of engineer shall be void.

- 4.2** For components/equipment procured by the contractors for the purposes of the contract, after obtaining the written approval of the owner, the contractor's purchase specifications and enquiries shall call for quality plans to be submitted by the suppliers along with their proposals. The quality plans called for from the vendors shall set out, during the various stages of manufacture and installation, the quality practices and procedures followed by the vendor's quality control organization, the relevant reference documents/standards used, acceptance level, inspection documentation raised, etc. Such quality plans of the successful vendor shall be discussed and finalized in consultation with the engineer and shall form a part of the purchase order/contract between the contractor and the vendor. Within 3 weeks of the release of the same purchase order/contracts for such bought out items/ components, a copy of the same without price details but together with detailed purchase specifications, quality plans and delivery conditions shall be furnished to the engineer by the contractor.

5.0 PATENT RIGHTS AND ROYALTIES

- 5.1** Royalties and fees for patent covering materials, articles, apparatus, devices, equipment or processes used in the works shall be deemed to have been included in the contract price. The contractor shall satisfy all demands that may be made at any time for such royalties or fees and he alone shall be liable for any damages or claims for patent infringements and shall keep the owner indemnified in that regard. The contractor shall, at his own cost and expense, defend all suits or proceedings that may be instituted for alleged infringement of any patent involved in the works, and, in case of an award of damages, the contractor shall pay for such award. In the event of any suit or other proceedings instituted against the

owner, the same shall be defended at the cost and expense of the contractor who shall also satisfy/comply and decree, order or award made against the owner. But it shall be understood that no such machine, plant, work, material or thing has been used by the owner for any purpose or any manner other than that for which they have been furnished and installed by the contractor and specified under these specifications. Final payment to the contractor by the owner will not be made while any such suit or claim remains unsettled. In the event any apparatus or equipment, or any matter thereof furnished by the contractor, is in such suit or proceedings held to constitute infringement, and its use is enjoined, the contractor shall at his option and at his own expense, either procure for the owner, the right to continue use of said apparatus, equipment or part thereof, replace it with non-infringing apparatus or equipment or modify it, so it becomes non-infringing.

6.0 TIME - THE ESSENCE OF CONTRACT

6.1 The date of commencement shall be reckoned from the expiry of 30 days from the issue of letter of acceptance. The PERT/BAR chart both for works as well as supply is to be mutually agreed and finalized within 30 days of issue of LOA.

6.2 The contractor shall submit a detailed PERT network within the time frame agreed above consisting of adequate number of activities covering various key phases of the works such as design, procurement, manufacturing, shipment and field erection activities within fifteen (15) days after the date of acceptance of LOA. This network shall also indicate the interface facilities to be provided by the owner and the dates by which such facilities are needed. Contractor shall discuss the network so submitted with the owner and the agreed network which may be in the form as submitted or in revised form in line with the outcome of discussions and shall form part of the contract to be signed. During the performance of contract, if in the opinion of the Engineer-in-charge proper progress is not maintained suitable changes shall be made in the contractor's operations to ensure proper progress.

6.3 The above PERT network shall be reviewed and periodic review reports shall be submitted by the contractor as directed by the engineer.

6.4 Subsequent to the award of the contract, the contractor shall make available to the engineer, a detailed manufacturing Program, in line with the agreed contract network. Such manufacturing Program shall be reviewed, updated and submitted to the Engineer, once every two months thereafter.

7.0 CONTRACT PRICE

7.1 The lump sum prices quoted by the contractor in his bid with additions and deletions as may be agreed before signing of the contract, for the entire scope of the work including furnishing and erection of equipment, transmission connectivity and ROW project commissioning, and operation and maintenance of the project for five (5) years from the COD of the project covered under the specifications and documents and shall be treated as the contract price.

8.0 CHANGED QUANTITY

- 8.1** The owner reserves the right to vary the quantities of items or groups of items to be ordered as specified in the accompanying technical specifications, as may be necessary, during the execution of the contract, but such variations unless otherwise specified in the accompanying technical specifications shall be limited to plus or minus twenty percent (20%) of the original quantity ordered.

9.0 DEDUCTIONS FROM CONTRACT PRICE

- 9.1** All costs, damages or expenses which the owner may have paid, for which under the contract the contractor is liable, will be claimed by the owner. All such claims shall be intimated in writing by the owner to the contractor regularly as and when they fall due. Such claims shall be supported by appropriate and certified vouchers or explanations, to enable the contractor to properly identify such claims. Such claims shall be paid by the contractor within fifteen (15) days of the receipt of the corresponding claims and if not paid by the contractor within the said period, the owner may then deduct the amount, from any moneys due or becoming due by him to the contractor under the contract or may be recovered by actions of law or otherwise, if the contractor fails to satisfy the owner of such claims and to recover the amount from any money due to the contractor on any account under any other contract including contracts awarded by Bharat Coking Coal Ltd or other subsidiaries of CIL and in the event of any shortfall, the contractor shall be called upon to pay the same on demand.

10.0 CONTRACT PRICE ADJUSTMENT

- 10.1** All adjustments in the contract price shall be computed in accordance with the conditions and formulae prescribed in the relevant clauses of 'Additional Terms and Conditions of Contract', the accompanying technical specifications and further satisfying the requirements specified herein.
- 10.2** The contract price stated in the contract agreement is the base price. A certain fixed percentage of the base price as indicated in the technical specifications shall not be subject to any price adjustment. The balance percentage viz. the cost portion shall only be subject to price adjustment.
- 10.3** Price adjustment shall be applicable to the cost portion, only if changes in the cost of labour and materials (either increases or decreases) occur during the contract period, directly affecting the cost portion.
- 10.4** Variations in the cost of materials shall be determined by comparing published material indices as on the last date of submission of bid (inclusive of price part) or the revised price bid, whichever is later, with the same indices published during the manufacture at the respective cut off periods for material as specified in clause 2.0 of Additional Terms and Conditions of Contract. Variations in the cost of labour shall be determined by comparing the wages as per the Minimum Wages Act of Central or state govt. (whichever is higher) as on the last date of submission of bid (inclusive of price part), or the revised price bid, whichever is later, with the same wages as per the Minimum Wages Act of Central or state govt. (whichever is higher), during the work/manufacture applicable to the place of work/manufacture at the respective cut off periods for labour as specified in clause 2.0 of Additional Terms and Conditions of Contract of this volume.

- 10.5** The total computed variation in the contract price shall be restricted to a limiting percentage as specified in clause 2.5 of Additional Terms and Conditions of Contract **of this volume.**
- 10.6** The price adjustment for the erection shall be made on the value of erection work done as indicated in each billing.
- 10.7** Every three months after the award of contract, and a month prior to shipment of equipment (in the case of ex-factory price component of contract price), and every month after establishing his site office (in the case of erection) the contractor shall submit to the engineer a written notice of the changes, if any, that have occurred in the specified material and labour indices during the previous reporting period containing the effective date of such change, the amount of change, the amount of contract price adjustment and documentary evidence to substantiate the price adjustment.
- 10.8** The contract price adjustment provisions detailed above, shall only be applicable if so specified in the Additional Terms and Conditions of Contract.

11.0 PACKING, FORWARDING AND SHIPMENT

- 11.1** The contractor, wherever applicable, shall after proper painting, pack and crate all equipment in such a manner as to protect them from deterioration and damage during rail and road transportation to the site and storage at the site till the time of erection. The contractor shall be held responsible for all damages due to improper packing.
- 11.2** The contractor shall notify the owner of the date of each shipment from his works, and the expected date of arrival at the site for the information of the owner.
- 11.3** The contractor shall also give all shipping information concerning the weight, size and content of each packing including any other information the owner may require.
- 11.4** The following documents shall be sent by registered post to the owner within 3 days from the date of shipment, to enable the owner to make progressive payments to the contractor. The payment shall be made only after receipt and acceptance of materials at site in good condition.

Application for payment in the standard format of the owner (3 copies) Invoice

	(6 copies)
Packing list	(6 copies)
Pre-despatch clearance certificate, if any	(3 copies)
Test certificate, wherever applicable	(3 copies)

- 11.5** The contractor shall prepare detailed packing list of all packages and containers, bundles and loose material forming each and every consignment despatched to site. The contractor shall further be responsible for making all necessary arrangements for loading, unloading and other handling right from his works up to the site and also till the equipment is erected, tested and commissioned. He shall be solely responsible for proper storage and safe custody of all equipment.

12.0 DEMURRAGE, WHARFAGE, ETC.

12.1 All demurrage, wharfage and other expenses incurred due to delayed clearance of the material or any other reason shall be to the account of the contractor.

13.0 INSURANCE

13.1 The contractor shall arrange, secure and maintain insurance as may be necessary and for all such amounts to protect his interests and the interests of the owner, against all risks as detailed herein in the joint names of the Owner and the Contractor with the condition that payments against all claims shall be payable by insurers to the owner as elaborated at clause

13.5. All premiums and other charges of the said insurance policies shall be paid by the contractor. The form and the limit of such insurance, as defined herein together with the under-writer thereof in each case shall be acceptable to the owner. However, irrespective of such acceptance, the responsibility to maintain adequate insurance coverage on comprehensive all risks basis at all time during the period of contract shall be that of the contractor alone. The contractor's failure in this regard shall not relieve him of any of his contractual responsibilities and obligations.

13.2 Any loss or damage to the equipment, during handling, transporting, storage and erection, till such time the plant is taken over by the owner, shall be to the account of the contractor. The contractor shall be responsible for preferring of all claims and make good for the damage or loss by way of repairs and/or replacement of the portion of the works damaged or lost. The transfer of title shall not in any way relieve the contractor of the above responsibilities during the period of the contract. The contractor shall provide the owner with a copy of all insurance policies and documents taken out by him in pursuance of the contract. Such copies of document shall be submitted to the owner immediately after such insurance coverage. The contractor shall also inform the owner in writing at least sixty (60) days in advance, regarding the expiry, cancellation and/or change in any of such documents and ensure revalidation/renewal, etc. as may be necessary well in time.

13.3 The risks that are to be covered under the insurance shall include, but not be limited to, the loss or damage in transit, storage at site, theft, pilferage, riot, civil commotion, weather conditions, accidents of all kinds, fire, etc. The scope of such insurance shall cover the entire value of the works from time to time.

13.4 All costs on account of insurance liabilities covered under the contract will be on contractor's account and will be included in contract price. However, the owner may from time to time, during the pendency of the contract, ask the contractor in writing to limit the insurance coverage risks and in such a case, the parties to the contract will agree for a mutual settlement for reduction in contract price to the extent of reduced premium amounts.

13.5 All insurance claims, payable by the insurers, shall be paid to the Owner which shall be released to the contractor in installments as may be certified by the Engineer-in-charge for the purpose of rebuilding or replacement or repair of the works and/or goods destroyed or damaged for which payment was received from the insurers.

13.6 The clause entitled insurance under the section erection terms and conditions of contract of this volume, covers the additional insurance requirements for the portion of the works to be performed at the site of work.

14.0 LIABILITY FOR ACCIDENTS AND DAMAGES

Under the contract, the contractor shall be responsible for loss or damage to the plant until the plant is taken over in accordance with clause entitled 'Taking Over' in section technical terms and conditions of contract of this volume.

15.0 LIQUIDATED DAMAGES FOR DELAY IN COMPLETION

15.1 If the contractor fails to maintain the required progress in terms of the agreedtime and progress chart or to complete the work and clear the site on or before the date of completion of contract or extended date of completion, he shall without prejudice to any other right or remedy available under the law to the company on account of such breach, pay as compensation/ Liquidated Damages @ half percent (1/2%) of the contract price per weekof delay. The aggregate of such compensation/ compensations shall not exceed 10 (ten) percent of the total value as shown in the contract.

This will also apply to items or group of items for which separate period of completion has been specified. The amount of compensation may be adjusted or set off against any sum payable to the contractor under this or any other contract with the company.

15.1.1 The company, if satisfied, that the works can be completed by the contractor within a reasonable time after the specified time of completion, may allow further extension of time at its discretion with or without the levy of L.D. In the event of extension granted being with L.D, the company will be entitled without prejudice to any other right or remedy available in that behalf, to recover from the contractor as agreed damages equivalentto half percent of the contract value of the works for each week or part ofthe week subject to a ceiling of 10% of the contract price.

15.1.2 The company, if not satisfied that the works can be completed by the contractor, and in the event of failure on the part of the contractor to complete work within further extension of time allowed as aforesaid, shall be entitled, without prejudice to any other right, or remedy available in that behalf, to rescind the contract.

15.1.3 The company, if not satisfied with the progress of the contract and in the event of failure of the contractor to recoup the delays in the mutually agreed time frame, shall be entitled to terminate the contract.

15.1.4 In the event of such termination of the contract as described in clauses 15.1.2 or 15.1.3 or both, the company, shall be entitled to recover L.D. up toten percent (10%) of the contract value besides recovery of compensation fordamage/loss for termination as provided in 20.6 of General terms andConditions of Contract.

15.2 The company may waive the payment of compensation, depending upon merit of the case, on request received from the contractor if the entire work is completed within the date as specified in the contract or as validly extended without stipulating any penalty.

16.0 CONTRACTOR'S DEFAULT

- 16.1** If the contractor shall neglect to execute the works with the diligence and expedition or shall refuse or neglect to comply with any reasonable orders given to him, in writing by the engineer in connection with the works or shall contravene the provisions of the contract, the owner may give notice in writing to the contractor to make good the failure, neglect or contravention complained of. Should the contractor fail to comply with the notice within thirty (30) days from the date of service thereof, then and in such case the owner shall be at liberty to employ other workmen and forthwith execute such part of the works as the contractor may have neglected to do or if the owner shall think fit, it shall be lawful for him, without prejudice to any other right he may have under the contract, to take the works wholly or in part thereof and in that event the owner shall have free use of all contractor's equipment that may have been at the time on the site in connection with the works without being responsible to the contractor for fair wear and tear thereof and to the exclusion of any right of the contractor over the same, and the owner shall be entitled to retain and apply any balance which may otherwise be due on the contract by him to the contractor, or such part thereof as may be necessary, the payment of the cost of executing the said part of the works or of completing the works as the case may be. If the cost of completing the works or executing a part thereof as aforesaid shall exceed the balance due to the contractor, the contractor shall pay such excess. Such payment of excess amount shall be independent of the liquidated damages for delay which the contractor shall have to pay if the completion of works is delayed.
- 16.2** In addition, such action by the owner as aforesaid shall not relieve the contractor of his liability to pay liquidated damages for delay in completion of works as defined in clause 15.0 of this section.
- 16.3** The termination of the contract under this clause shall not entitle the contractor to reduce the value of the performance bank guarantee nor the time thereof. The performance guarantee shall be valid for the full value and for the full period of the contract including guarantee period.
- 16.4** The bidding documents will clearly state that, if the contractor fails to complete the work and the order is cancelled, the amount due to him on account of work executed by him, if payable, shall be paid to him only after due recoveries as per the provisions of the contract and that too after alternative arrangements to complete the work has been made.

17.0 FORCE MAJEURE

- 17.1** Force majeure is herein defined as any cause which is beyond the control of the contractor or the owner as the case may be which they could not foresee or with a reasonable amount of diligence could not have foreseen and which substantially affect the performance of the contract, such as:
- (a)** Natural phenomena, including but not limited to floods, draughts, earthquakes and epidemics:
 - (b)** Acts of any government, including but not limited to war, declared or undeclared, priorities, quarantines, embargoes,

Provided either party shall within fifteen (15) days from the occurrence of such a cause notify the other in writing of such causes.

- 17.2** (a) The successful bidder / contractor will advise, in the event of his having resort to this clause by a registered letter duly certified by the local chamber of commerce or statutory authorities, the beginning and end of the cause of delay, within fifteen days of the occurrence and cessation of such Force Majeure condition. In the event of delay lasting over two months, if arising out of Force Majeure, the contract may be terminated at the discretion of the company.
- (b) For delays arising out of Force Majeure, the bidder/ contractor will not claim extension in completion date for a period exceeding the period of delay attributable to the causes of Force Majeure and neither company nor the bidder shall be liable to pay extra costs (like increase in rates, remobilization advance, idle charges for labour and machinery etc.) Provided it is mutually established that the Force Majeure conditions did actually exist.
- (c) If any of the Force Majeure conditions exists in the place of operation of the bidder even at the time of submission of bid he will categorically specify them in his bid and state whether they have been taken into consideration in their quotations.
- 17.3** The contractor or the owner shall not be liable for delays in performing his obligations resulting from any force majeure cause as referred to and/or defined above. The date of completion will, subject to hereinafter provided, be extended by a reasonable time even though such cause may occur after contractor's performance of his obligations has been delayed for other causes.

18.0 DELAYS BY OWNER OR HIS AUTHORISED AGENT

- 18.1** In case the contractor's performance is delayed due to any act of omission on the part of the owner or his authorized agents, then the contractor shall be given due extension of time for the completion of the works, to the extent such omission on the part of the owner has caused delay in the contractor's performance of his work. Regarding reasonableness or otherwise of the extension of time, the decision of the engineer shall be final.

19.0 EXTENSION OF DATE OF COMPLETION

- 19.1** On happening of any events causing delay as stated hereinafter, the contractor shall intimate immediately in writing the Engineer-in-charge:
- a.** due to any reasons defined as Force Majeure
 - b.** non-availability of stores which are the responsibility of the owner to supply
 - c.** non -availability or breakdown of tools and plant to be made available or made available by the owner
 - d.** delay on the part of the contractors or tradesmen engaged by the owner not forming part of the contract, holding up further progress of the work
 - e.** non-availability of working drawings/work program in time, which are to be made available by the company during progress of the work
 - f.** any other causes which, at the sole discretion of the company is beyond the control of the contractor
- 19.2** A "Hindrances Register" shall be maintained by both the Company and the Contractor at site to record the various hindrances, as mentioned above, encountered during the course of execution.
- 19.3** The contractor may request the company in writing for extension of time within 14 days of happening of such event causing delay stating also, if practicable, the period for which extension is desired. The company may, considering the eligibility of the request, give a fair

and reasonable extension of time for completion of the work. Such extension shall be communicated to the contractor in writing by the company through the Engineer-in-charge within 1 month of the date of receipt of such request. The contractor shall however use his best efforts to prevent or make good the delay by putting his endeavors constantly as may be reasonably required of him to the satisfaction of the Engineer-in-charge.

19.4 Provisional extension of time may also be granted by the Engineer-In-charge during the course of execution, on written request for extension of time within 15 (fifteen) days of happening of such events as stated above, reserving the company's right to impose/ waive liquidated damages at the time of granting final extension of time as per contract agreement.

19.5 When the period fixed for the completion of the contract is about to expire, the question of extension of the contract may be considered at the instance of the Contractor or the Company or the both. The extension will have to be by party's agreement, expressed or implied.

19.6 In case the Contractor does not apply for grant of extension of time within 15 (fifteen) days of hindrance occurring in execution of the work and the Company wants to continue with the work beyond the stipulated date of completion for reason of the work having been hindered, the Engineer-in-charge at his sole discretion can grant provisional extension of time even in the absence of application from the Contractor. Such extension of time granted by the Engineer-in-charge is valid provided the Contractor accepts the same either expressly or implied by his actions before and subsequent to the date of completion. Such extension of time shall be without prejudice to Company's right to levy compensation under the relevant clause of contract.

20.0 TERMINATION, SUSPENSION, CANCELLATION & FOR CLOSURE OF CONTRACT

20.1 The owner shall, in addition to other remedial steps to be taken as provided in the conditions of contract, be entitled to cancel the contract in full or in part, if the contractor

a. makes default in proceeding with the works with due diligence and continues to do so even after a notice in writing from the Engineer-in-charge, then on the expiry of the period as specified in the notice

or

b. commits default/breach in complying with any of the terms and conditions of the contract and does not remedy it or fails to take effective steps for the remedy to the satisfaction of the Engineer-in-charge, then on the expiry of the period as may be specified by the Engineer-in-charge in a notice in writing or

c. fails to complete the work or items of work with individual dates of completion, on or before the date/dates of completion or as extended by the company, then on the expiry of the period as may be specified by the Engineer-in-charge in a notice in writing

or

d. shall offer or give or agree to give any person in the service of the company or to any other person on his behalf any gift or consideration of any kind as an inducement or reward for act/acts of favour in relation to the obtaining or execution of this or any other contract for the company.

or

e. Shall try to obtain a contract with the company by way of ring tendering or other non-bona fide method of competitive tendering.

or

f. transfers, sublets, assigns the entire work or any portion thereof without the prior approval in writing from the Engineer-in-charge. The Engineer-in-charge may by giving a written notice, cancel the whole contract or portion of it in default.

20.2 The owner shall in such an event give fifteen (15) days notice in writing to the contractor of his decision to do so.

20.3 The contractor upon receipt of such notice shall discontinue the work on the date and to the extent specified in the notice, make all reasonable efforts to obtain cancellation of all orders and contracts to the extent they are related to the work terminated and terms satisfactory to the owner, stop all further sub-contracting or purchasing activity related to the work terminated, and assist the owner in maintenance, protection, and disposition of the works acquired under the contract by the owner.

20.4 The contract shall stand terminated under the following circumstances unless the owner is satisfied that the legal representatives of the individual contractor or of the proprietor of the proprietary concern and in the case of partnership the surviving partners, are capable of carrying out and completing the contract and the owner shall in any way not be liable to payment of any compensation to the estate of deceased contractor and/or to the surviving partners of the contractor's firm on account of the termination of the contract.:

a. If the contractor being an individual in the case of proprietary concern or in the case of a partnership firm any of its partners is declared insolvent under the provisions of insolvency act for the time being in force, or makes any conveyance or assignment of his effects or composition or arrangement for the benefit of his creditors amounting to proceedings for liquidation or composition under any insolvency act.

b. In the case of the contractor being a company, its affairs are under liquidation either by a resolution passed by the company or by an order of court, not being a voluntary liquidation proceedings for the purpose of amalgamation or reorganization, or a receiver or manager is appointed by the court on the application by the debenture holders of the company, if any.

c. If the contractor shall suffer an execution being levied on his/their goods, estates and allow it to be continued for a period of 21 days.

d. On the death of the contractor being a proprietary concern or of any of the partners in the case of a partnership concern and the company is not satisfied that the legal representative of the deceased proprietor or the other surviving partners of the partnership concern are capable of carrying out and completing the contract. The decision of the company in this respect shall be final and binding which is to be intimated in writing to the legal representative or to the partnership concern.

20.5 If the contractor is an individual or a proprietary concern and the individual or the proprietor dies and if the contractor is a partnership concern and one of the partners dies, then unless the owner is satisfied that the legal

representatives of the individual contractor or of the proprietor of the proprietary concern and in the case of partnership the surviving partners, are capable of carrying out and completing the contract the owner shall be entitled to cancel the contract as to its incomplete part without being in any way liable to payment of any compensation to the estate of deceased contractor and/or to the surviving partners of the contractor's firm on account of the cancellation of the contract.

The decision of the owner that the legal representatives of the deceased contractor or surviving partners of the contractor's firm cannot carry out and complete the contract shall be final and binding on the parties. In the event of such cancellation the owner shall not hold the estate of the deceased contractor and / or the surviving partners of the estate of the deceased contractor and / or the surviving partners of the contractor's firm liable to damages for not completing the contract.

20.6 On cancellation of the contract or on termination of the contract, the Engineer-in-charge shall have powers

- a. To take possession of the site and any materials, constructional plant, implements, stores, etc. thereon.
- b. In such an event, the contractor shall be liable for loss/damage suffered by the employer because of action under this clause and to compensate for this loss or damage, the employer shall be entitled to recover higher of the following:
 - i. Forfeiture of security deposit comprising of Performance Guarantee and Retention Money, at the disposal of the employer.
 - or
 - ii. 20% of value of incomplete work (Contract Value minus already executed value of the work).

The amount to be recovered from the contractor as determined above, shall, without prejudice to any other right or remedy available to the employer as per law or as per agreement, will be recovered from any money due to the contractor on any account or under any other contract and in the event of any shortfall, the contractor shall be liable to pay the same within 30 days. In case of failure to pay the same the amount shall be debt payable.

In the event of above course being adopted by the Engineer-in-charge, the contractor shall have no claim to compensation for any loss sustained by him by reasons of his having purchased materials, equipment or entered into agreement or made advances on any account or with a view to the execution of work or performance of the contract. And in case action is taken under any of provision aforesaid, the contractor shall not be entitled to recover or to be paid any sum for any work thereof or actually performed under this contract unless and until the engineer-in-charge has certified in writing the performance of such work and value payable in respect thereof and he shall only be entitled to be paid the value so certified.

The need for determination of the amount of recovery of any extra cost/expenditure or of any loss/damage suffered by the company shall not however arise in the case of termination of the contract for death/demise of the contractor.

20.7 Suspension of work - The company shall have power to suspend the progress of the work

or any part thereof and the Engineer-in-charge may direct the contractor in writing to suspend the work, for such period and in such manner as may be specified therein, on account of any default on the part of the contractor, or for proper execution of the work for reasons other than any default on the part of the contractor, or on ground of safety of the work or part thereof. In the event of suspension for reason other than any default on the part of the contractor, extension of time shall be allowed by the company equal to the period of such suspension. Any necessary and demonstrable costs incurred by the contractor as a result of such suspension of the works will be paid by the owner, provided such costs are substantiated to the satisfaction of the engineer. The owner shall not be responsible for any liabilities if suspension or delay is due to some default on the part of the contractor or his sub-contractor.

The work shall, throughout the stipulated period of contract, be carried out with all due diligence on the part of the contractor. In the event of termination or suspension of the contract, on account of default on the part of the contractor, as narrated hereinbefore, the security deposit and other dues of this work or any other work done under this company shall be forfeited and brought under the absolute disposal of the company provided, that the amount so forfeited shall not exceed 10% of the contract value.

20.8 For Closure of contract in full or in part - If at any time after acceptance of the tender, the company decides to abandon or reduce the scope of the work for any reason whatsoever the company, through its Engineer-in-charge, shall give notice in writing to that effect to the contractor. In the event of abandonment/reduction in the scope of work, the company shall be liable

- a. to pay the contractor at the contract rates full amount for works executed and measured at site upto the date of such abandonment/reduction in the work.
- b. to pay reasonable amount assessed and certified by the Engineer-in-charge of the expenditure incurred, if any, by the contractor on preliminary works at site. e.g. temporary access roads, temporary construction for labour and staff quarters, office accommodation, storage of materials, water storage tanks and supply for the work including supply to labour/staff quarters, office, etc.
- c. to pay for the materials brought to site or to be delivered at site, which the contractor is legally liable to pay, for the purpose of consumption in works carried out or were to be carried out but for the closure, including the cost of purchase and transportation and cost of delivery of such materials. The materials to be taken over by the company should be in good condition and the company may allow at its discretion the contractor to retain the materials in full or part if so desired by him and to be transported by the contractor from site to his place.
- d. to take back the materials issued by the company but remaining unused, if any, in the work on the date of abandonment/reduction in the work, at the original issued price less allowance for any deterioration or damage caused while in custody of the contractor
- e. to pay for the transportation of tools and plants of the contractor from site to contractor's place or to any other destination, whichever is less.

The contractor shall, if required by the Engineer-in-charge, furnish to him books of accounts, papers, relevant documents as may be necessary to enable the Engineer-in-charge to assess the amount payable in terms of para 20.8 (b), (c) and (e) above, the contractor shall not have

any claim for compensation whatsoever either for abandonment or for reduction in the scope of work, other than those as specified above.

21.0 NO WAIVER OF RIGHTS

Neither the inspection by the owner or the engineer or any of their officials, employees or agents nor any order by the owner or the engineer for payment of money or any payment for or acceptance of, the whole or any part of the works by the owner or the engineer, nor any extension of time, nor any possession taken by the engineer shall operate as a waiver of any provision of the contract, or of any power herein reserved to the owner, or any right to damages herein provided, nor shall any waiver of any breach in the contract be held to be a waiver of any other or subsequent breach.

22.0 CERTIFICATE NOT TO AFFECT RIGHT OF OWNER AND LIABILITY OF CONTRACTOR

No interim payment certificate of the engineer, nor any sum paid on account, by the owner, nor any extension of time for execution of the works granted by the engineer shall affect or prejudice the rights of the owner against the contractor or relieve the contractor of his obligations for the due performance of the contract, or be interpreted as approval of the works done or of the equipment furnished and no certificate shall create liability for the owner to pay for alterations, amendments, variations or additional works not ordered, in writing, by the engineer or discharge the liability of the contractor for the payment of damages whether due, ascertained, or certified or not, or any sum against the payment of which he is bound to indemnify the owner, nor shall any such certificate nor the acceptance by him of any sum paid on account or otherwise affect or prejudice the rights of the contractor against the owner.

23.0 GRAFTS AND COMMISSIONS ETC.

Any graft, commission, gift or advantage given, promised or offered by or on behalf of the contractor or his partner, agent, officers, director, employee or servant or any one of his or their behalf in relation to the obtaining or to the execution of this or any other contract with the owner, shall, in addition to any criminal liability which it may incur, subject the contractor to the cancellation of this and all other contracts and also to payment of any loss or damage to the owner resulting from any cancellation. The owner shall then be entitled to deduct the amount so payable from any moneys otherwise due to the contractor under the contract.

24.0 LANGUAGE AND MEASURES

All documents pertaining to the contract including specifications, schedules notices, correspondence, operating and maintenance instructions, drawings or any other writing shall be written in English language. The metric system of measurement shall be used exclusively in the contract.

25.0 RELEASE OF INFORMATION

The contractor shall not communicate or use in advertising, publicity, sales releases or in any other medium photographs or other reproduction of the works under this contract, or descriptions of the site, dimensions, quantity, quality or other information, concerning the works unless prior written permission has been obtained from the owner.

26.0 CONSTRUCTION OF THE CONTRACT

- 26.1** In case owner hands over his equipment to the contractor for executing, then the contractor shall at the time of taking delivery of the equipment/ dispatch documents be required to execute an indemnity bond in favour of the owner in the form acceptable to the owner for keeping the equipment in safe custody and to utilize the same exclusively for the purposes of the said contract.
- 26.2** The contract shall in all respects be construed and governed accordingly to Indian Laws.
- 26.3** It is clearly understood that the total consideration for the contract (s) has been broken up into various components only for the convenience of payment of advance under the contract (s) and for the measurement of deviations or modifications under the contract (s).

27.0 COMPLETION OF CONTRACT

Unless otherwise terminated under the provisions of any other relevant clause, this contract shall be deemed to have been completed at the expiration of the guarantee period as provided for under the clause entitled 'Guarantee' in this section.

28.0 ENFORCEMENT OF TERMS

The failure of either party to enforce at any time of the provisions of this contract or any rights in respect thereto or to exercise any option herein provided, shall in no way be construed to be a waiver of such provisions, rights or options or in any way to affect the validity of the contract. The exercise by either party of any of its rights herein shall not prejudice or prejudice either party from exercising the same or any other right it may have hereunder.

29.0 ENGINEER'S DECISION

- 29.1** In respect of all matters which are left to the decision of the engineer including the granting or withholding of the certificates, the engineer shall, if required to do so by the contractor give in writing a decision thereon.
- 29.2** If in the opinion of the contractor, a decision made by the engineer is not in accordance with the meaning and intent of the contract, the contractor may file with the engineer within fifteen (15) days after receipt of the decision, a written objection to the decision. Failure to file an objection within the allotted time will be considered as acceptance of the engineer's decision and the decision shall become final and binding.
- 29.3** The engineer's decision and the filing of the written objection thereto shall be a condition precedent to the right to any legal proceedings. It is the intent of the agreement that there shall be no delay in the execution of the works and the decision of the engineer as rendered shall be promptly observed.

30.0 CO-OPERATION WITH OTHER CONTRACTORS AND CONSULTING ENGINEERS

The contractor shall agree to co-operate with the owner's other contractors and consulting engineers and freely exchange with them such technical information as is necessary to obtain the most efficient and economical design and to avoid unnecessary duplication of efforts.

The engineer shall be provided with three copies of all correspondence addressed by the contractor to other sub -contractors and consulting engineers in respect of such exchange of technical information.

31.0 TRAINING OF OWNER'S PERSONNEL

31.1 The contractor shall undertake to train free of cost, engineering personnel selected and sent by the owner at the works of the contractor unless otherwise specified in the technical specifications. The period and the nature of training for the individual personnel (Executive as well as Staff / Technicians) shall be agreed upon mutually between the contractor and the owner or as specified in the NIT. These engineering personnel shall be given special training in the shops, where the equipment will be manufactured and/or their collaborator's works and where possible, in any other plant where equipment manufactured by the contractor or his collaborator is under installation or test, to enable those personnel to become familiar with the equipment being furnished by the contractor.

31.2 All traveling and living expenses for the engineering personnel to be trained during the total period of training will be borne by the owner. These engineering personnel while undergoing training shall be responsible to the contractor for discipline.

31.3 In the event of the owner, for any reason, failing to avail of the training facilities, he shall not be entitled for any rebate whatsoever on this account.

32.0 POWER TO VARY OR OMIT WORK

32.1 No alterations, amendments, omissions, suspensions or variations of the works (hereinafter referred to as 'Variation') under the contract as detailed in the contract documents, shall be made by the contractor except as directed in writing by the engineer, but the engineer shall have full power subject to the provision hereinafter contained from time to time during the execution of the contract, by notice in writing, to instruct the contractor to make such variation without prejudice to the contract. The contractor shall carry out such variation and be bound by the same conditions as far as applicable as though the said variation occurred in the contract documents. If any suggested variation would, in the opinion of the contractor, if carried out, prevent him from fulfilling any of his obligations or guarantees under the contract, he shall notify the engineer thereof in writing and the engineer shall decide forthwith, whether or not the same shall be carried out and if the engineer confirms his instructions, contractor's obligations and guarantees shall be modified to such an extent as may be mutually agreed. Any agreed difference in cost occasioned by any such variation shall be added to or deducted from the contract price as the case may be.

32.2 In the event of the engineer requiring any variation, such reasonable and proper notice shall be given to the contractor to enable him to work his arrangements accordingly, and in cases where goods or materials are already prepared or any design, drawings or pattern made or work done requires to be altered, a reasonable and agreed sum in respect thereof shall be paid to the contractor.

32.3 In any case in which the contractor has received instructions from the engineer as to the requirement of carrying out the altered or additional substituted work which either then or later on, will in the opinion of the contractor, involve a claim for additional payments, the contractor shall immediately and in no case later than thirty (30) days, after receipt of the instructions aforesaid and before carrying out the instructions, advise the engineer to that effect. But the engineer shall not become liable for the payment of any charges in respect of any such variations, unless the instructions for the performance of the same shall be

confirmed in writing by the engineer.

32.4 If any variation in the works, results in reduction of contract price, the parties shall, agree, in writing, so to the extent of any change in the price, before in contractor proceeds with the change.

32.5 In all the above cases, in the event of a disagreement as to the reasonableness of the said sum, the decision of the engineer shall prevail.

32.6 Notwithstanding anything stated above in this clause, the engineer shall have the full power to instruct the contractor, in writing, during the execution of the contract, to vary to quantities of the items or groups of items. The contractor shall carry out such variations and be bound by the same conditions, as though the said variations occurred in the contract documents. However, the contract price shall be adjusted at the rates and the prices provided for the original quantities in the contract.

33.0 GUARANTEE/DEFECT LIABILITY

33.1 As per Special Conditions of Contract provided in the Tender Document

34.0 REPLACEMENT OF DEFECTIVE PARTS AND MATERIALS

34.1 As per Special Conditions of Contract provided in the Tender Document

35.0 DEFENCE OF SUITS

If any action in court is brought against the owner or engineer or an officer or agent of the owner, for the failure or neglect on the part of the contractor to perform any acts, matters, covenants or things under the contract, or for damage or injury caused by the alleged omission or negligence on the part of the contractor, his agents, representatives or his sub-contractors, workmen, suppliers or employees, the contractor shall in all such cases Indemnify and keep the owner, and the engineer and/or his representative, harmless from all losses, damages, expenses or decrees arising of such action.

36.0 LIMITATIONS OF LIABILITIES

Except in case of Criminal Negligence or Willful Misconduct,

(i) Notwithstanding anything herein to the contrary, no party shall be liable for any indirect, special, punitive, consequential or exemplary damages, whether foreseeable or not, arising out of or in relation to this contract, loss of goodwill or profits, lost business however characterized, any/or from any other remote cause whatsoever.

(ii) The Contractor shall not be liable to the owner for any losses, claims, damages, costs or expenses whatsoever arising out of or in connection with this contract in excess of the contract value of the work which caused such losses, claims, damages, costs or expenses.

(iii) However, the limitation of liability of the contractor indicated above shall not apply to liquidated damages.

37.0 MARGINAL NOTES

The marginal notes to any clause of the contract shall not affect or control the construction of such clause.

38.0 TAXES, PERMITS & LICENCES

- 38.1** The contractor shall be liable and pay all- Indian taxes, (other than Goods and Services tax and GST Compensation Cess, if applicable) duties, levies, royalties, whether local, municipal, provincial or central lawfully assessed against the owner or the contractor in pursuance of the contract. In addition, the contractor shall be responsible for payment of all Indian duties, levies and taxes lawfully assessed against the contractor for his personal income and property only. This clause shall be read in conjunction with clause 17 of e-tender notice.

The contractor, along with his bills, shall submit proper documents in the name of the Company to enable the Company to claim Input Tax Credit under the applicable laws. The invoice shall be in compliance with the relevant rules.

BCCL is entitled to avail Input Tax Credit on account of: CGST, SGST/UTGST, IGST and GST Compensation Cess, as applicable for indigenous product/imported products. Hence set off allowed against CGST, SGST/UTGST, IGST and GST Compensation Cess as per relevant rules/act. Contractor shall submit relevant document as desired by BCCL at the time of supply, along with the bills/invoice as per relevant rules for enabling BCCL to claim Input tax credit benefit.

- 38.2** The Company shall deduct Income Tax as per prevalent rate from time to time from the gross amount (excluding GST) of the bill payable to the contractor; at present the rate of deduction is 1% for individual/proprietorship firm and 2% for others. However, if the contractor produces a certificate from the Income Tax authorities for no deduction of tax / deduction of tax at reduced rate, the same shall be complied with by the Company.

39.0 PROGRESS REPORTS AND PHOTOGRAPHS

During the various stages of the works in the pursuance of the contract, the contractor shall at his own cost submit periodic progress reports as maybe reasonably required by the engineer with such materials as charts, net-works, photographs, test certificates, etc. such progress report shall be in the form and size as may be required by the engineer and shall be submitted in at least three (3) copies.

40.0 LONG TERM AVAILABILITY OF SPARES

- 40.1** The contractor shall guarantee the long term availability of spares to the owner for the tenure of the Contract.
- 40.2** The contractor will indicate in advance the delivery period of the items of spares, which the owner may procure at its own discretion. In case of emergency requirements of spares, the contractor would make every effort to expedite the manufacture and delivery of such spares on the basis of mutually agreed time schedule.
- 40.3** The above procedure shall apply for future procurement of items included in standby spare list, mandatory spares lists, optional spares list and special tools, plants and equipment list, if any, specified in the bid documents.

40.4 The Contractor shall indemnify the owner for the availability of long time spares as per the terms and conditions laid down above in clause 40.1 to clause 40.3.

40.5 The Clauses 40.1 to 40.4 shall be read in conjunction with the section on Mandatory Spares as provided in the Technical Specifications.

41.0 PAYMENT

41.1 The payment to the contractor for the performance of the works under the contract will be made by the owner as per the guidelines and conditions specified herein and in the relevant clauses in Section-6 Special Conditions of Contract of this tender. All payment made during the contract shall be on account payments only. The final payment will be made on completion of all the works and on fulfillment by the contractor of all his liabilities under the contract. The paying authority will be GM (Finance), BCCL or his authorized representatives.

The payment to the contractor will be made through Electronics Mode.

41.2 CURRENCY OF PAYMENT

All payments under the contract shall be in Indian Rupees only.

41.3 DUE DATES FOR PAYMENT

Owner will make progressive payment as and when the payment is due as per the terms of payment set forth in the accompanying technical specifications. Payment will become due and payable by the owner within thirty (30) days from the date of receipt of contractor's bill/invoice/debit note by the owner, provided the documents submitted are complete in all respects.

41.4 PAYMENT SCHEDULE

The contractor shall prepare and submit to the engineer for approval, a break-up of the contract price. This contract price break-up shall be interlinked with the agreed detailed PERT network of the contractor setting forth his starting and completion dates for the various key phases of works prepared as per condition of this section. While preparing the PERT network, the supply of P&M Equipment shall be linked to construction of respective Civil and Structural Works. Any payment under the contract shall be made only after the contractor's price break-up is approved by the engineer. The aggregate sum of the contractor's price break-up shall be equal to the lump sum contract price. The detailed payment schedule is provided in relevant clauses in Section-6 Special Conditions of Contract of this tender.

41.5 INTERIM PAYMENT

41.5.1 The contractor shall submit running bill for the payment in the prescribed proforma of the owner to be supplied in due course at the time of Payment.

41.5.2 Each such running bill shall state the amount claimed and shall set forth in detail, in the order of the payment schedule, particulars of the works including the works executed at site and of the equipment brought on to the site pursuant to the contract up to the date mentioned in the bill and for the period covered since the last preceding certificate, if any.

41.5.3 Every interim payment claim shall indicate the contract value of the works executed up to the date mentioned in the running bill, provided that no sum shall be included in any running bill in respect of the works that, according to the decision of the engineer, does not comply with the contract, or has been performed, at the date of certificate prematurely.

41.6 TERMS OF PAYMENTS

41.6.1 Payment Schedule shall be as per Special Conditions of Contract. Since the total job is on turn-key basis, any payment to the Contractor before the final payment shall be treated as provisional payment towards the total contract value.

The Contractor may at intervals of not less than one month submit claims/ bills for payment on account of work done after proper scrutiny and certification of the same by the Employer.

All such payments shall be made by the Employer online within a month from the date of the submission of claims/bills. Payment will also be governed by the General Terms & Conditions of Contract. Any sum due from the Contractor shall be deducted from the first or next subsequent on account of payments as the case may be.

42.0 SETTLEMENT OF DISPUTES

It is incumbent upon the contractor to avoid litigation and disputes during the course of execution. However, if such disputes take place between the contractor and the department, effort shall be made first to settle the disputes at the company level.

The contractor should make request in writing to the Engineer-in-charge for settlement of such disputes/claims within 30 (thirty) days of arising of the cause of dispute/ claim failing which no disputes/ claims of the contractor shall be entertained by the company.

Effort shall be made to resolve the dispute in two stages.

In first stage dispute shall be referred to Dealing Department of CIL. If difference still persist the dispute shall be referred to a committee constituted by the owner. The committee shall have one member of the rank of Director of the company who shall be chairman of the committee.

If differences still persist, the settlement of the dispute shall be resolved in the following manner:

Disputes relating to the commercial contracts with Central Public Sector Enterprises/ Govt. Departments (except Railways, Income Tax, Customs & excise duties)/ State Public Sector Enterprises shall be referred by either party for Arbitration to the PMA (Permanent Machinery of Arbitration) in the department of Public Enterprises.

In case of parties other than Govt. Agencies, the redressal of the dispute may be sought through Arbitration (THE ARBITRATION AND CONCILIATION ACT, 1996 as amended by AMENDMENT ACT of 2015, and further amendments, if any).

42A. Settlement of Disputes through Arbitration

If the parties fail to resolve the disputes/ differences by in house mechanism, then, depending on the position of the case, either the employer/owner or the contractor shall give notice to

other party to refer the matter to arbitration instead of directly approaching Court. The contractor shall, however, be entitled to invoke arbitration clause only after exhausting the remedy available under the clause 42.

In case of parties other than Govt. agencies, the redressal of disputes/ differences shall be sought through Sole Arbitration as under.

Sole Arbitration:

In the event of any question, dispute or difference arising under these terms & conditions or any condition contained in this contract or interpretation of the terms of, or in connection with this Contract (except as to any matter the decision of which is specially provided for by these conditions), the same shall be referred to the sole arbitration of a person, appointed to be the arbitrator by the Competent Authority of CIL / CMD of Subsidiary Company (as the case may be). The award of the arbitrator shall be final and binding on the parties of this Contract.

(a) In the event of the Arbitrator dying, neglecting or refusing to act or resigning or being unable to act for any reason, or his/her award being set aside by the court for any reason, it shall be lawful for the Competent Authority of CIL / CMD of Subsidiary Company (as the case may be) to appoint another arbitrator in place of the outgoing arbitrator in the manner aforesaid.

(b) It is further a term of this contract that no person other than the person appointed by the Competent Authority of CIL / CMD of Subsidiary Company (as the case may be) as aforesaid should act as arbitrator and that, if for any reason that is not possible, the matter is not to be referred to Arbitration at all.

Subject as aforesaid, Arbitration and Conciliation Act, 1996 as amended by Amendment Act of 2015 or further amendments, if any, and the rules thereunder and any statutory modification thereof for the time being in force shall be deemed to apply to the Arbitration proceedings under this clause.

The venue of arbitration shall be the place from which the contract is issued.

Applicable Law: The contracts shall be interpreted in accordance with the laws of the Union of India.

Contracts with Partnership firm/ Joint Venture/ Consortium:

The Partnership firm/ Joint Venture/ Consortium is required to submit written consent of all the partners to above arbitration clause at the time of submission of bid.

43.0 The company reserves the right to deduct/withhold any amount towards taxes, levies, etc. and to deal with such amount in terms of the provisions of the Statute or in terms of the direction of any statutory authority and the company shall only provide with certificate towards such deduction and shall not be responsible for any reason whatsoever.

44.0 SITE VISIT

a) The bidder, at the Bidder's own responsibilities, cost and risk, is encouraged to visit and examine the Site of Works and its surrounding, approach road, soil condition, investigation report, existing works, if any, connected to the tendered work, drawings connected to the work, if / as available and obtain all information that may be necessary for preparing the Bid and entering

into a contract for execution of the works. The cost of visiting the Site shall be at the Bidder's own expense.

- b) It shall be deemed that the Bidder has visited the Site/Area and got fully acquainted with the working conditions and other prevalent conditions and fluctuations thereto whether he/she/they actually visits the Site /Area or not and has taken all the factors into account while quoting his/her/their rates.
- c) The Bidder is expected, before quoting his rate, to go through the requirement of materials/workmanship, specification, requirements and conditions of contract.
- d) The Bidder, in preparing the bid, shall rely on the site investigation report referred to in the bid document (if available), supplemented by any information available to the Bidder.

45.0 E-way Bill:

The e-way bill required in connection with supply of goods or services, if any, shall be arranged by the supplier/vendor. However, the e-way bill will be arranged by BCCL if the supplier/vendor is unregistered one or if provisions of the relevant Act and the rules made there under specifically states that three-way bill is required to be issued by recipient of goods.

46.0 In the event of recovery of any claim towards LD Charges, Penalty, fee, fine or any other charges from the supplier/vendor, the same will be recovered along with the applicable GST and the amount shall be adjusted with the payment to be made to the supplier/vendor against their bill/invoice or any other dues.

47.0 Discrepancies In Contract Documents & Adjustments Thereof

47.1 In the event of varying or conflicting provision in any of the document(s) forming part of the contract, the Accepting Authority's decision/clarification shall hold good with regard to the intention of the document or contract as the case may be.

47.2 Any error in description, quantity or rate in Bill of Quantities or any omission there from, shall not vitiate the contract or release the contractor from discharging his obligations under the contract including execution of work according to the Drawings and Specifications forming part of the particular contract document.

SECTION-3

ADDITIONAL TERMS & CONDITIONS OF CONTRACT

The following additional terms & conditions are also acceptable to the company. The tenderers shall not quote any additional conditions in their tender.

1. **MOBILISATION ADVANCE:**

Refer to **SPECIAL CONDITIONS OF CONTRACT (SECTION 6)**

2.0 PRICE VARIATION CLAUSE:

2.1 The contract price shall remain firm without any price variation except for Change in Law events as per relevant clauses in Special Conditions of Contract

SECTION - 4

GENERAL TECHNICAL CONDITIONS

1.0 GENERAL

This part covers technical conditions pursuant to the contract and will form an integral part of the contract. The following provisions shall be read in conjunction with the Technical Specifications of the Tender document. In case there is any conflict between the Technical Specifications and the General Technical Conditions as per this section, the conditions as per technical specifications shall prevail.

2.0 LIMIT OF CONTRACT

Equipment furnished shall be complete in every respect with all mountings, fittings, fixtures and standard accessories normally provided with such equipment and/or needed for erection, completion and safe operation of the equipment as required by applicable codes though they may not have been specifically detailed in the technical specifications unless included in the list of exclusions. All similar standard components/parts of similar standard equipment provided, shall be inter-changeable with one another.

3.0 EQUIPMENT PERFORMANCE GUARANTEE

3.1 The performance tests of the equipment under the scope of the contract are detailed in the technical specifications. These guarantees shall supplement the general performance guarantee provisions covered under general terms & conditions of contract in clause entitled "Guarantee".

3.2 Liquidated damages for not meeting performance guarantee during the performance and guarantee tests shall be assessed and recovered from the contractor, as detailed in the General Technical Conditions. Such liquidated damages shall be without any limitation whatsoever and shall be in addition to damages, if any payable under any other clauses of conditions of contract.

4.0 ENGINEERING DATA

4.1 The furnishing of engineering data by the contractor shall be in accordance with the schedule for each set of equipment as specified in the technical specifications. The review of these data by the Engineer-in-charge will cover only general conformance of the data to the specifications and documents, interfaces with the equipment provided under the specifications, external connections and of the dimensions which might affect plant layout. This review by the Engineer-in-Charge may not indicate a thorough review of all dimensions, quantities and details of the equipment, materials, any devices or items indicated or the accuracy of the information submitted. This review and/or approval by the engineer shall not be construed by the contractor, as limiting any of his responsibilities and liabilities for mistakes and deviations from the requirements, specified under these specifications and documents.

4.2 All engineering data submitted by the contractor after final process including review and approval by the engineer shall form part of the contract documents and the entire works covered under these specifications shall be performed in strict conformity, unless otherwise expressly requested by the Engineer-in-Charge in writing.

5.0 DRAWING

5.1 All drawings submitted by the contractor including those submitted at the time of bid shall

be sufficiently detailed to indicate the type, size, arrangement, weight of each component, break-up for packing and shipment, the external-connections, fixing arrangements required, the dimensions required for installation and inter-connections with other equipment and materials, clearances and spaces required between various portions of equipment and any other information specifically requested in the specifications.

5.2 Each drawing submitted by the contractor shall be clearly marked with the name of the owner, the unit designation, the specifications title, the specification number and the name of the project. If standard catalogue pages are submitted the applicable items shall be indicated therein. All titles, noting, markings and writings on the drawing shall be in English. All the dimensions should be in metric units.

5.3 The owner may use a 35 mm microfilm system in processing drawings. All drawings shall be suitable for microfilming. Drawings which are not suitable for microfilming will not be accepted. A copy of each drawings reviewed will be returned to the contractor as stipulated herein. The owner may also accept and use floppies/ disks for computer based drawings.

5.3.1 Copies of drawings returned to the contractor will be in the form of a print with the owner's marking, or a print made from a microfilm of the marked up drawing or in the form of aperture cards if the contractor has facilities to process such cards or print made from floppies for computer based drawings.

5.4 The drawings submitted by the contractor shall be reviewed by the Engineer-in-Charge as far as practicable within four (4) weeks and shall be modified by the contractor if any modifications and/or corrections are required by the Engineer-in-Charge. The contractor shall incorporate such modifications and/or corrections and submit the final drawings for approval. Any delay arising out of failure by the contractor to rectify the drawings in good time shall not alter the contract completion date and it will be on the Contractor's account.

5.5 Approval by the Nodal Officer or his Nominee: the Contractor shall submit specifications and drawings showing the proposed Temporary Works to the Nodal Officer/Engineer-in-charge or his Nominee, who is to approve them if they comply with the specifications and drawings. The Contractor shall be responsible for design of Temporary Works.

The Nodal Officer/Engineer -in-charge or nominee's approval shall not alter the contractor's responsibility for design of the Temporary Works.

5.6. The drawings sent for approval to the Engineer-in-Charge shall be in quintuplicate. One print of such drawings will be returned to the contractor by the Engineer-in-Charge marked approved/approved with corrections. The contractor shall thereupon furnish the owner with nine prints and one reproducible original of the drawings after incorporating all corrections.

5.7 Further work by the contractor shall be in strict accordance with these drawings and no deviation shall be permitted without the written approval of the Engineer-in-Charge, if so required.

5.8 All manufacturing and fabrication work in connection with the equipment prior to the approval of the drawings shall be at the contractor's risk. The contractor may make any changes in the design which are necessary to make the equipment conform, to the provisions and intent of the contract and such changes will again be subject to approval by the Engineer-in- Charge. Approval of contractor's drawings or work by the Engineer-in- Charge shall not relieve the contractor of any of his responsibilities and liabilities under the contract.

5.9 Drawings shall include all installation and detailed piping drawings wherever applicable. All piping 100 mm and larger shall be routed in detail and smaller pipe shall be shown schematically or by isometric drawings. All drawings shall be fully corrected to agree with actual as built construction.

5.10 Operating and Maintenance Manual: If “as built” drawings and/or operating and Maintenance Manuals are required the contractor shall supply them by the dates stated in the contract data.

If the Contractor does not supply the drawings and/or Manuals by the dates stated in the contract data, or they do not receive the Nodal Officer or his Nominee’s approval, the Nodal Officer or his Nominee shall withhold the amount stated in the contract data from payments due to the contractor.

6.0 INSTRUCTION MANUALS

6.1 The contractor shall submit to the Engineer-in-Charge, preliminary instruction manuals for all the equipment, covered under the contract within the time agreed upon between the owner & the contractor. The final instruction manuals complete in all respects shall be submitted by the contractor thirty (30) days before the first shipment of the equipment. The instruction manuals shall contain full details and drawings of all the equipment furnished, the erection procedures, testing procedures, operation and maintenance procedures of the equipment. These instruction manuals shall be submitted in the form of one (1) reproducible original and twelve (12) copies.

6.2 If after the commissioning and initial operation of the plant, the instruction manuals require any modifications/ additions/changes, the same shall be incorporated and the updated final instruction manuals in the form of one (1) reproducible original and twelve (12) copies shall be submitted by the contractor to the owner.

6.3 The contractor shall furnish to the owner spare parts catalogue.

6.4 In addition, the contractor shall supply two sets of all the document, specifications, operation and maintenance manuals (in hard copies also) and as built drawings in CDs/soft copy to CMPDI. The documents supplied shall be in easily readable, search & printable format.

7.0 FIRST FILL OF CONSUMABLE, OILS AND LUBRICANTS

All the first fill of consumable such as oils, lubricants and essential chemicals etc., which will be required to put the equipment covered under the scope of the specifications, into successful trial operation, shall be furnished by the contractor unless specifically excluded under the exclusions in the specifications and other documents.

8.0 MANUFACTURING SCHEDULE

The contractor shall submit to the Engineer-in-Charge his manufacture and delivery schedules for all equipment within thirty (30) days from the date of issuance of LOA. Such schedules shall be in line with the detailed network for all phases of the work of the contractor. Such schedules shall be reviewed, up-dated and submitted to the Engineer-in-Charge, once every two (2) months thereafter, by the contractor. Schedule shall also include the materials and equipment purchased from outside suppliers.

9.0 REFERENCE STANDARDS

9.1 The codes and / or standards referred to in these specifications shall govern, in all cases

wherever such references are made. In case of a conflict between such codes and/or standards and the specifications, the latter shall govern. Such codes and/or standards referred to shall mean the latest revisions, amendments/changes adopted and published by the relevant agencies. In case of any further conflict in this matter, the same shall be referred to the Engineer-in-Charge whose decision shall be final and binding.

- 9.2** Other internationally acceptable standards which ensure equal or higher performance than those specified shall also be accepted.

10.0 DESIGN IMPROVEMENT

- 10.1** The Engineer-in-Charge or the contractor may propose changes in the specification of the equipment or quality thereof and if the parties agree upon any such changes the specification shall be modified accordingly.

- 10.2** If any such agreed upon change is such that it affects the price and schedule of completion, the parties shall agree in writing as to the extent of any change in the price and/or schedule of completion before the contractor proceeds with the change. Following such agreement the provision thereof, shall be deemed to have been amended accordingly.

11.0 QUALITY ASSURANCE

11.1 Quality Assurance Program

To ensure that the equipment and services under the scope of this contract whether manufactured or performed within the contractor's works or at his sub-contractor's premises or at the owner's site or at any other place of work are in accordance with the specifications, the contractor shall adopt suitable quality assurance program to control such activities at all points necessary. Such program shall be outlined by the contractor before execution of agreement and will be submitted after LOA and shall be finally accepted by the Engineer-in-Charge after discussions before execution of job. A quality assurance program of the contractor shall generally cover the following:

- a.** his organization structure for the management and implementation of the proposed quality assurance program:
- b.** documentation control system:
- c.** qualification data for bidder's key personnel:
- d.** the procedure for purchase of materials, parts components and selection of sub-contractor's services including vendor analysis, source inspection, incoming raw-material inspection, verification of materials purchased etc.:
- e.** system for shop manufacturing and site erection control including process control and fabrication and assembly controls:
- f.** control of non-conforming items and system for corrective actions:
- g.** inspection and test procedure both for manufacture and field activities:
- h.** control of calibration and testing of measuring and testing equipment:
- i.** system for indication and appraisal of inspection status:
- j.** system for quality audits:
- k.** system for authorising release of manufactured product to the owner:
- l.** system for maintenance of records:

- m. system for handling storage and delivery: and
- n. a quality plan detailing out the specific quality control procedure adopted for controlling the quality characteristics relevant to each item of equipment furnished and each work at different stages executed at work site.

11.2 Quality Assurance Documents

The contractor shall be required to submit the following Quality Assurance Documents within three weeks after dispatch of the equipment.

- i. all non-destructive examination procedures stress relief and weld repair procedure actually used during fabrication.
- ii. welder and welding operator qualification certificates.
- iii. welder identification list, listing welder's and welding operator's qualification procedure and welding identification symbols.
- iv. material mill test reports on components as specified by the specification.
- v. the inspection plan with verification, inspection plan check points, verification sketches, if used, and methods used to verify that the inspection and testing points in the inspection plan were performed satisfactorily.
- vi. sketches and drawings used for indicating the method of traceability of the radiographs to the location on the equipment.
- vii. all non-destructive examination result reports including radiography interpretation reports.
- viii. stress relief time temperature charts.
- ix. factory test results for testing required as per applicable codes and standard referred in the specifications.
- x. the Engineer-in-Charge or his duly authorized representative reserves the right to carry out quality audit and quality surveillance of the systems and procedures of the contractor/his vendor's quality management and control activities.

12.0 ENGINEER'S SUPERVISION

12.1 To eliminate delays and avoid disputes and litigation it is agreed between the parties to the contract that all matters and questions shall be referred to the Engineer-in-Charge and his decision shall be final.

12.2 The work shall be performed under the direction and supervision of the Engineer-in-Charge. The scope of the duties of the Engineer-in-Charge, pursuant to the contract, will include but not be limited to the following:

- a. interpretation of all the terms and conditions of these documents and specification.
- b. review and interpretation of all the contractor's drawings, engineering data etc.
- c. witness or authorise his representative to witness tests and trials either at the manufacturer's works or at site, or at any place where work is performed under the contract.
- d. inspect, accept or reject any equipment, material and work under the contract.
- e. issue certificate of acceptance and/or progressive payment and final payment certificates.
- f. review and suggest modifications and improvements in completion schedules from time to time.
- g. supervise the quality assurance program implementation at all stages of the works.
- h. to receive and endorse the despatch documents enabling the contractor to clear the consignments.

13.0 INSPECTION, TESTING AND INSPECTION CERTIFICATE

- 13.1** The Engineer-in-Charge, his duly authorized representative and / or outside inspection agency acting on behalf of the owner shall have at all reasonable times access to the contractor's premises or works and shall have the power at all reasonable times to inspect and examine the materials and workmanship of the works during its manufacture or erection and if part of the works is being manufactured or assembled at other premises or works, the contractor shall obtain for the Engineer-in-Charge and for his duly authorized representative permission to inspect as if the works were manufactured or assembled on the contractor's own premises or works.
- 13.2** The contractor shall give the Engineer-in-Charge / Inspector fifteen (15) days written notice of any material being ready for testing. Such tests shall be to the contractor's account except for the expenses of the Inspector. The Engineer-in-Charge/Inspector, unless witnessing of the tests is virtually waived, will attend such tests within fifteen (15) days of the date on which the equipment is notified as being ready for test / inspection, failing which the contractor may proceed with the test which shall be deemed to have been made in the Inspector's presence and he shall forthwith forward to the Inspector duly certified copies of tests in triplicate.
- 13.3** The Engineer-in-Charge or Inspector shall within fifteen (15) days from the date of inspection as defined herein give notice in writing to the contractor, of any objection to any drawings and all or any equipment and workmanship which in his opinion is not in accordance with the contract. The contractor shall give due consideration to such objections and shall either make the modifications that may be necessary to meet the said objections or shall confirm in writing to the Engineer-in-Charge / Inspector giving reasons therein, that no modifications are necessary to comply with the contract.
- 13.4** When the factory tests have been completed at the contractor's or sub- contractor's works, the Engineer-in-Charge / Inspector shall issue a certificate to this effect within fifteen (15) days after completion of tests but if the tests are not witnessed by the Engineer-in-Charge/Inspector, the certificate shall be issued within fifteen (15) days of the receipt of the contractor's test certificate by the Engineer-in-Charge / Inspector. Failure of the Engineer-in-Charge/Inspector to issue such a certificate shall not prevent the contractor from proceeding with the works. The completion of these tests or the issue of the certificate shall not bind the owner to accept the equipment should it, on further tests after erection, be found not to comply with the contract.
- 13.5** In all cases where the contract provides for tests whether at the premises or works of the contractor or of any sub-contractor, the contractor, except where otherwise specified, shall provide free of charge such items as labor, materials, electricity, fuel, water, stores, apparatus and instruments as may be reasonably demanded by the Engineer-in-Charge/Inspector or his authorized representative to carry out effectively such tests of the equipment in accordance with the contract and shall be given facilities to the Engineer-in-Charge/Inspector or to his authorized representative to accomplish testing.
- 13.6** The inspection by Engineer-in-Charge and issue of Inspection Certificate thereon shall in no way limit the liabilities and responsibilities of the contractor in respect of the agreed quality assurance program forming a part of the contract.

14.0 TEST

14.1 Start up

- 14.1.1** On completion of erection of the equipment and before start-up, each item of the equipment shall be thoroughly cleaned and then inspected jointly by the Engineer-in-Charge and the contractor

for correctness and completeness of installation and acceptability of start-up, leading to initial pre-commissioning tests at site. The list of pre-commissioning tests to be performed shall be as mutually agreed and included in the contractor's quality assurance program.

14.1.2 The contractor's commissioning / start-up engineers specifically identified as far as possible shall be responsible for carrying out all the pre-commissioning tests. On completion of inspection, checking and after the pre-commissioning tests are satisfactorily over, the complete equipment shall be placed on initial operation during which period the complete equipment shall be operated integral with sub-systems and supporting equipment as a complete plant referred hereinafter as plant.

14.2 Trial Operation

14.2.1 The plant shall then be on trial operation during which period all necessary adjustments shall be made while operating over the full load-range enabling the plant to be made ready for performance and guarantee tests.

14.2.2 The duration of trial operation of the complete equipment shall be fourteen (14) days out of which at least seventy two (72) hours shall be continuous operation on full load or any other duration as may be agreed to, between the Engineer-in-Charge and the contractor. The trial operation shall be considered successful, provided that each item of the equipment can operate continuously at the specified operating characteristics, for the period of trial operation.

14.2.3 For the period of trial operation, the time of operation with any load shall be counted. Minor interruptions not exceeding four (4) hours at a time, caused during the continuous operation shall not affect the total duration of trial operation. However, if in the opinion of the Engineer-in-Charge, the interruption is long, the trial operation shall be prolonged for the period of interruption.

14.2.4 A trial operation report comprising of observations and recordings of various parameters to be measured in respect of the above trial operation shall be prepared by the contractor. This report, besides recording the details of the various observations during trial run, shall also include the dates of start and finish of the trial operations and shall be signed by the representatives of both the parties. The report shall have sheets, recording all the details of interruptions occurred, adjustments made and any minor repairs done during the trial operation. Based on the observations, necessary modifications / repairs to the plant shall be carried out by the contractor to the full satisfaction of the Engineer-in-Charge to enable the later to accord permission to carry out performance and guarantee tests on the plant. However, minor defects which do not endanger the safe operation of the equipment, shall not be considered as reasons for withholding the aforesaid permission.

14.3 Performance and guarantee test

14.3.1 The final test as to the performance and guarantees shall be conducted at site, by the owner. Such tests will be commenced within a period of two (2) months after successful completion of trial operations. Any extension of time beyond the above two (2) months shall be mutually agreed upon.

14.3.2 These tests shall be binding on both the parties of the contract to determine compliance of the equipment with the performance guarantees.

- 14.3.3** The available instrumentation and control equipment will be used during such tests and the Engineer-in-Charge will calibrate all such measuring equipment and devices as far as practicable. However, un-measurable parameters shall be taken into account in a reasonable manner by the Engineer-in-Charge, for the equipment of these tests. The tests will be conducted at the specified load points and as near the specified cycle condition as practicable. The Engineer-in-Charge will apply proper corrections in calculation, to take into account conditions which do not correspond to the specified conditions.
- 14.3.4** Any special equipment, tools and tackles required for the successful completion of the performance and guarantee tests, other than those accounted for by the Contractor in the BOQ sheet of its Bid, shall be provided by the Contractor, free of cost.
- 14.3.5** The guaranteed performance figures of the equipment shall be proved by the contractor during these performance and guarantee tests. Should the results of these tests show any decrease from the guaranteed values, the contractor shall modify the equipment as required to enable it to meet the guarantees. In such case, performance and guarantee tests shall be repeated within one month, from the date the equipment is ready for re-tests and all cost for modifications including labour, materials and the cost of additional testing to prove that the equipment meets the guarantees, shall be borne by the contractor. Duration of performance guarantee tests will be of one month of which 6 (six) days continuous on load operation is the minimum requirement and in case it fails, the process of performance guarantee tests will be repeated.
- 14.3.6** The specific tests to be conducted on equipment has been brought out in the technical specifications.
- 14.3.7** Performance and guarantee test shall make allowance for instrumentation errors as may be decided by the engineer-in-charge.

14.4 Test Codes

The provisions outlined in the ASME performance test codes or other international and Indian approved equivalents shall generally be used as a guide for all the above test procedures unless otherwise specified in the technical specifications.

15.0 PACKING

- 15.1** All the equipment shall be suitably protected, coated, covered or boxed and crated to prevent damage or deterioration during transit, handling and storage at site till the time of erection. While packing all the materials, the limitation from the point of view of availability of railway wagon sizes in India should be taken into account. The contractor shall be responsible for any loss or damage during transportation, handling and storage due to improper packing.

16.0 PROTECTION

All coated surfaces shall be protected against abrasions, impact, discoloration and any other damages. All exposed threaded portions shall be suitably protected with either a metallic or a non-metallic protecting device. All ends of all valves and piping and conduit equipment connections shall be properly sealed with suitable devices to protect them from damage. The parts which are likely to get rusted, due to exposure to weather, should also be properly treated and protected in a suitable manner.

17.0 PRESERVATIVE SHOP COATING

17.1 As per Technical Specifications of the Tender

18.0 PROTECTIVE GUARDS

Suitable guards shall be provided for protection of personnel on all exposed rotating and/or moving machine parts. All such guards with necessary spares and accessories shall be designed for easy installation and removal for maintenance purposes.

19.0 DESIGN CO-ORDINATION

The contractor shall be responsible for the selection and design of appropriate equipment to provide the best co-ordinated performance of the entire system. The basic design requirements are detailed out in Technical Specifications. The design of various components, sub-assemblies and assemblies shall be so done, so that it facilitates easy field assembly and maintenance. All the rotating components shall be so selected that the natural frequency of the complete unit is not critical or close to the operating range of the unit.

20.0 DESIGN CO-ORDINATION MEETING

The contractor will be called upon to attend design co-ordination meetings with the Engineer-in-Charge, other contractors and the consultants of the owner during the period of contract. The contractor shall attend such meetings at his own cost at the venue advised by the Owner as and when required and fully co-operate with such persons and agencies involved during those discussions.

21.0 TOOLS AND TACKLES

The contractor shall supply with the equipment one complete set of all special tools and tackles for the erection, assembly, dis-assembly and maintenance of the equipment. However, these tools and tackles shall be separately packed and brought on to site.

22.0 NOISE LEVEL

The equivalent 'A' weighted sound level measured at a distance of 1.5 meters above floor level in elevation and one meter horizontally from the base of any equipment furnished and installed under these specifications, expressed in decibels to a reference of 0.0002 microbar, shall not exceed 85 dBA.

23.0 TAKING OVER

Upon successful completion of all the tests to be performed at site on equipment furnished and erected by the contractor, the Engineer-in-Charge shall issue to the contractor a taking over certificate as a proof of the final acceptance of the equipment. Such certificate shall not unreasonably be withheld nor will Engineer-in-Charge delay the issuance thereof, on account of minor omissions or defects which do not affect the commercial operation and/or cause any serious risk to the equipment. Such certificate shall not relieve the contractor of any of his obligations which otherwise survive, by the terms and conditions of the contract after issuance of such certificate.

24.0 INDIAN STANDARDS

Normally Indian Standards as published by BUREAU OF INDIAN STANDARDS shall be followed. Wherever relevant Indian Standard is not published by the BIS, International Standards or American Standard or German Standard or British Standard, as decided by the Engineer-in-Charge in consultations with the Consultants employed by the Owner, shall be followed.

25.0 WELDING

If the manufacturer has special requirements relating to the welding procedures for welds at the terminals of the equipment to be procured by the owner under separate specifications, the requirements shall be submitted to the Engineer-in-Charge in advance of commencement of erection work.

26.0 LUBRICATION

Equipment shall be lubricated by systems designed for continuous operation. Lubricant level indicators shall be furnished and marked to indicate proper levels under both stand-still and operating conditions.

27.0 EQUIPMENT BASES

A cast iron or welded steel base plate shall be provided for all rotating equipment which is to be installed on a concrete/structural steel base unless otherwise agreed to by the Engineer-in-Charge. Each base plate shall support the unit and its drive assembly, shall be of a neat design with pads for anchoring the units, shall have a raised lip all around, and shall have threaded drain connections.

28.0 RATING PLATES, NAME PLATES AND LABELS

28.1 Each main and auxiliary items of plant is to have permanently attached to it in a conspicuous position a rating plate of non corrosive material upon which is to be engraved the manufacturer's name, equipment, type or serial number, together with details of the loading conditions under which the item of plant in question have been designed to operate, and such diagram plates as may be required by the Engineer-in-Charge.

28.2 Each item of plant is to be provided with a nameplate or label designating the service of the particular equipment. The inscriptions are to be approved by the Engineer-in-Charge or shall be as detailed in the appropriate sections of the technical specifications.

28.3 Such nameplates or labels are to be of white non- hygroscopic material with engraved black lettering or, al tentatively, in the case of indoor circuit breakers, starters etc. of transparent plastic material with suitably colored lettering engraved on the back.

28.4 Items of plant such as valves, which are subject to handling, are to be provided with an engraved chromium plated nameplate or label with engraving filled with enamel.

28.5 All such name plates, instruction plates, lubrication charts etc. shall be Bilingual with Hindi inscription first, followed by English. Alternatively two separate plates one with Hindi and the other with English inscriptions may be provided.

29.0 COLOUR CODE FOR PIPE SERVICES

All pipe services wherever applicable are to be painted in accordance with the owner's standard color scheme, by the contractor.

30.0 SERVICE BY THE OWNER

30.1 The following services shall be arranged by the Contractor

- i.** Drinking water and water required for the work to be arranged by the Contractor along with cost.
- ii.** Electricity at the work site is to be arranged by the Contractor and charges to be borne by the Contractor

30.2 Also in the event of the contractor requiring these services at parameters other than those specified above (at site), for any systems, equipment, instrument etc. he shall make the necessary arrangements himself.

SECTION - 5

ERECTION CONDITIONS OF CONTRACT

1.0 GENERAL

1.1 The following provisions shall be read in conjunction with the Technical Specifications stipulated in the Tender document. In case there is any conflict between the Technical Specifications and the Erection Conditions of Contract as per this section, the conditions as per Technical Specifications shall prevail.

1.2 The contractor upon signing of the contract shall, in addition to a Project Co-ordinator, nominate another responsible Officer as his representative at site suitably designated for the purpose of overall responsibility and co-ordination of the works to be performed at site. Such person shall function from the site office of the contractor during the pendency of contract.

2.0 REGULATION OF LOCAL AUTHORITIES AND STATUTES

2.1 The contractor shall comply with all the rules and regulations of local authorities during the performance of his field activities. He shall also comply with the minimum wages act, 1948 and the payment of wages act (both of the Government of India and the local State Government) and the rules made thereunder in respect of any employee or workman employed or engaged by him or his sub - contractor. The contractor shall make all necessary payments of the Provident Fund for the workmen employed by him for the work as per the laws prevailing under provisions of CMPF/EPF and Allied Schemes and CMPF/EPF and Miscellaneous Provisions Act 1948 and Miscellaneous Provisions Act 1952 as the case may be.

2.2 All registration and statutory inspection fees, if any, in respect of his work pursuant to this contract shall be to the account of the contractor. However, any registration, statutory inspection fees lawfully payable under the provisions of the rules and regulations of the Government and any other statutory laws and its amendments from time to time during erection in respect of the plant equipment ultimately to be owned by the owner, shall be to the account of the owner. Should any such inspection or registration need to be arranged due to the fault of the contractor or his sub - contractor, the additional fees for such inspection and/or registration shall be borne by the contractor.

3.0 OWNER'S LIEN ON EQUIPMENT

The owner shall have lien on all equipment including those of the contractor brought to the site for the purpose of erection, testing and commissioning of the plant. The owner shall continue to hold the lien on all such equipment

throughout the period of contract. No material brought to the site shall be removed from the site by the contractor and/or his sub-contractors without the prior written approval of the Engineer-in-Charge.

4.0 INSPECTION, TESTING AND INSPECTION CERTIFICATES

The provisions of the clause entitled inspection testing and inspection certificates under section GTC shall also be applicable to the erection portion of the works. The Engineer-in-Charge shall have the right to re-inspect any equipment though previously inspected and approved by him, at the contractor's works, before and after the same are constructed and/or erected at site. If by the above inspection, the Engineer-in-Charge rejects any work or equipment, the contractor shall make good for such rejection either by replacement or modifications/ repairs as may be necessary, to the satisfaction of the Engineer-in-Charge. Such replacement will also include the replacement or re-execution of such of those works of other contractors and/or agencies, which might have got damaged or affected by the replacements or re-work done to the contractor's work.

5.0 ACCESS TO SITE AND WORKS ON SITE

- a)** The bidder, at the Bidder's own responsibilities, cost and risk, is encouraged to visit and examine the Site of Works and its surrounding, approach road, soil condition, investigation report, existing works, if any, connected to the tendered work, drawings connected to the work, if / as available and obtain all information that may be necessary for preparing the Bid and entering into a contract for execution of the works. The cost of visiting the Site shall be at the Bidder's own expense.
- b)** It shall be deemed that the Bidder has visited the Site/Area and got fully acquainted with the working conditions and other prevalent conditions and fluctuations thereto whether he/she/they actually visits the Site /Area or not and has taken all the factors into account while quoting his/her/their rates.
- c)** The Bidder is expected, before quoting his rate, to go through the requirement of materials/workmanship, specification, requirements and conditions of contract.
- d)** The Bidder, in preparing the bid, shall rely on the site investigation report referred to in the bid document (if available), supplemented by any information available to the Bidder.

6.0 CONTRACTOR'S SITE OFFICE ESTABLISHMENT

The contractor shall establish a site office at the site and keep posted an authorized representative for the purpose of the contract. Any written order or instruction of the Engineer-in-Charge or his duly authorized representative, shall be communicated to the said authorized resident representing the contractor and the same shall be deemed to have been communicated to the contractor at his legal address.

7.0 CO-OPERATION WITH OTHER CONTRACTORS

7.1 The contractor shall co-operate with all other contractors or tradesmen of the owner, who may be performing other works on behalf of the owner and the workmen who may be employed by the owner and doing work in the vicinity of the works under the contract. The contractor shall also so arrange to perform his work as to minimize, to the maximum extent possible, interference with the work of other contractors and his workmen. Any injury or damage that may be sustained in the employees of the other contractors and the owner, due to the contractor's work shall promptly be made good at his own expense. The Engineer-in-Charge shall determine the resolution of any difference or conflict that may arise between the contractor and other contractors or between the contractor and the workmen of the owner in regard to their work. If the works of the contractor is delayed because of any acts or omissions of another contractor, the contractor shall have no claim against the owner on that account other than an extension of time for completing his works

7.2 The Engineer-in-Charge shall be notified promptly by the contractor of any defects in the other contractor's works that could affect the contractor's works. The Engineer-in-Charge shall determine the corrective measures if any, required to rectify this situation after inspection of the works and such decisions by the Engineer-in-Charge shall be binding on the contractor.

8.0 DISCIPLINE OF WORKMEN

The contractor shall adhere to the disciplinary procedure set by the Engineer-in-Charge in respect of his employees and workmen at site. The Engineer-in-Charge shall be at liberty to object to the presence of any representative or employees of the contractor at the site, if in the opinion of the Engineer-in-Charge such employee has mis-conducted himself or be incompetent or negligent or otherwise undesirable and then the contractor shall remove such a person objected to and provide in his place a competent replacement.

9.0 CONTRACTOR'S FIELD OPERATION

9.1 The contractor shall keep the Engineer-in-Charge informed in advance regarding his field activity plans and schedules for carrying out each part of the works. Any review of such plan or schedule or method of work by the Engineer-in-Charge shall not relieve the contractor of any of his responsibilities towards the field activities. Such reviews shall also not be considered as an assumption of any risk or liability by the Engineer-in-Charge or the owner or any of his representatives and no claim of the contractor will be entertained because of the failure or inefficiency of any such plan or schedule or method of work reviewed. The contractor shall be solely responsible for the safety, adequacy and efficiency of plant and equipment and his erection methods.

9.2 The contractor shall have complete responsibility for the conditions of the work site including the safety of all persons employed by him or his sub-contractor and all the properties under his custody during the performance of the work. This requirement shall apply continuously till the completion of the contract and shall not be limited to normal working hours. The construction review by the Engineer-in-Charge is not intended to include review of contractor's safety measures in, on or near the work-site, and their adequacy or otherwise.

10.0 PHOTOGRAPHS AND PROGRESS REPORT

10.1 The contractor shall furnish three (3) prints each to the Engineer-in-Charge of progress photographs of the work done at site. Photographs shall be taken as and when indicated by the Engineer-in-Charge or his representative. Photographs shall be adequate in size and number to indicate various stages of erection. Each photograph shall contain the date , the name of the contractor and the title of the photograph.

10.2 The above photographs shall accompany the monthly progress report detailing out the progress achieved on all erection activities as compared to the schedules. The report shall also indicate the reasons for the variance between the scheduled and actual progress and the action proposed for corrective measures wherever necessary.

11.0 MAN-POWER REPORT

11.1 The contractor shall submit to the Engineer-in-Charge, on the first day of every month, a man hour schedule for the month, detailing the man hours scheduled for the month, skill wise and area -wise.

11.2 The contractor shall also submit to the Engineer-in-Charge on the first day of every month, a man power report of the previous months detailing the number of persons scheduled to have been employed and actually employed, skill -wise and areas of employment of such labor.

12.0 PROTECTION WORK

The contractor shall have total responsibility for protecting his works till it is finally taken over by the Engineer-in-Charge. No claim will be entertained by the owner or the Engineer-in-Charge for any damage or loss to the contractor's works and the contractor shall be responsible for the complete restoration of the damaged works to its original condition to comply with the specifications and drawings. Should any such damage to the contractor's works occur because of other party not under his supervision or control, the contractor shall make his claim directly with the party concerned. If dis-agreement or conflict or dispute develops between the contractor and the other party or parties concerned regarding the responsibility for damage to the contractor's works the same shall be resolved as per the provisions of the clause 7.0 above entitled co- operation with other contractors. The contractor shall not cause any delay in the repair of such damaged works because of any delay in the resolution of such disputes. The contractor shall proceed to repair the work immediately and the cause thereof will be assigned pending resolution of such dispute.

13.0 EMPLOYMENT OF LABOUR

13.1 Contractors are to employ, to the extent possible (as per policy decision of the company valid from time to time), local project affected people and pay wages not less than the minimum wages as per minimum Wages Act of Central or state govt. (whichever is higher).

Payment of Provident Fund for the workmen employed by him for the work as per the Law prevailing under provision of CMPF/EPF and allied scheme valid from time to time shall be responsibility of the contractor.

In all the cases mentioned above, the contractor needs to ensure that the employee has become a member of any of the provident fund as the case may be and the unique membership number

of the CMPF/EPF or Allied Scheme needs to be submitted to Employer.

In addition to the above, the Contractor shall provide a copy of the updated passbook having entry made in the CMPF/EPF or Allied Scheme(s) of Provident fund as the case may be by the competent authority annually/as and when asked. Bidder shall also submit copies of statutory returns.

- 13.2** The Contractor shall comply with statutory requirements of various acts including Child Labor (Prohibition & Regulation) Act, 1986 as amended from time to time and all rules, regulations and schemes framed there under from time to time in addition to other applicable labor laws.
- 13.3** The payment to the contractor's laborers has to be made through Bank only.
- 13.4** Bonus is to be paid to the contract workers engaged by the Contractors as per the provisions of Payment of Bonus Act, 1965 as amended from time to time.
- 13.5** The contractors shall register themselves on the Contract Labor Payment Management Portal (CLPMP) of CIL within 30 days of issue of work order and will have to enter and update periodically the following details in the portal:
- a.** Work Order details
 - b.** Details of Contractor workers and payment of wages in respect of each Work Order each month.
- 13.6** All the contract workers shall be covered with the Bio-metric attendance system for payment of wages.
- 13.7** Contractors should deploy suitably experienced workers as mentioned in relevant Govt. circular.
- 14.0 FACILITIES TO BE PROVIDED BY THE CONTRACTOR**
- 14.1 SPACE:**
- The contractor shall arrange space for his office, mess-rooms storage area, pre-assembly and fabrication areas, labor colony area, toilets, etc.
- 14.2 ELECTRICITY:**
- The contractor shall arrange for electrical distribution in the project site. The contractor shall make his own further distribution arrangement. All temporary wiring must comply with local regulations and will be subject to Engineer-in-Charge's inspection and approval before connection to supply. Power supply for labor colonies shall also be arranged by the Contractor. The contractor shall pay at prevalent rate of power supplied by State Electricity Board.
- 14.3 WATER:**
- Supply of water will be made available by the Contractor. And further distribution will be the responsibility of the contractor. The contractor shall have to do their own arrangement for construction water at site. In case the owner arrange to supply the water for construction purpose at site, the contractor shall be charged @ 1% of the value of civil works and shall be

deducted from the contractor's running/final bills.

15.0 FACILITIES TO BE PROVIDED BY THE CONTRACTOR

15.1 Tools, tackles and scaffoldings

The contractor shall provide all the construction equipment, tools, tackles and scaffoldings required for pre-assembly, erection, testing and commissioning of the equipment covered under the contract. He shall submit a list of all such materials to the Engineer-in-Charge before the commencement of pre- assembly at site. These tools and tackles shall not be removed from the site without the written permission of the Engineer-in- Charge.

15.2 Communication

The Contractor has to extend the telephone & telex facilities for purposes of contract. The contractor shall pay for the same.

15.3 First – aid

15.3.1 The contractor shall provide necessary first -aid facilities for all his employees, representatives and workmen working at the site. Enough number of contractor's personnel shall be trained in administering first-aid.

15.3.2 The contractor, in case of an emergency, has to provide the services of an ambulance for transportation to the nearest hospital.

15.4 Cleanliness

15.4.1 The contractor shall be responsible for keeping the entire area allotted to him clean and free from rubbish, debris etc. during the period of contract. The contractor shall employ enough number of special personnel to thoroughly clean his work area at least once in a day. All such rubbish and scrap material shall be stacked or disposed in a place to be identified by the Engineer-in-Charge. Materials and stores shall be so arranged to permit easy cleaning of the area in Project Site where equipment might drip oil and cause damage to the floor surface, a suitable protective cover of a flame resistant, oil proof sheet shall be provided to protect the floor from such damage.

15.4.2 Similarly the labor colony, the offices and the residential areas of the contractor's employees and workmen shall be kept clean and neat to the entire satisfaction of the Engineer-in-Charge. Proper sanitary arrangement shall be provided by the contractor, in the work areas, office and residential areas of the contractor.

16.0 LINES AND GRADES

All the works shall be performed to the lines, grades and elevations indicated on the drawings. The contractor shall be responsible to locate and layout the works. Basic horizontal and vertical control points will be established and marked by the Engineer-in-Charge at site at suitable points. These points shall be used as datum for the works under the contract. The contractor shall inform the Engineer-in-Charge well in advance of the times and places at which he wishes to do work in the area allotted to him, so that suitable datum points may be established and checked by the Engineer-in-Charge to enable the contractor to proceed with

his works. Any work done without being properly located may be removed and/or dismantled by the Engineer-in-Charge at contractor's expense.

17.0 FIRE PROTECTION

- 17.1** The work procedures that are to be used during the erection shall be those which minimize fire hazards to the extent practicable. Combustible materials, combustible waste and rubbish shall be collected and removed from the site at least once each day. Fuels, oils and volatile or flammable materials shall be stored away from the construction and equipment and materials storage areas in safe containers. Untreated canvas paper, plastic or other flammable flexible materials shall not at all be used at site for any other purpose unless otherwise specified. If any such materials are received with the equipment at the site, the same shall be removed and replaced with acceptable material before moving into the construction area or storage.
- 17.2** Similarly corrugated paper fabricated cartons etc. will not be permitted in the construction area either for storage or for handling of materials. All such materials used shall be water proof and flame resistant type. All the other materials such as working drawings, plants, etc. which are combustible but are essential for the works to be executed shall be protected against combustion resulting from welding sparks, cutting flames and other similar fire sources.
- 17.3** All the contractor's supervisory personnel and sufficient number of workers shall be trained for fire - fighting and shall be assigned specific fire protection duties. Enough of such trained personnel must be available at the site during the entire period of the contract.
- 17.4** The contractor shall provide enough fire protection equipment of the types and number for the ware - houses, office, temporary structures, labor colony area etc. Access to such fire protection equipment, shall be easy and kept open at all times.

18.0 SECURITY

The contractor shall have total responsibility for all equipment and materials in his custody stored, loose, semi-assembled and/or erected by him at site. The contractor shall make suitable security arrangements including employment of security personnel to ensure the protection of all materials, equipment and works from theft, fire, pilferage and any other damages and loss. All materials of the contractor shall enter and leave the project site only with the written permission of the Engineer-in-Charge in the prescribed manner.

19.0 CONTRACTOR'S AREA LIMITS

The Engineer-in-Charge will mark-out the boundary limits of access roads, parking spaces, storage and construction areas for the contractor and the contractor shall not trespass the areas not so marked out for him. The contractor shall be responsible to ensure that none of his personnel move out of the areas marked out for his operations. In case of such a need for the contractor's personnel to work out of the areas marked out for him, the same shall be done only with the written permission of the Engineer-in-Charge.

20.0 CONTRACTOR'S CO-OPERATION WITH THE OWNER

In cases where the performance of the erection work by the contractor affects the operation of the system facilities of the owner, such erection work of the contractor shall be scheduled to be performed only in the manner stipulated by the Engineer-in-Charge and the same shall be acceptable at all times to the contractor. The Engineer-in-Charge may impose such restrictions on the facilities provided to the contractor such as electricity, water, etc. as he may think fit in the interest of the owner and the contractor shall strictly adhere etc. such restrictions and co-operate with the Engineer-in-Charge. It will be the responsibility of the contractor to provide all necessary temporary instrumentation and other measuring devices required during start-up and operation of the equipment systems, which are erected by him. The contractor shall also be responsible for flushing and initial filling of all the oil and lubricants required for the equipment furnished and erected by him, so as to make such equipment ready for operation. The contractor shall be responsible for supplying such flushing oil and other lubricants unless otherwise specified elsewhere in these documents & specifications.

21.0 PRE-COMMISSIONING TRIALS AND INITIAL OPERATIONS

The pre-commissioning trials and initial operations of the equipment furnished and erected by the contractor shall be the responsibility of the contractor as detailed in relevant clauses in section GTC. The contractor shall provide, in addition, test instruments, calibrating devices, etc. and the labor required for the successful performance of these trials. It is anticipated that the above test may prolong for a long time, the contractor's workmen required for the above test shall always be present at site during such trials.

22.0 MATERIALS HANDLING AND STORAGE

- 22.1** All the equipment furnished under the contract and arriving at site shall be promptly received, unloaded and transported and stored in the storage spaces by the contractor.
- 22.2** Contractor shall be responsible for examining all the shipment and notify the Engineer-in-Charge immediately or any damage, shortage, discrepancy, etc. for the purpose of Engineer-in-Charge's information only. The contractor shall submit to the Engineer-in-Charge every week a report detailing all the receipts during the week. However, the contractor shall be solely responsible for any shortages or damage in transit, handling and/or in storage and erection of the equipment at the site. Any demurrage, wharfage and other such charges claimed by the transporters, railways etc. shall be to the account of the contractor.
- 22.3** The contractor shall maintain an accurate and exhaustive record detailing out the list of all equipment received by him for the purpose of erection and keep such record open for the inspection of the Engineer-in-Charge at any time.
- 22.4** All equipment shall be handled very carefully to prevent any damage or loss. No bare wire ropes, slings, etc. shall be used for unloading and/or handling of the equipment without the specific written permission of the Engineer-in-Charge. The equipment stored shall be properly protected to prevent damage either to the equipment or to the floor where they are stored. The equipment from the store shall be moved to the actual location at the appropriate time so as to avoid damage of such equipment at site.
- 22.5** All electrical panels, control gear, motors and such other devices shall be properly dried by heating before they are installed and energized. Motor bearings, slip rings, commutators and

other exposed parts shall be protected against moisture ingress and corrosion during storage and periodically inspected. Heavy rotating parts in assembled conditions shall be periodically rotated to prevent corrosion due to prolonged storage.

- 22.6** All the electrical equipment such as motors, generators, etc. shall be tested for insulation resistance at least once in three months from the date of receipt till the date of commissioning and a record of such measured insulation values maintained by the contractor. Such records shall be open for inspection by the Engineer-in-Charge.
- 22.7** The contractor shall ensure that all the packing materials and protection devices used for the various equipment during transit and storage are removed before the equipment are installed.
- 22.8** The consumable and other supplies likely to deteriorate due to storage must be thoroughly protected and stored in a suitable manner to prevent damage or deterioration in quality by storage.
- 22.9** All the materials stored in the open or duty location must be covered with suitable weather-proof and flameproof covering materials wherever applicable.
- 22.10** If the materials belonging to the contractor are stored in areas other than those earmarked for him, the Engineer-in-Charge will have the right to get it moved to the area earmarked for the contractor at the contractor's cost.
- 22.11** The contractor shall be responsible for making suitable indoor storage facilities to store all equipment which require indoor storage. Normally, all the electrical equipment such as motors, control gear, generators, exciters and consumable like electrodes, lubricants etc. shall be stored in the closed storage space. The Engineer-in-Charge, in addition, may direct the contractor to move certain other materials which in his opinion will require indoor storage, to indoor storage areas which the contractor shall strictly comply with.

23.0 CONSTRUCTION MANAGEMENT

- 23.1** The field activities of the contractors working at site, will be coordinated by the Engineer-in-Charge and the Engineer-in-Charge's decision shall be final in resolving any disputes or conflicts between the contractor and other contractors and tradesmen of the owner regarding scheduling and co-ordination of work. Such decision by the Engineer-in-Charge shall not be a cause for extra compensation or extension of time for the contractor.
- 23.2** The Engineer-in-Charge shall hold weekly meetings of all the contractors working at site, at a time and a place to be designated by the Engineer-in-Charge. The contractor shall attend such meetings and take notes of discussions during the meeting and the decisions of the Engineer-in-Charge and shall strictly adhere to those decisions in performing his works. In addition to the above weekly meetings, the Engineer-in-Charge may call for other meetings either with individual contractors or with selected number of contractors and in such a case the contractor, if called will also attend such meetings.
- 23.3** Time is the essence of the contract and the contractor shall be responsible for performance of this works in accordance with the specified construction schedule. If at any time, the contractor is falling behind the schedule, he shall take necessary action to make good for such delays by increasing his work force or by working overtime or otherwise accelerate the progress of the work to comply with the schedule and shall communicate such actions in writing to the Engineer-in-Charge, satisfying that his action will compensate for the delay. The contractor

shall not be allowed any extra compensation for such action.

- 23.4** The Engineer-in-Charge shall however not be responsible for provision of additional labor and/or materials or supply or any other services to the contractor except for the co-ordination work between various contractors as set out earlier.

24.0 FIELD OFFICE RECORDS

The contractor shall maintain at his site office up- to- date copies of all drawings, specifications and other contract documents and any other supplementary data complete with all the latest revisions thereto. The contractor shall also maintain in addition the continuous record of all changes to the above contract documents, drawings, specifications, supplementary data, etc. effected at the field and on completion of his total assignment under the contract shall incorporate all such changes on the drawings and other engineering data to indicate as installed condition of the equipment furnished and erected under the contract. Such drawings and engineering data shall be submitted to the Engineer-in-Charge in required number of copies. Daily work program with progress of the previous day and deployment of labor related to work program and attendance of workmen deployed during the previous day shall be maintained in a register. This register shall be signed by authorized representative of the contractor which will then be checked and signed by the owner's representative. Every three months this register shall be deposited to the owner which shall then be owner's property.

25.0 CONTRACTOR'S MATERIALS BROUGHT ON TO SITE

- 25.1** The contractor shall bring to site all equipment, parts, materials, including construction equipment, tools and tackles for the purpose of the works with intimation to the Engineer-in-Charge. All such goods shall, from the time of their being brought, vest in the owner, but may be used for the purpose of the works only and shall not on any account be removed or taken away by the contractor without the written permission of the Engineer-in-Charge. The contractor shall nevertheless be solely liable and responsible for any loss or destruction thereof and damage thereto.

- 25.2** The owner shall have a lien on such goods for any sum or sums which may at any time be due or owing to him by the contractor, under, in respect of or by reasons of the contract. After giving a fifteen (15) days' notice in writing of his intention to do so, the owner shall be at liberty to sell and dispose of any such goods, in such manner as he shall think fit including public auction or private treaty and to apply the proceeds in or towards the satisfaction of such sum or sums due as aforesaid.

- 25.3** After the completion of the works, the contractor shall remove from the site under the direction of the Engineer-in-Charge the materials such as construction equipment, erection tools and tackles, scaffolding etc. with the written permission of the Engineer-in-Charge. If the contractor fails to remove such materials, within 15 days of issue of a notice by the Engineer- in-Charge to do so then the Engineer-in-Charge shall have the liberty to dispose of such materials as detailed under clause 25.2 above and credit the proceeds thereto the account of the contractor.

26.0 PROTECTION OF PROPERTY AND CONTRACTOR'S LIABILITY

- 26.1** The contractor shall be responsible for any damage resulting from his operations. He shall also be responsible for protection of all persons including members of public and employees

of the owner and the employees of other contractors and sub-contractors and all public and private property including structures, buildings, other plants and equipment and utilities either above or below the ground.

26.2 The contractor will ensure provision of necessary safety equipment such as barriers, sign-boards, warning lights and alarms, etc. to provide adequate protection to persons and property. The contractor shall be responsible to give reasonable notice to the Engineer-in-Charge and the owners of public or private property and utilities when such property and utilities are likely to get damaged or injured during the performance of his works and shall make all necessary arrangements with such owners, related to removal and/or replacement or protection of such property and utilities.

27.0 PAINTING

All exposed metal parts of the equipment including piping, structure railing etc. wherever applicable, after installation unless otherwise surface protected, shall be first painted with at least one coat of suitable primer which matches the shop primer paint used, after thoroughly cleaning all such parts of all dirt, rust, scales, greases, oils and other foreign materials by wire brushing, scraping or sand blasting, and the same being inspected and approved by the Engineer-in-Charge for painting. Afterwards, the above parts shall be finished with two coats of alloyed resin machinery enamel paints. The quality of the finish paint shall be as per the standards of ISI or equivalent and to be of the color as approved by the Engineer-in-Charge.

28.0 INSURANCE

28.1 In addition to the conditions covered under the clause entitled insurance in general terms and conditions of contract, the following provisions will also apply to the portion of the works to be done beyond the contractor's own or his sub-contractor's works.

28.2 Workmen's compensation insurance

This insurance shall protect the contractor against all claims applicable under the Workmen's Compensation Act 1948 (Government of India). This policy shall also cover the contractor against claims for injury, disability, disease or death of his or his sub-contractor's employees, which for any reason are not covered under the Workmen's Compensation Act 1948. The liabilities shall not be less than

Workmen's compensation	As per statutory provisions
Employer's liability	As per statutory provisions

28.3 Comprehensive Automobile Insurance

This insurance shall be in such a form to protect the contractor against all claims for injuries, disability, disease and death to members of public including the owner's men and damage to the property of others arising from the use of motor vehicles during on or off the site operations, irrespective of the ownership of such vehicles.

28.4 Comprehensive General Liability Insurance

28.4.1 This insurance shall protect the contractor against all claims arising from injuries, disabilities, disease or death of members of public or damage to property of others, due to any act or omission on the part of the contractor, his agents, his employees, his

representatives and sub- contractors or from riots, strikes and civil commotion. The insurance shall also cover all the liabilities of the contractor arising out of the clause entitled defense of suits under General Terms and Conditions of contract.

28.4.2 The hazards to be covered will pertain to all the works which and areas where the contractor, his sub-contractors, his agents and his employees have to perform work pursuant to the contract.

28.5 The above are only illustrative list of insurance covers normally required and it will be the responsibility of the contractor to maintain all necessary insurance coverage to the extent both in time and amount to take care of all his liabilities either direct or indirect, in pursuance of the contract.

29.0 UNFAVOURABLE WORKING CONDITIONS

The contractor shall confine all his field operations to those works which can be performed without subjecting the equipment and materials to adverse effects, during inclement weather conditions, like monsoon, storms, etc. and during other unfavorable construction conditions. No field activities shall be performed by the contractor under conditions which might adversely affect quality and efficiency thereof, unless special precautions or measures are taken by the contractor in a proper and satisfactory manner in performance of such works and with concurrence of the Engineer-in- Charge. Such unfavorable construction conditions will in no way relieve the contractor of his responsibility to perform works as per the schedule.

30.0 PROTECTION OF MONUMENTS AND REFERENCE POINTS

The contractor shall ensure that any finds such as relic, antiquity, coins, fossils, etc. which he might come across during the course of performance of his works either during excavation or elsewhere, are properly protected and handed over to the Engineer-in-Charge. Similarly the contractor shall ensure that the bench marks, reference points, etc., which are marked out either with the help of Engineer-in-Charge or by the Engineer-in-Charge shall not be disturbed in any way during the performance of his works. If any work is to be performed which disturb such references, the same shall be done only after these are transferred to other suitable locations under the direction of the Engineer-in-Charge. The contractor shall provide all necessary materials and assistance for such relocation of reference points etc.

31.0 WORK AND SAFETY REGULATIONS

31.1 The contractor shall ensure proper safety of all the workmen, materials plant and equipment belonging to him or the Company or to others, working at or near the site. The contractor shall also be responsible for provision of all safety notices and safety equipment required both by the relevant legislation and the engineer-in-charge as he may deem necessary.

31.2 The contractor will notify well in advance to the engineer -in-charge of his intention to bring to the site any container filled with liquid or gaseous fuel or explosive or petroleum substance or such chemicals which may involve hazards. The engineer-in-charge shall have the right to prescribe the conditions, under which such container is to be stored, handled and used during the performance of the works and the contractor shall strictly adhere to and comply with such instructions. The engineer-in -charge shall have the right at his sole discretion to inspect any such container or such construction plant/equipment for which material in the container is required to be used and if in his opinion, its use is not safe, he

may forbid its' use. No claim due to such prohibition shall be entertained by the owner. Nor the owner shall entertain any claim of the contractor towards additional safety provisions/conditions to be provided for constructed as per engineer-in - charge's instructions.

Further any such decision of engineer-in-charge shall not, in any way,absolve the contractor of his responsibilities, and in case, use of such a container or entry thereof into the site area is forbidden by engineer-in- charge, the contractor shall use alternative methods with the approval of engineer-in-charge without any cost implication to Company or extension of work schedule.

- 31.3** Where it is necessary to provide and/or store petroleum products or petroleum mixtures and explosives, the contractor shall be responsible for carrying out such provision and/or storage in accordance with the rules and regulations laid down in Petroleum Act 1934, Explosives Act 1948, and Petroleum and Carbide of Calcium Manual Published by the Chief Inspector of Explosives of India. All such storage shall have prior approval of the engineer -in-charge. In case, any approvals are necessary from the Chief Inspector (Explosive) or any statutory authorities, the contractor shall be responsible for obtaining the same.
- 31.4** All equipment used in construction and erection by contractor shall meet Indian, International Standards and where such standards do not exist, the contractor shall ensure these to be absolutely safe. All equipment shall be strictly operated and maintained by the contractor in accordance with manufacturer's operation manual and safety instructions and as per Guidelines/Rules of the Company in this regard.
- 31.5** Periodical Examinations and all tests for all lifting/hoisting equipment and tackles shall be carried out in accordance with the relevant provisions of Factories Act 1948, Indian Electricity Act 1910 and associated Laws/Rules enforced from time to time. A register of such examinations and tests shall be properly maintained by the contractor and will be promptly produced as and when desired by engineer -in- charge or by the person authorized by him.
- 31.6** The contract shall be fully responsible for the safe storage of his and his sub-contractor's radio- active sources in accordance with BARC/DAE Rules and other applicable provisions. All precautionary measures stipulated by BARC/DAE in connection with use, storage and handling of such material will be taken by contractor.
- 31.7** The contractor shall provide suitable safety equipment of prescribed standard to all employee and workmen according to the need, as may be directed by engineer-in-charge who will also have right to examine these safety equipment to determine their suitability, reliability, acceptability and adaptability.
- 31.8** Where explosives are to be used, the same shall be used under the direct control and supervision of an expert, experienced, qualified and competent person strictly in accordance with the code practices/rules framed under Indian Explosives Act pertaining to handling, storage and use of the explosives.
- 31.9** The contractor shall provide safe working conditions to all workmen and employees at the site including safe means of access, railings, stairs, ladders, scaffoldings etc. The scaffoldings, stairs, ladders etc. shall be erected under the control and supervision of an experienced and competent person. For erection, good and standard quality of material only shall be used by the contractor.

- 31.10** The contractor shall not interfere or disturb electric fuses, wiring and other electrical equipment belonging to the owner or other contractors under any circumstances, whatsoever, unless expressly permitted in writing by the Company to handle such fuses, wiring or electrical equipment.
- 31.11** Before the contractor connects any electrical appliances to any plug or socket belonging to the other contractor or owner, he shall:
- a.** satisfy the Engineer-in-Charge that the appliances is in goodworking condition
 - b.** inform the Engineer-in-Charge of the maximum current rating,voltage and phases of the appliances.
 - c.** obtain permission of the Engineer-in-Charge detailing the socketsto which the appliances may be connected.
- 31.12** The Engineer-in-Charge will not grant permission to connect until he is satisfied that:
- a.** the appliance is in good condition and is fitted with a suitable plug.
 - b.** the appliance is fitted with a suitable cable having two earth conductors, one of which shall be an earthed metal sheath surrounding the cores.
- 31.13** No electric cable in use by the contractor/owner will be disturbed without prior permission. No weight of any description will be imposed on any cable and no ladder or similar equipment will rest against or attached to it.
- 31.14** No repair work shall be carried out on any live equipment. The equipment shall must be declared safe by engineer-in-charge and a permit to work shall be issued by engineer-in-charge before any repair work is carried out by the contractor. While working on electric lines/ equipment whether alive or dead, suitable type and sufficient quantity of tools will have to be provided by contractor to electricians/workmen/officers.
- 31.15** The contractor shall employ necessary number of qualified, full time electricians/electrical supervisors to maintain in his temporary electrical installations.
- 31.16** The contractor employing more than 250 workmen whether temporary, casual, probationer, regular or permanent or on contract, shall employ at least one full time officer exclusively as safety officer to supervise safety aspects of the equipment and workmen who will co-ordinate with the projectsafety officer. In case of work being carried out through sub-contractor's, the sub-contractor's workmen/employees will also be considered as the contractor's employees/workmen for above purpose. The name and address of a such safety officer of contractor will be promptly informed in writing to engineer-in -charge with a copy to safety officer-in charge before he starts work or immediately after any change of the incumbent is made during currency of the contract.
- 31.17** In case any accident occurs during the construction /erection or other associated activities undertaken by the contractor thereby causing any minor or major or fatal injury to his employees due to any reason, whatsoever, it shall be the responsibility of the contractor to promptly inform the same to the company's engineer-in-charge in prescribed form and also to all the authorities envisaged under the applicable laws.
- 31.18** The engineer -in-charge shall have the right at his sole discretion to stop the work, if in his opinion the work is being carried out in such a way that it may cause accidents and endanger

the safety of the persons and/or property, and/or equipment. In such cases, the contractor shall be informed in writing about the nature of hazards and possible injury/accident and he shall comply to remove short comings promptly. The contractor after stopping the specific work, can, if felt necessary, appeal against the order of stoppage of work to the General Manager of the project within 3 days of such stoppage of work and decision of the project G.M in this respect shall be conclusive and binding on the contractor.

31.19 The contractor shall not be entitled for any damages/compensation for stoppage of work due to safety reasons as provided in para 31.18 above and the period of such stoppage of work will not be taken as an extension of time for completion of work and will not be the ground for waiver of levy of liquidated damages.

31.20 The contractor shall follow and comply with all the Company safety rules relevant provisions of applicable laws pertaining to the safety of workmen, employees, plant and equipment as may be prescribed from time to time without demur, protest or content or reservation. In case of any inconformity between statutory requirement and the Company safety rules referred above, the later shall be binding on the contractor unless the statutory provisions are more stringent.

31.21 If the contractor fails in providing safe working environment as per the Company safety rules or continues the work even after being instructed to stop work by engineer -in-charge as provided in para 31.18 above, the contractor shall promptly pay to the Company, on demand i.e. by the owner compensation at the rate of Rs. 5,000/- per day or part thereof till the instructions are complied with and so certified by engineer-in-charge. However in case of accident taking place causing injury to any individual, the provisions contained in para 31.22 shall also apply in addition to compensation mentioned in this para.

31.22 If the contractor does not take all safety precautions and/or fails to comply with the safety rules as prescribed by the Company or under the applicable laws for the safety of the equipment and plant and for the safety of personnel and the contractor does not prevent hazardous conditions which cause injury to his own employees or employees of other contractors, or the Company employees or any other person who are at site or adjacent thereto, the contractor shall be responsible for payment of compensation under the relevant provisions of the workmen's compensation act and rules framed thereunder or any other applicable laws as applicable from time to time.

Permanent disablement shall have same meaning as indicated in workmen's compensation act. The compensation mentioned above shall be in addition to the compensation payable to the workmen/employees under the relevant provisions of the workmen's compensation act and rules framed thereunder or any other applicable laws as applicable from time to time.

In case the owner is made to pay such compensation then the contractor is liable to reimburse the owner such amount.

32.0 CODE REQUIREMENTS

The erection requirements and procedures to be followed during the installation of the equipment shall be in accordance with the relevant Indian Standard codes of practice or in their absence appropriate International Standard, Indian Boiler Regulations, ASME codes and accepted good engineering practice, the Engineer-in-Charge's drawings and other applicable Indian recognized codes and the laws and regulations of the Government of India.

33.0 FOUNDATION DRESSING AND GROUTING

33.1 The surfaces of foundations shall be dressed to bring the top surface of the foundations to the required level, prior to placement of equipment/equipment bases on the foundations.

33.2 All the equipment bases and structural steel base plates shall be grouted and finished as per these specifications unless otherwise recommended by the equipment manufacturer.

33.3 The concrete foundation surfaces shall be properly prepared by chipping, grinding as required to bring the type of such foundation to the required level, to provide the necessary roughness for bondage and to assure enough bearing strength. All laitance and surface film shall be removed and cleaned.

33.4 GROUTING MIX

The grouting mixtures shall be composed of Portland cement, sand and water. The Portland cement to be used shall conform to ISI No. 269 or equivalent, sand shall conform to ISI No. 383/2386 or equivalent. The grout proportions for flat based where the grouting space does not exceed 35mm shall be 50 Kg bag of cement to 75 Kg of sand. Only the required quantity of water shall be added so as to make the mix quaky and flow able and the mix shall not show excess water on top when it is being puddled in place. For thicker grout beds upto 65 mm, the amount of sand shall be increased to 105 Kg per bag of cement. Bases which are hollow and are to be filed full of grouting shall be filled to a level of 25 mm above the outside rim with a mortar mix in the volumetric proportions of one bag of cement and 1.5 bags sand and 1.5 part 6 mm granite gravel. An acceptable plasticiser may be added to the grout mixes in a proportion recommended by the plasticisers manufacturer. All such grouts shall be thoroughly mixed for not less than five minutes in an approved mechanical mixer and shall be used immediately after mixing.

33.5 PLACING OF GROUT

33.5.1 After the base has been prepared, its alignment and level has been checked and approved and before actually placing the grout a low dam shall be set around the base at a distance that will permit pouring and manipulation of the grout. The height of such dam shall be at least 25 mm above the bottom of the base. Suitable size and number of chains shall be introduced under the base before placing the grout, so that such chains can be moved back and forth to push the grout into every part of the space under the base.

33.5.2 The grout shall be poured either through grout holes if provided or shall be poured at one side or at two adjacent sides giving it a pressure head to make the grout move in a solid mass under the base and out in the opposite side. Pouring shall be continued until the entire space below the base is thoroughly filled and the grout stands at least 25 mm higher all around than the bottom of the base. Enough care should be taken to avoid any air or water pockets beneath the bases.

33.6 FINISHING OF THE EDGES OF THE GROUT

The poured grout should be allowed to stand undisturbed until it is well set. Immediately thereafter, the dam shall be removed and grout which extends beyond the edges of the structural or equipment base plates shall be cut off flush and removed. The edges of the grout

shall then be pointed and finished with 1:2 cement mortar pressed firmly to bond with the body of the grout and smoothed with a tool to present a smooth vertical surface. The work shall be done in a clean and scientific manner and the adjacent floor spaces, exposed edges of the foundations, and structural steel and equipment base plates shall be thoroughly cleaned of any spillage of the grout.

33.7 CHECKING OF EQUIPMENT AFTER GROUTING

After the grout is set and cured, the contractor shall check and verify the alignment of equipment, alignment of shafts of rotating machinery, the slopes of all bearing pedestals, centering of rotors with respect to their sealing bores, couplings, etc. as applicable and the like items to ensure that no displacement had taken place during grouting. The values recorded prior to grouting shall be used during such post grouting check-up and verifications. Such pre and post grout records of alignment details shall be maintained by the contractor in a manner acceptable to the Engineer-in-Charge.

34.0 SHAFT ALIGNMENTS

All the shafts of rotating equipment shall be properly aligned to those of the matching equipment to as perfect an accuracy as practicable. The equipment shall be free from excessive vibration so as to avoid over-heating of bearings or other conditions which may tend to shorten the life of the equipment. All bearings, shafts and other rotating parts shall be thoroughly cleaned and suitably lubricated before starting. All alignment should be checked through alignment checker or condition monitoring equipment in the presence of the engineer-in-charge.

35.0 DOWELING

All the motors and other equipment shall be suitably doweled after alignment of shafts with tapered machined dowels as per the direction of the Engineer-in-Charge.

36.0 CHECK OUT OF CONTROL SYSTEMS / POWER SUPPLY

After completion of wiring, cabling furnished under separate specifications and laid and terminated by the owner, the contractor shall check out the operation of all control systems for the equipment furnished and installed under these specifications and documents. The contractor shall get the drawings pertaining to the control system, power supply etc. approved from Directorate General of Mine Safety (DGMS) or any other appropriate authority as necessary, wherever required as per the rules and regulations of the Indian Mines Act governed by D.G.M.S.

37.0 COMMISSIONING SPARES

The contractor shall make arrangement for an adequate inventory at site of necessary commissioning spares prior to commissioning of the equipment furnished and erected so that any damage or loss during these commissioning activities necessitating the requirements of spares will not come in the way of timely completion of the works under the contract.

38.0 CABLING

38.1 All cables shall be supported by conduits or cable tray run in air or in cable channels. These shall be installed in exposed runs parallel or perpendicular to dominant surfaces with right angle turn made of symmetrical bends or fittings. When cables are run on cable trays, they

- shall be clamped at a minimum interval of 2000 mm or otherwise as directed by the Engineer-in-Charge.
- 38.2** Each cable, whether power or control, shall be provided with a metallic or plastic of an approved type, bearing a cable reference number indicated in the cable and conduit list (prepared by the contractor), at every 5 meter run or part thereof and at both ends of the cable adjacent to the terminations. Cable routing is to be done in such a way that cables are accessible for any maintenance and for easy identification.
- 38.3** Sharp bending and kinking of cables shall be avoided. The minimum radii for PVC insulated cables 1100 V grade shall be $15D$, where D is the overall diameter of the cable. Installation of other cables like high voltage, coaxial, screened, compensating, mineral insulated shall be in accordance with the cable manufacturer's recommendations. Wherever cables cross roads and water, oil, sewage or gas lines, special care should be taken for the protection of the cables in designing the cable channels.
- 38.4** In each cable run some extra length shall be kept at a suitable point to enable one to two straight through joints to be made should the cable develop fault at a later date.
- 38.5** Control cable terminations shall be made in accordance with wiring diagrams, using identifying codes subject to Engineer-in-Charge's approval. Multicore control cable jackets shall be removed as required to train and terminate the conductors. The cable jacket shall be left on the cable, as far as possible, to the point of the first conductor branch. The insulated conductors from which the jacket is removed shall be neatly twined in bundles and terminated. The bundles shall be firmly but not tightly tied utilizing plastic or nylon ties or specially treated fungus protected cord made for this purpose. Control cable conductor insulation shall be securely and evenly cut.
- 38.6** The connectors for control cables shall be covered with a transparent insulating sleeve so as to prevent accidental contact with ground or adjacent terminals and shall preferably terminate Elmex terminals and washers. The insulating sleeve shall be fire resistant and shall be long enough to over-pass the conductor insulation. All control cables shall be fanned out and connection made to terminal blocks and test equipment for proper operation before cables are corded together.

SECTION - 6

SPECIAL CONDITIONS OF CONTRACT

Sec	Clause	Aspect	Specific Terms
--	--	Completion Schedule	<ul style="list-style-type: none"> The time of completion and Commissioning of the Plant is 365 days, i.e. 12 months from the date of commencement. The O&M Contract Period is for Five years from the COD of the project. After completion of Five years of the O&M period, the same may be extended on mutually-agreed terms between the Employer and the Contractor. The Contractor shall inform the Company at least thirty (30) days advanced written notice of the date on which it intends to synchronize the Project to the grid.
1	13,21	Supply of Modules and Inverters	<ul style="list-style-type: none"> The procurement of solar modules & solar inverters for the subject tender will be done from Class-I local suppliers only, wherein, a Class-I local supplier' means a supplier or service provider, whose goods, services or works offered for procurement, has local content equal to or more than 50%, as defined under the above said orders. <p>[WRT MINISTRY OF NEW & RENEWABLE ENERGY (MNRE) ORDER NO 283/22/2019-GRID SOLAR DATED 23RD SEP 2020 FOR THE PUBLIC PROCUREMENT (PREFERENCETO MAKE IN INDIA) INCLUDING ANY AMENDMENTS, TO PROVIDE FOR PURCHASE PREFERENCE (LINKED WITH LOCAL CONTENT) IN RESPECT OF RENEWABLE ENERGY(RE) SECTOR]</p>
		Basic Custom Duty (BCD)	<p>Ministry of New & Renewable Energy (MNRE) vide OM NO 283/3/2018-GRID SOLAR DATED 09.03.2021 has notified the imposition of Basic Customs Duty (BCD) on solarPV modules & cells with effect from 01.04.2022. Post this date solar modules will attract BCD @ 40% & solar cells will attract BCD @ 25%. Thus, as on date 40% BCD will be applicable for Solar Modules. The estimate for this tender has been prepared considering the BCD impact and the bidder must quote their price accordingly.</p>
2	15	Delay in Execution or Failure to Supply	<ul style="list-style-type: none"> Any delay in completion of the work shall attract liquidated damage/ penalty for late completion.

Sec	Clause	Aspect	Specific Terms
			<ul style="list-style-type: none"> • If the Contractor fails to deliver the plant or fails to start the work within specified time frame after issue of LOA or fails to carry out the work as per agreed schedule or leaves the work site after partial execution of the work, the Company shall have the right to get the work done through any other agency at the risk and cost of the Contractor. Further to this, the Company may, without prejudice to the right of the Contractor to recover damages for breach of trust of the Contract, may impose penalties. • Notwithstanding anything contained in this tender document, bidders to note that the Completion time of the Project is the essence of the Contract. It is envisaged that the Contractor shall plan and achieve progress of the Project on or before the prescribed timeline/schedule without fail. • If, at any time, the Contractor's actual progress falls behind or is likely to fall behind the agreed schedule of the break-up/detailed Project activities, the Contractor shall submit to the Engineer-in-Charge, a revised program with catch up schedule, taking into account the prevailing circumstances and delay in the respective activities / milestones. The Contractor shall, at the same time/forthwith notify promptly to the Engineer-in-Charge of the steps being taken to expedite progress of the Project activities, so as to achieve completion of such activities within the agreed Time schedule for Completion. The Contractor shall in order to overcome the situation, forthwith mobilize required additional resources like manpower, materials, machineries etc. to achieve the prescribed timeline/schedule at his risk and cost. • In case further slippage is observed in the progress of Project activities, as per agreed time schedule or failure by the Contractor, at any stage of the Contract, to perform the Contract diligently to fulfil his obligations as per the Contract, the Company reserves the right to engage any other Contractor(s)/sub-contractor(s) at any time, at the risk and cost of the original Contractor to ensure completion of the Project activities in line with the agreed time schedule.

Section	Clause	Aspect	Specific Terms
2 4	15, 16 3.2	Liquidated Damages for Delay and Underperformance	<p>A. Delay in Commissioning and COD</p> <ul style="list-style-type: none"> • In case the Contractor fails to achieve successful Commissioning/ COD of the Project within 365 days (i.e. 12 months) from the date of commencement, then the Company shall levy the Liquidated Damages on the Contractor. Part commissioning shall be allowed with minimum allowed part capacity being 17.5 MW(AC). However, Performance Guarantee Test and O&M period shall start only when the full capacity of 20 MW (AC)/47.25 MW(DC) will be commissioned by the Contractor. • Completion time is the essence of the Contract and the same shall be firm and binding. For calculation of Liquidated Damages (LD), Project schedule shall be considered as 365 Days (i.e. 12 months) i.e. project shall be completed (COD with full capacity) within 365 Days (i.e. 12 months) from the Zero Date (The Zero Date will be counted from the 30th day from the issue of LoA / Work Order). • In case the EPC Works of solar PV project (COD with full capacity) is not completed within the stipulated time period and the delay is due to reason attributable to the Contractor, then the Contractor shall pay to the Company compensation for delay subject to following: <ul style="list-style-type: none"> ○ Delay up to 30 days: Amount of INR 20,000/MW/Day shall be deducted as penalty for the first 30 days of delay, calculated on per day basis and proportionate to the capacity not commissioned as on COD. ○ Delay of more than 30 days and up to 60 days: Amount of INR 30,000/MW/day shall be deducted on per day basis and proportionate to the capacity not commissioned as on COD. ○ Delay of more than 60 days: Amount of INR 45,000 /MW/day shall be deducted on per day basis and proportionate to the capacity not commissioned as on COD. ○ For delay of more than 180 days from the scheduled commissioning date will cause the Contractor's Event of Default to occur.

Sec	Clause	Aspect	Specific Terms
			<ul style="list-style-type: none"> • The said right of the Bharat Coking Coal Limited to levy damages on account of delay shall be without prejudice to and in addition to the right of the Company to get the concerned work done from a third party at the complete risk and cost of the Contractor. • The Contractor shall indicate duration of all the activities in activity chart in conformity with the overall schedule of the completion of project. The Contractor shall submit the activity chart in the form of Bar Chart which shall be discussed and finalized and shall be a part of Contract. • Any strike / lockouts at works or site of the Contractor or his sub-supplier/sub-contractor shall not be considered as force majeure condition. • For calculation of penalty, Zero date or date of commencement shall be the reference date. <p>B. Underperformance</p> <ul style="list-style-type: none"> • For each Contract Year, the Contractor shall demonstrate “Actual Energy Delivered” at the Metering Point as compared to the quoted NEEGG. • If for any Contract Year, it is found that the “Actual Energy Delivered” is less than the quoted NEEGG for the particular year, the Contractor shall pay the compensation to the Company equivalent to INR (prevailing energy charge rate in INR/kWh payable by Bharat Coking Coal Limited to the DISCOM x 1.5) per kWh of under-generation. • The same shall be recovered from payment yet to be made by the Company to the Contractor and/ or from the Security deposit available with the Company. • This compensation shall not be applicable in events of Force Majeure identified under this Tender affecting supply of solar energy from the Project. <p>Maximum applicable Liquidated Damages: The upper ceiling for total liquidated damages shall be maximum 10% of the total Contract Price.</p>

Sec	Clause	Aspect	Specific Terms
2	19	Documents for Extension of Time request	<p>The following documents shall form the principal basis for consideration of Extension of Time with or without LD, levy of Liquidated Damages and settlement of extra claims during the execution of contract:</p> <ol style="list-style-type: none"> 1. The joint recordings in “Hindrance Register” and “Weekly Review Register”. 2. Records of Technical Coordination Meetings. 3. Records of Contract Review Meetings, 4. Written notices issued by the “Engineer-in-Charge” or his authorized Representative to the Contractor in the relevant period. "
2	17	Force Majeure	<p>A ‘Force Majeure’ (FM) would mean one or more of the following acts, events or circumstances or a combination of acts, events or circumstances or the consequence(s) thereof, that wholly or partly prevents or unavoidably delays the performance by the Party (the Affected Party) of its obligations under the contract agreement, but only if and to the extent that such events or circumstances are not within the reasonable control, directly or indirectly, of the Affected Party and could not have been avoided if the Affected Party had taken reasonable care or complied with Prudent Utility Practices. An Affected Party means Bharat Coking Coal Limited or the Contractor whose performance has been affected by an event of Force Majeure.</p> <p>Categorization of Force Majeure Events:</p> <ol style="list-style-type: none"> a) Act of God, including, but not limited to lightning, drought, fire and explosion (to the extent originating from a source external to the site), earthquake, volcanic eruption, landslide, flood, cyclone, typhoon or tornado if and only if it is declared / notified by the competent state / central authority / agency (as applicable); b) any act of war (whether declared or undeclared), invasion, armed conflict or act of foreign enemy, blockade, embargo, revolution, riot, insurrection, terrorist or military action if and only if it is declared / notified by the competent state / central authority / agency (as applicable); or c) radioactive contamination or ionizing radiation originating from a source in India or resulting from another Force Majeure Event mentioned above

Sec	Clause	Aspect	Specific Terms
			<p>excluding circumstances where the source or cause of contamination or radiation is brought or has been brought into or near the Power Project by the Affected Party or those employed or engaged by the Affected Party.</p> <p>Force Majeure Exclusions: Force Majeure shall not include (i) any event or circumstance which is within the reasonable control of the Parties and (ii) the following conditions, except to the extent that they are consequences of an event of Force Majeure:</p> <ul style="list-style-type: none"> a. Unavailability, Late Delivery or Change in cost of plants and machineries, equipment, materials, spares parts or consumables for the project; b. Delay in performance of the Contractor or its sub-contractor or their agents; c. Nonperformance resulting from normal wear and tear experience in power generation materials and equipment's; d. Strike or Labor Disturbances at the facilities of affected parties; e. Insufficiency of finances or funds or the agreement becoming onerous to perform, and f. Non-performance caused by, or concerned with, the affected party's <ul style="list-style-type: none"> i. Negligent and intentional acts, errors or omissions; ii. Failure to comply with Indian law or Indian Directive; or iii. Breach of, or default under this agreement <p>Notification of Force Majeure Event</p> <ul style="list-style-type: none"> a. The affected Party shall give notice to other party of any event of Force Majeure as soon as reasonably practicable, but not later than 7 days after the date on which such Party knew or should reasonably have known of the commencement of the event of Force Majeure. If any event of Force Majeure results in a breakdown of communication rendering it not reasonable to give notice within the applicable time limit specified herein, then the party claiming Force Majeure shall give such notice as soon as reasonably practicable after reinstatement of communication, but not later than one day after such reinstatement.

Sec	Clause	Aspect	Specific Terms
			<p>b. Provided that such notice shall be a pre-condition to the Affected Party's entitlement to claim relief under the contract. Such notice shall include full particulars of the event of Force Majeure, its effects on the Party claiming relief and the remedial measures proposed. The Affected Party shall give the other Party regular (and not less than weekly) reports on the progress of those remedial measures and such other information as the other Party may reasonably request about the Force Majeure Event. The affected Party shall give notice to the other Party of (1) cessation of relevant event of Force Majeure; and (2) cessation of the effects of such event of Force Majeure on the performance of its rights or obligations under this agreement, as soon as practicable after becoming aware of each of these cessations.</p> <p>Performance Excused:</p> <p>a. The Affected Party, to the extent rendered unable to perform its obligations or part of the obligation thereof under the contract as a consequence of the Force Majeure Event, shall be excused from performance of the obligations, provided that the period shall not exceed 180 (one hundred and eighty) Days from the date of issuance of the FM Notice. The Parties may mutually agree to extend the period for which performance is excused due to a Force Majeure Event.</p> <p>b. For the time period, as mutually agreed by the Parties, during which the performance shall be excused, the contractor shall be entitled for a day to day extension of the period provided for the scheduled COD or the O&M period, as the case may be.</p> <p>c. Provided always that a Party shall be excused from performance only to the extent reasonably warranted by the Force Majeure Event.</p> <p>Provided further that, nothing shall absolve the Affected Party from any payment obligations accrued prior to the occurrence of the underlying Force Majeure Event.</p>

Sec	Clause	Aspect	Specific Terms
			<p data-bbox="521 254 902 281">No Liability for Other Losses</p> <p data-bbox="521 321 1495 420">a. Save as otherwise provided in this Agreement, no Party shall be liable in any manner, whatsoever, to the other Parties in respect of any loss relating to or arising out of the occurrence or existence of any Force Majeure Event.</p> <p data-bbox="521 438 873 466">Resumption of Performance</p> <p data-bbox="521 472 1484 701">During the period that a Force Majeure Event is subsisting, the Affected Party shall, in consultation with the other Parties, make all reasonable efforts to limit or mitigate the effects of such Force Majeure Event on the performance of its obligations under the contract. The Affected Party shall also make efforts to resume performance of its obligations under this Agreement as soon as possible and upon resumption, shall notify other Parties of the same in writing. The other Parties shall afford all reasonable assistance to the Affected Party in this regard.</p> <p data-bbox="521 720 995 747">Duty to Perform and Duty to Mitigate</p> <p data-bbox="521 753 1484 884">To the extent not prevented by a Force Majeure Event, the Affected Party shall continue to perform its obligations pursuant to this Agreement, the Affected Party shall use its reasonable efforts to mitigate the effect of any Force Majeure Event as soon as practicable.</p> <p data-bbox="521 924 1300 951">Available Relief and Termination Due to Force Majeure Event</p> <p data-bbox="537 991 1484 1287">a. If, prior to the completion of the 180 (one hundred and eighty) Day period (or any extended period) for a Force Majeure Event commencing from the date of issuance of the Force Majeure Notice, the Parties are of the reasonable view that a Force Majeure Event is likely to continue beyond such 180 (one hundred and eighty) Day period or any extended period agreed in pursuance of the clause ‘Performance Excused’; or that it is uneconomic or impractical to restore the affected Unit, then the Parties may mutually decide to terminate the contract, and the termination shall take effect from the date on which such decision is taken.</p> <p data-bbox="537 1306 1484 1373">b. The Affected Party shall, after the expiry of the period of 180 (one hundred and eighty) Days or any other mutually extended period, be entitled to</p>

Sec	Clause	Aspect	Specific Terms
			<p>Forth with terminate the contract in its sole discretion by issuing a notice to that effect.</p> <p>c. On termination of the contract</p> <p>i. no Termination Compensation shall be payable to the Contractor.</p> <p>ii. the Contractor shall be eligible for undisputed payments under outstanding Monthly Bill(s), before the occurrence of Force Majeure Event</p>
2	16, 18	Event of Default	<p>Contractor's Default: The occurrence and/or continuation of any of the following events, unless any such event occurs as a result of a Force Majeure Event or a breach by imp of its obligations under this Agreement, shall constitute a Contractor Event of Default:</p> <p>(i) the failure to commence supply of power up to the Contracted Capacity, by the end of the period specified in Section-6 Special Conditions of Contract of this tender, or failure to continue supply of Contracted Capacity after COD throughout the O&M period, or</p> <p>if</p> <p>a) the Contractor assigns, mortgages or charges or purports to assign, mortgage or charge any of its assets or obligations related to the EPC contract for this solar Power Project in contravention of the provisions of this Agreement; or</p> <p>b) the Contractor transfers or novates any of its rights and / or obligations under this agreement, in a manner contrary to the provisions of this Agreement; except where such transfer</p>

Sec	Clause	Aspect	Specific Terms
			<ul style="list-style-type: none"> • is in pursuance of a Law; and does not affect the ability of the transferee to perform, and such transferee has the financial capability to perform, its obligations under this Agreement or • is to a transferee who assumes such obligations under this Agreement and the Agreement remains effective with respect to the transferee; (ii) if (a) the contractor becomes voluntarily or involuntarily the subject of any bankruptcy or insolvency or winding up proceedings and such proceedings remain uncontested for a period of thirty (30) days, or (b) any winding up or bankruptcy or insolvency order is passed against the contractor, or (c) the contractor goes into liquidation or dissolution or has a receiver or any similar officer appointed over all or substantially all of its assets or official liquidator is appointed to manage its affairs, pursuant to Law, provided that a dissolution or liquidation of the contractor will not be a contractor Event of Default if such dissolution or liquidation is for the purpose of a merger, consolidation or reorganization and where the resulting company retains creditworthiness similar to the contractor and expressly assumes all obligations of the contractor under this Agreement and is in a position to perform them; or (iii) the contractor repudiates this Agreement and does not rectify such breach within a period of thirty (30) days from a notice from Bharat Coking Coal Limited in this regard; or (iv) except where due to any CIL/Subsidiary's failure to comply with its material obligations, the contractor is in breach of any of its material obligations pursuant to this Agreement, and such material breach is not rectified by the Contractor within thirty (30) days of receipt of first notice in this regard given by Bharat Coking Coal Limited.

Sec	Clause	Aspect	Specific Terms
			<p>(v) Occurrence of any other event which is specified in this Agreement to be a material breach/ default of the contractor.</p> <p>(vi) Failure or refusal by the Contractor to perform any of it's material obligations under this contract</p> <ul style="list-style-type: none"> • Company's Default: The occurrence and the continuation of any of the following events, unless any such event occurs as a result of a Force Majeure Event or a breach by the contractor of its obligations under this Agreement, shall constitute the Event of Default on the part of defaulting Company: <ul style="list-style-type: none"> (i) The Company fails to pay (with respect to a Monthly Bill or a Supplementary Bill), for a period of ninety (90) days after the Due Date and the contractor is unable to recover the amount outstanding to the contractor through the Letter of Credit, (ii) The Company repudiates this Agreement and does not rectify such breach even within a period of sixty (60) days from a notice from the Contractor in this regard; or (iii) except where due to any Contractor's failure to comply with its obligations, The Company is in material breach of any of its obligations pursuant to this Agreement, and such material breach is not rectified by the Company within sixty (60) days of receipt of notice in this regard from the Contractor to Company; or if <ul style="list-style-type: none"> • The company becomes voluntarily or involuntarily the subject of any bankruptcy or insolvency or winding up proceedings and such proceedings remain uncontested for a period of sixty (60) days, or • any winding up or bankruptcy or insolvency order is passed against the Company, or • The Company goes into liquidation or dissolution or a receiver or any similar officer is appointed over all or substantially all of its assets or official liquidator is appointed to manage its affairs, pursuant to Law, provided that it shall not constitute a Company Event of Default, where such dissolution or liquidation of Buyer or Company is for the purpose of a merger, consolidation or reorganization and where the resulting entity has the financial standing to perform its obligations under this Agreement and has creditworthiness similar to Company and expressly

Sec	Clause	Aspect	Specific Terms
			<p>assumes all obligations of Company and is in a position to perform them; or;</p> <p>(iv) Occurrence of any other event which is specified in this Agreement to be a material breach or default of the Company.</p>
—	--		<p>Power Evacuation shall be through tie transformers at voltage level of corresponding STU substation, which shall be identified by bidder according to the location of solar plant. Supply and installation of metering panel along with control cable shall be in bidder's scope. ABT metering arrangement at STU substation ends shall be as per STU requirement/standard. The system design and redundancy/capacity margin in EHV Power Transformer should be such that even during outage of one power Transformer, power equivalent to 70% of project capacity can be evacuated at any time to STU Grid from Main pooling MV switchgear. In case bidder supply same power transformer as common mandatory spare which can be used as one to one replacement of transformers in service, then it shall also be accounted as redundancy. Bidder can adopt any of the following criteria or better for EHV powertransformers:</p> <ul style="list-style-type: none"> A. 1x100% + 1 spare of equivalent capacity B. 2x50% + 1 spare of equivalent capacity C. 2x75% D. 3x35 % (Min) or with higher number of transformer combinations. <p>(To ensure availability of minimum 70% capacity in case of the outage of one of the transformers)</p> <p>If the bay execution work is not carried out by STU, it shall be the responsibility of bidder for the execution of bay work along with complete integration with STU system following the applicable standards/latest Technical Standard for Construction of Substation and Switchyard published by CEA, data communication etc. as per requirement. All charges payable for the bay related works and co-Ordination with STU/SLDC shall be in bidder's scope. The coordination works,</p>

Sec	Clause	Aspect	Specific Terms
			<p>Interface systems, software/hardware, data integration, telemetry data, RLDC/SLDC/CEA/STU requirements etc. as required for completeness of project commissioning are included in bidder's scope. The capacity of transmission system from solar plant to STU substation shall comply with connectivity regulations and procedures. All equipment/hardware required for termination as well as equipment support structure and civil works for completing the connectivity of the system up to interconnection point is in the scope of the bidder.</p> <p>Bidder can evacuate the power using single circuit or multi-circuit configuration (complying with connectivity regulations) and bid evaluation shall be done as indicated in the evaluation criteria.</p>
2	19.2	Hindrance Register	<ul style="list-style-type: none"> • Record of Hindrances / events that lead to slow/ stoppage of smooth execution of work shall be maintained in "Hindrance Register". • The Contractor shall maintain the Register where reasons for delay may be recorded from time to time and at the time of occurrence of the hindrance and get it duly certified by the Engineer-in-Charge of the Company or his authorized representative.
--	--	Handing Over	<ul style="list-style-type: none"> • After Commissioning of the Project by the Contractor, the Contractor to intimate the same to the Company and subsequently, appropriate authorities from the Company will check the Project as per terms and conditions of the Contract and will give punch points to the Contractor, which shall be attended by the Contractor. Further after commissioning, the Contractor shall submit the following to the Company: <ul style="list-style-type: none"> I. All as- Built Drawings; II. Detailed Engineering Document with detailed specification, schematic drawing, circuit drawing and test results, manuals for all deliverable items, Operation, Maintenance & Safety Instruction Manual and other information about the project; III. Bill of material; and

Sec	Clause	Aspect	Specific Terms
			<p>IV. Inventory of spares at projects Site.</p> <p>V. Copies of all warranties/guarantees.</p> <ul style="list-style-type: none"> • After Commissioning, the Contractor to perform Operation & Maintenance for a period as mentioned in the RFP document. • Prior to the completion of the O&M period, the Company shall conduct a plant audit by self or the third party as per the Company's discretion, and any defects identified during such audits or inspection shall be rectified by the Contractor at its own cost prior to handing over. • If the Employer is satisfied with the completion of O&M of Solar Photo Voltaic Project as the provisions of the Contract, the Employer shall issue to the Contractor a Taking Over Certificate as a proof of final acceptance of the entire Solar Photo Voltaic Project. Such certificate shall not relieve the Contractor of any of its obligation which otherwise survive, by the terms and conditions of the Contract after issuance of such certificate. • Upon successful fulfilment of all the obligation of the Contractor, the Employer shall require the Contractor to furnish a "No Demand Certificate" as per the format enclosed at Annexure-XVII. • The final closing of the contract shall be effected after the Defect Liability Period is successfully completed and the Performance Bank Guarantee (i.e. Security deposit) of the Contractor is returned/ discharged.
--	--	Change in Law	<ul style="list-style-type: none"> • The term Change in Law shall refer to the occurrence of any of the following events pertaining to this project only after last date of submission of this tender including (i) the enactment of any new law; or (ii) an amendment, modification or repeal of an existing law; or (iii) the requirement to obtain a new consent, permit or license; or (iv) any modification to the prevailing conditions prescribed for obtaining an consent, permit or license, not owing to any default of the contractor; or (v) any change in the rates of any Taxes including any duties and cess or introduction of any new tax made applicable for setting up the solar power project and supply of power from project which have a direct effect on the Project.

Sec	Clause	Aspect	Specific Terms
			<ul style="list-style-type: none"> • However, Change in Law shall not include (i) any change in taxes on corporate income or (ii) any change in any withholding tax on income or dividends distributed to the shareholders of the Contractor. • In the event of occurrence of any of events as provided under Article which results in any increase/ decrease in the Project Cost (i.e. the cost incurred by the Contractor towards supply and services only for the Project concerned, up to the Actual Commissioning Date of the last part capacity or Scheduled Commissioning Date/extended Scheduled Commissioning Date, whichever is earlier), the Contractor/ Company shall be entitled for compensation by the other party, as the case may be. • However, in case of change in rates of safeguard duty, GST and basic customs duty after last date of submission of this tender and resulting in change in Project Cost, then such change will be treated as ‘Change in Law’ and the quantum of compensation payment on account of change in rates of such duties and shall be provided to the affected party by the other party. • It is clarified that, any introduction of new tax/duty/cess made applicable for setting up the solar power project and supply of power from the Solar Power project by the Contractor which have a direct effect on the Project, resulting in change in Project Cost, will also qualify under “Change in Law” as per timeline and procedure indicated herein. • It is further clarified that, applicability of Safeguard Duty on “Solar Cells whether or not assembled in modules or panels” which is till 29.07.2021, if gets extended and has a direct effect on the Project, resulting in change in Project Cost, such extension will also qualify under “Change in Law” as per timeline and procedure indicated herein. <p>Notification of Change in Law</p> <ul style="list-style-type: none"> • In case of any decrease or increase in project cost occurs due to Change in Law and the Contractor wishes to claim a Change in Law under this Article, it shall give notice to the Bharat Coking Coal Limited of such Change in Law as

Sec	Clause	Aspect	Specific Terms
			<p>soon as reasonably practicable (but no later than 30 days from the date of occurrence of such Change in Law).</p> <ul style="list-style-type: none"> Any notice service shall provide, amongst other things, precise details of the Change in Law and its effect on the Project Cost, supported by documentary evidences including Statutory Auditor Certificate to this effect so as to establish one to one correlation and its impact on the Project Cost.
2	39	Progress Report of Work	<ul style="list-style-type: none"> The authorized representative of the Contractor shall review the progress of the Project work every fortnight on a prefixed day at project site with the Company or its representative as per the network and record the minutes. The Contractor shall submit a weekly progress report on execution of works conforming to bar/ PERT Chart and format provided by the Company. The Contractor shall be required to attend all weekly site progress review meetings organized by the 'Engineer-in-Charge' or his authorized representative. The deliberations in the meetings shall inter alia include the weekly program, progress of work (including details of manpower, tools and plants deployed by the contractor vis-a-vis agreed schedule), inputs to be provided by Employer, delays, if any, and recovery program, specific hindrances to work and work instructions by Employer. In case of any slippage(s) or delay in execution of work reasons for such delay along with details of hindrances will be submitted by the Contractor along with modified Bar/ PERT Chart mentioning the action plan being taken to keep the due date of completion of project unchanged. If required, the Contractor shall use additional manpower to keep the due date of completion of Project unchanged. The minutes of the weekly meetings shall be recorded in triplicate in a numbered register available with the 'Engineer-in-Charge', or his authorized representative. These recordings shall be jointly signed by the Engineer-in-Charge or his authorized representative and the Contractor and one copy of the signed records shall be handed over to the Contractor.
4	13	Inspection and Testing	<ul style="list-style-type: none"> The Company or its authorized representative including appointed Consultant for the project shall have, at all times, access to the Contractor's premises and also shall have the power to inspect and examine the materials and

Sec	Clause	Aspect	Specific Terms
5	4		<p>workmanship of project work during its manufacture, shop assembly and testing. If part of the plant is required to be manufactured in the premises other than the Contractor's, the necessary permission for inspection shall be obtained by the Contractor on behalf of the Company or its duly authorized representative.</p> <ul style="list-style-type: none"> • The Contractor shall offer following Test / Inspection to the Company: <ol style="list-style-type: none"> I. The Company may depute its Engineer or representative or hire an agency for Third-Party Inspection, for pre-dispatch inspection at the manufacturing facility of the Contractor all items under this RFP as per applicable standards, approved QAP and documents. Samples for testing shall be drawn randomly in presence of the Company/ inspecting agency from the lot offered for inspection. After Test/Inspection of the Items at factory, the Contractor is to submit the inspection & test reports to the Company for review. After review of the inspection & test reports, the Company will give dispatch clearance in writing. The Contractor shall not dispatch any item without dispatch clearance from the Company, in writing. II. The Company may depute its Engineer or representative or third party inspection agency for inspection during manufacture and in assembled condition prior to dispatch in accordance with the standard practice/ QAP of the manufacturer and applicable Standards, at no additional cost to the Company for demonstration and performing the test/inspection. The Contractor shall raise inspection call with internal test reports in advance for all items like PV Modules, MMS, cables, SJBs, Inverters, Transformers, HT & LT switchgears, DC system, Switchyard equipment, earthing system, SCADA, RMU etc. III. Upon delivery of the photovoltaic modules on site, they shall be sampled randomly and tested for performance through an approved testing agency assigned by the Company. The result of such testing agency shall be binding to both the parties and shall be considered final performance measurement report for the guarantee / warranty conditions of this contract.

Sec	Clause	Aspect	Specific Terms
			<ul style="list-style-type: none"> • In case of underperformance or rejection of the photovoltaic modules during above inspection or during operational lifetime of project, the Company shall notify the Contractor of such underperformance or rejection by email or in writing. <ol style="list-style-type: none"> I. Consecutively, the Contractor shall immediately replace such PV modules by supplying a new PV module of similar specification conforming to the required performance criteria and warranty to the Company within a period of 10 days from the date of intimation by email or written notice. II. Upon receipt of the new PV module, the Contractor shall arrange to collect the rejected/defective photovoltaic module from site. III. The cost of transportation of the PV modules from the supplier to the site of CIL/Subsidiary, and return shall be borne by the Contractor. • The Company shall have the right to serve notice in writing to the Contractor on any grounds of objections, which he may have in respect of the work. The Contractor has to satisfy the objection, otherwise, the Company at his liberty may reject all or any component of plant or workmanship connected with such work. • The Contractor shall issue request letter to the Company or his authorized representative for testing of any component of the plant, which is ready for testing at least fifteen (15) days in advance from the date of actual date of testing at the premises of the Contractor or elsewhere. When the inspection and the tests have been satisfactorily completed at the Contractor's works, the Company shall issue a certificate to that effect. However, the Owner at its own discretion may waive the inspection and testing in writing under very special circumstances. In such case, the Contractor may proceed with the tests which shall be deemed to have been made in the Company's presence, and it shall forthwith forward six (6) sets of duly certified copies of test results and certificates to the Company for approval of the Company. The Contractor, on receipt of written acceptance from the Company, may dispatch the equipment for erection and installation. • For all tests to be carried out, whether in the premises of the Contractor or any Subcontractor or the supplier, the Contractor, shall provide labor, materials,

Sec	Clause	Aspect	Specific Terms
			<p>electricity fuel, water, stores, apparatus and instruments etc. free of charge as may reasonably be demanded to carry out such tests of the plant in accordance with the Contract. The Contractor shall provide all facilities to the Company or its authorized representative to accomplish such testing.</p> <ul style="list-style-type: none"> • The Company or his authorized representative shall have the right to carry out inward inspection of the items on delivery at the Site and if the items have been found to be not in line with the approved specifications, shall have the liberty to reject the same. • If the Company desires, testing of any component(s) of the plant be carried out by an independent agency, the inspection fee, if any, shall be paid by the Owner. However, the Contractor shall render all necessary help to the Company whenever required free of charge. • The Contractor has to provide the necessary testing reports to the Company as and when required. • Neither the waiving of inspection nor acceptance after inspection by the Company shall, in anyway, absolve the Contractor of the responsibility of supplying the plant and equipment strictly in accordance with specification and drawings etc. • If any item is not found conforming to standards during test / inspection, the same shall be replaced / rectified by Contractor without any cost to the Company and shall be re-offered for inspection. • The work is subject to inspection at all times and at all places by the Company. The Contractor shall carry out all instructions given during inspection and shall ensure that the work is carried out according to the relevant codes of practice • Decision of the Company in regard to the quality of work and materials and performance to the specifications and drawings shall be final.
--	--	Authorized Test Centers	<ul style="list-style-type: none"> • The PV modules, inverters, transformers, panels, wires, etc. deployed in the power plants shall have valid test certificates for their qualification as per IEC/ BIS Standards by one of the reputed labs of the respective equipment

Sec	Clause	Aspect	Specific Terms																											
			(Preferably NABL Accredited Test Centers) in India. In case of module or other equipment for which such Test facilities may not exist in India, test certificates from reputed ILAC Member Labs abroad or from test reports as per industry best practices in India will be acceptable.																											
2	41.6	Terms of Payment	<ul style="list-style-type: none"> The Owner shall pay the Contractor in the following manner. The Tender is a comprehensive EPC Contract of Supply, Works, Land and O&M. The payment schedules are given below. <p>Schedule of payment for Supply:</p> <table border="1"> <tr> <td>1</td> <td>Submission of Report on Land survey, Transmission Route survey, Soil test, Site selection Submission of Design Basis Report and GA drawing</td> <td>5% of supply Price</td> </tr> <tr> <td>2</td> <td>Supply of MMS on Pro rata basis</td> <td>10% of supply Price</td> </tr> <tr> <td>3</td> <td>Supply of PV Modules at the Project Site on pro-rata basis</td> <td>60% of supply Price</td> </tr> <tr> <td>4</td> <td>Supply of BOS and other items on Pro Rata basis except SI No. 2 to 3 above.</td> <td>20% of supply Price</td> </tr> <tr> <td>5</td> <td>Supply of tools, tackles and measuring instruments</td> <td>5% of supply Price</td> </tr> </table> <p>➤ Note: Item SI No 5 is to be supplied at the time of commissioning of the plant.</p> <p>Schedule of payment for Works:</p> <table border="1"> <tr> <td>1</td> <td>Against monthly RA bills for the Works executed at site with respect to the milestones achieved as per the project schedule furnished by the Contractor</td> <td>75 % of Works Price</td> </tr> <tr> <td>2</td> <td>Upon Successful Commissioning of the entire Project</td> <td>15 % of Works Price</td> </tr> <tr> <td>3</td> <td>Upon Successful Performance Guarantee Test</td> <td>10 % of Works Price</td> </tr> </table> <p>Schedule of payment for Operation and Maintenance (O&M):</p> <table border="1"> <tr> <td>1</td> <td>On Monthly basis for Successful Operation and Maintenance of the Project throughout the O&M Period based on the "O&M Contract Price"</td> <td></td> </tr> </table>	1	Submission of Report on Land survey, Transmission Route survey, Soil test, Site selection Submission of Design Basis Report and GA drawing	5% of supply Price	2	Supply of MMS on Pro rata basis	10% of supply Price	3	Supply of PV Modules at the Project Site on pro-rata basis	60% of supply Price	4	Supply of BOS and other items on Pro Rata basis except SI No. 2 to 3 above.	20% of supply Price	5	Supply of tools, tackles and measuring instruments	5% of supply Price	1	Against monthly RA bills for the Works executed at site with respect to the milestones achieved as per the project schedule furnished by the Contractor	75 % of Works Price	2	Upon Successful Commissioning of the entire Project	15 % of Works Price	3	Upon Successful Performance Guarantee Test	10 % of Works Price	1	On Monthly basis for Successful Operation and Maintenance of the Project throughout the O&M Period based on the "O&M Contract Price"	
1	Submission of Report on Land survey, Transmission Route survey, Soil test, Site selection Submission of Design Basis Report and GA drawing	5% of supply Price																												
2	Supply of MMS on Pro rata basis	10% of supply Price																												
3	Supply of PV Modules at the Project Site on pro-rata basis	60% of supply Price																												
4	Supply of BOS and other items on Pro Rata basis except SI No. 2 to 3 above.	20% of supply Price																												
5	Supply of tools, tackles and measuring instruments	5% of supply Price																												
1	Against monthly RA bills for the Works executed at site with respect to the milestones achieved as per the project schedule furnished by the Contractor	75 % of Works Price																												
2	Upon Successful Commissioning of the entire Project	15 % of Works Price																												
3	Upon Successful Performance Guarantee Test	10 % of Works Price																												
1	On Monthly basis for Successful Operation and Maintenance of the Project throughout the O&M Period based on the "O&M Contract Price"																													

Sec	Clause	Aspect	Specific Terms
	41.6, SCC	Mobilization Advance (Optional)	<p>If contractor choose to opt for Mobilization Advance, a maximum of 10 % of the total contractvalue of work will be paid as mobilization advance subject to submission of Bank Guarantee equal to 110% of the advance amount. The mobilization advance shall be paid in two equal installments. Interest on mobilization advance will be charged at the rate of CIL’s borrowing rate under cash credit arrangement as on date of disbursement and to be compounded quarterly. The mobilization advance shall be recovered from the bills of the contractor from the submission of 2nd bill onwards @ 20% of the advance amount paid. However, the full amount of mobilization advance with interest will be recovered maximum within scheduled date of completion of commissioning as per agreement. The value of Bank Guarantee may be reduced to the extent such advance is recovered by the company subject to the conditions that the value of Bank Guarantee amount at any time is more than the recoverable outstanding advance. Bank Guarantee shall be irrevocable and from a Scheduled- Bank acceptable to the Company. Contractor will be required to submit satisfactory utilization Certificate for the earlier instalments. Part Bank Guarantee” (BGs) against the Mobilization Advance shall be taken in as many numbers as the proposed recovery instalments and shall beequivalent to 110% of the amount of each instalment. In case of “Machinery and Equipment advance”, insurance and hypothecation to the employer shall be ensured. In addition to the above, interest will be charged as per the aforesaid rate on mobilization advance in case the contract is terminated due to default of the contractor.</p> <p>[Schedule of payment of Mobilization Advance installments shall be given at the time of issuance of LOA]</p>
2	41.1, 41.2, 41.3, 4.4, 41.5	Payment Procedure	<p>Subject to any deduction which the Employer may be authorized to make under this Contract, and or to any additions or deductions provided for this Contract, the Contractor shall be entitled to payment as follows:</p> <p>I. All payments shall be made in Indian Rupees (INR), unless otherwise Specified in the LOA/Contract Agreement. All payment shall be made on the basis of actual measurement for the quantified items as per schedule of works.</p> <p>II. The Contractor shall submit the Tax Invoice for claim in three copies with relevant GST details and all supporting documents as per the Contract condition to the Employer. After due verification and recommendation, the Employer shall process verified bills for release of payment. Payments shall be released in 30 (Thirty) days by A/c payee cheque / RTGS/ NEFT or any other mode as communicated by the Employer from date of submission of clear invoice.</p> <p>III. The Contractor shall give complete shipping information concerning the weight, size, content of each package including any other information the Employer, may require.</p> <p>a. For offshore supplies by the Contractor, following documents shall be air-mailed to the Employer within (7) days from the date of shipment. The advance copy of these documents shall be sent through e-mail:</p>

			<ul style="list-style-type: none"> i. Insurance certificates (6 copies) ii. Bill of lading (5 non-negotiable copies) iii. Invoice (6 copies) iv. Packing list (6 copies) v. Test certificate (3 copies) vi. Certificate of Origin (six copies) vii. One copy of the packing list shall also be enclosed in each case. viii. O & M Manuals &/or Catalogues <p>b. For onshore supply, the following documents shall be submitted through registered post to the Employer within 3 days from the date of shipment, the advance copy of these documents shall be sent through e-mail.</p> <ul style="list-style-type: none"> i. Invoice (4 copies) ii. LR copies iii. Packing list (4 copies) iv. Test Certificate (3 copies) v. One copy of the packing list shall also be enclosed in each case. vi. O & M Manuals &/or Catalogues <p>IV. The Contractor shall submit the Tax Invoice for the work executed showing separately GST and any other statutory levies in the Tax Invoice.</p> <p>V. Any discrepancy and delay, which result in demurrage and other charges for the consignment (for incomplete/incorrect documentation) will be to the account of the Contractor. All the formalities for custom clearance are in the Contractor's scope.</p> <p>VI. All taxes and deductions shall be applicable as per prevailing statutory rules and provisions in force.</p> <p>VII. In case the Contractor fails to submit the invoice with all the required documents to process payments, the Employer reserves the right to hold the payment of the Contractor against such invoices.</p>
2	13, 33, 34	Warranty/ Guarantee	<ul style="list-style-type: none"> • The Plant shall perform as per the Guaranteed Performance indicated by the Bidder in its Bid. • PV modules used in grid connected solar power plants must be warranted for peak output wattage, which should not be less than 90% at the end of 10 years and 80% at the end of 25 years. • All plant equipment and components and overall workmanship of the grid solar power plants shall be warranted for a minimum of 5 years except solar PV Modules for which product warranty shall be for 10 years and performance warranty shall be for 25 years. • The Contractor shall ensure that the goods supplied under the Contract are new, unused and of most recent or current models and incorporate all recent improvements in design and materials unless provided otherwise in the Contract. • At the end of Contract period, the Contractor's liability shall cease. BCCL shall be entitled to the benefit of such warranty given to the

			<p>Contractor by the original contractor or manufacturer or supplier of such goods.</p> <ul style="list-style-type: none"> • During the Contract period, the Contractor shall be responsible for any defects in the work due to faulty workmanship or due to use of substandard materials in the work. Any defects in the work during the Contract period shall therefore, be rectified by the Contractor without any extra cost to BCCL within a reasonable time as may be considered from the date of receipt of such intimation from BCCL failing which BCCL shall take up rectification work at the risk and cost of the Contractor.
--	--	Project Management Consultant and Third-Party Inspection Agency	<ul style="list-style-type: none"> • A Project Management Consultancy (PMC) or Third-Party Inspection agency (TPI) may be appointed by the Company, at its sole discretion, to conduct any kind of inspection regarding procurement, fabrication, installation, hook-up, quality, execution, commissioning, operation and maintenance during the span of the Project. The Contractor shall provide necessary access and coordination to conduct such inspections. The Contractor shall provide all necessary access and cooperation for inspection by any National or State agency.
5	14.2, 14.3	Power and Water Supply during Construction	<ul style="list-style-type: none"> • The Contractor shall arrange for the temporary Power Supply at the site for construction purpose at its own cost. • Cost of water shall be as per prevailing rate and to be borne by the Contractor. Contractor has to arrange water. • Cost of electricity required during construction shall be payable by the Contractor. For construction, temporary connection from Distribution Company shall be arranged by the Contractor as per applicable tariff. • The Company shall not provide facility for storage of material, and accommodation for labors at site. The Contractor shall make his own arrangement for the same.
--	--	Shift Work	<ul style="list-style-type: none"> • To achieve the required rate of progress in order to complete the Facilities within the Time for Completion, the Contractor may carry on the work round the clock, in multiple shifts per day, as may be necessary. The Contractor shall however be responsible to comply with all applicable laws in this regard. • No additional payment will be made on account of round the clock working in multiple shifts. • Wherever the work is carried out at night adequate lighting of working areas and access routes for pedestrians or vehicles shall be provided by the Contractor at his cost. Sufficient notice should be given by the Contractor to the Employer regarding the details of works in shifts so that necessary supervision should be provided.
--	--	Transportation of Materials by Road	<ul style="list-style-type: none"> • In case, the Contractor decides to transport the Plant and Equipment and the Contractor's Equipment by road, then such Plant and Equipment and the Contractor's Equipment must necessarily be transported through a registered common carrier as per Carriage by Road Rules 2011 of Central Government of India.

--	--	Contractor's obligations	<ul style="list-style-type: none"> Subsequent to successful completion of Guarantee Test, the Contractor shall be responsible for completion of all pending obligations within the stipulated timelines as mentioned hereunder: <table border="1"> <thead> <tr> <th>S. No</th> <th>Contractor's Obligation</th> <th>Timelines</th> </tr> </thead> <tbody> <tr> <td>01</td> <td>Any inputs regarding Scope Change</td> <td>Within 01 month from the date of successful completion of Guarantee Test</td> </tr> <tr> <td>02</td> <td>Submission of pending Engineering Documents/Drawings including O&M Manuals.</td> <td>Within 01 month from the date of successful completion of Guarantee Test</td> </tr> <tr> <td>03</td> <td>Contractor's compliance to all the pending points recorded in writing by the Employer during Performance Guarantee Test.</td> <td>Within 01 month from the date of successful completion of Guarantee Test</td> </tr> <tr> <td>04</td> <td>Any other obligations of the Contractor set forth in the Contract</td> <td>Within 01 month from the date of successful completion of Guarantee Test.</td> </tr> </tbody> </table>	S. No	Contractor's Obligation	Timelines	01	Any inputs regarding Scope Change	Within 01 month from the date of successful completion of Guarantee Test	02	Submission of pending Engineering Documents/Drawings including O&M Manuals.	Within 01 month from the date of successful completion of Guarantee Test	03	Contractor's compliance to all the pending points recorded in writing by the Employer during Performance Guarantee Test.	Within 01 month from the date of successful completion of Guarantee Test	04	Any other obligations of the Contractor set forth in the Contract	Within 01 month from the date of successful completion of Guarantee Test.
S. No	Contractor's Obligation	Timelines																
01	Any inputs regarding Scope Change	Within 01 month from the date of successful completion of Guarantee Test																
02	Submission of pending Engineering Documents/Drawings including O&M Manuals.	Within 01 month from the date of successful completion of Guarantee Test																
03	Contractor's compliance to all the pending points recorded in writing by the Employer during Performance Guarantee Test.	Within 01 month from the date of successful completion of Guarantee Test																
04	Any other obligations of the Contractor set forth in the Contract	Within 01 month from the date of successful completion of Guarantee Test.																
--	--	Incentive for Surplus Generation	<ul style="list-style-type: none"> In case of surplus generation from the said solar PV plant after fulfilling the desired demand of BCCL, if the surplus energy generated is agreed to be consumed by the respective DISCOMs at a mutually agreed tariff, the selected EPC player will be eligible to receive an incentive for the same. However, the incentives will be provided as per a mutually agreed rate between the selected EPC player and BCCL. 															
2	1	Definitions	<ul style="list-style-type: none"> "Actual Energy Delivered" means the net energy in kilo-watt hour (kWh) from the Project as measured at the Metering Point at Grid/delivery point. "Applicable Law" means any statute, law, regulation, ordinance, notification, rule, regulation, judgment, order, decree, bye-law, approval, directive, guideline, policy, requirement or other governmental restriction or any similar form of decision of, or determination by, or any interpretation or administration having the force of law in the Republic of India and the State Government, by any Government Authority or instrumentality thereof, whether in effect as of the date of this Contract or thereafter. "Appropriate Commission" shall mean Dhanbad Electricity Regulatory Commission unless otherwise stated; 															

		<ul style="list-style-type: none"> • “Bid” shall mean the bid submitted by the Bidder in response to this Tender. • “Bidder” shall mean Bidding Company or a Bidding Individual submitting the Bid. Any reference to the Bidder includes Bidding Company / Bidding Individual including its successors, executors and permitted assigns severally, as the context may require; • “Capacity Utilization Factor (CUF)” shall have the same meaning as provided in CERC (Terms and Conditions for Tariff determination from Renewable Energy Sources) Regulations, 2009 as amended from time to time; However, for avoidance of any doubt, it is clarified that the CUF shall be calculated on the Contracted Capacity as per following formula: In any Contract Year, if ‘X’ MWh of energy has been metered out at the Delivery Point for ‘Y’ MW Project capacity, $CUF = (X \text{ MWh} / (Y \text{ MW} * 8766)) * 100\%$; “CERC” means Central Electricity Regulatory Commission. • “Change in Law” shall have the meaning ascribed thereto in this Tender document. • “Chartered Accountant” shall mean a person practicing in India or a firm whereof all the partners practicing in India as a Chartered Accountant(s) within the meaning of the Chartered Accountants Act, 1949. • "Commercial Operation Date (COD)" shall mean the date on which the commissioning certificate is issued upon successful commissioning (as per prevailing regulatory framework of the Appropriate Commission) of the full capacity of the project or the last part capacity of the Project as the case may be. • “Commissioning”: The Project will be considered as commissioned if all equipment as per rated Project Capacity has been installed and energy has flown into grid, in line with the Commissioning procedures as defined under the prevailing regulatory framework of the Appropriate Commission. • “Completion” means that the Facilities (or a specific part thereof where specific parts are specified in the Scope of Work) have been completed operationally and structurally and put in a tight and clean condition and that all work in respect of Commissioning of the Facilities or such specific part thereof has been completed as per the Scope of Work. • “Completion Certificate” shall mean the certificate to be issued by the owner or his representative when the works have been completed to his satisfaction. • “Contract” or “Contract Agreement” means the Contract signed between the Company (CIL/Subsidiary) and the Contractor to execute the entire Scope of Work as given in this RFP document. • “Contracted Capacity” shall mean 50 MW (AC) contracted with the Company for supply at the Delivery Point from the Project. • “Contracted CUF” shall mean the % capacity utilization factor of the project measured at the Delivery Point as specified in the Contract.
--	--	---

		<ul style="list-style-type: none"> • “Contractor” means the person(s) whose bid to perform the Contract has been accepted by the Company and is named as such the Contract Agreement, and includes the legal successors or permitted assigns of the Contractor. • “Contractor’s Equipment” means all plant, facilities, equipment, machinery, tools, apparatus, appliances or things of every kind required in or for installation, completion and maintenance of Facilities that are to be provided by the Contractor, but does not include Plant and Equipment, or other things intended to form or forming part of the Facilities. • “Day” means calendar day of the Gregorian/English calendar. • “Delivery Point” shall mean the supply points as specified in the NIT. Metering shall be done at this interconnection point where the power is injected into. For interconnection with grid and metering, the Contractor shall abide by the relevant and applicable regulations, Grid Code notified by the CERC or and Central Electricity Authority (Installation and Operation of Meters) Regulations, 2006 as amended and revised from time to time, or orders passed thereunder by the appropriate commission or CEA. • “Defect Liability Period” means the period of validity of the warranties given by the Contractor, during which the Contractor is responsible for defects with respect to the Facilities (or the relevant part thereof) as provided in Defect Liability clause hereof. Defect Liability Period shall be for a duration upto the end of the O&M period or as for any duration extended by the mutual agreement of both the parties. • “Effective Date” for this Contract shall mean the date of commencement of work • “Facilities” means the Plant and Equipment to be supplied and installed, as well as all the Installation Services to be carried out by the Contractor under the Contract for enabling the installation, construction, testing and commissioning of the Solar Power System(s). • “Government Authority” means Government of India, any state government or any governmental department, commission, board, body, bureau, agency, authority, undertaking, court or other judicial or administrative body or any sub-division or instrumentality thereof, central, state, or local, having jurisdiction over the Contractor, the Facility, or the performance of all or any of the services, obligations or covenants of Contractor under or pursuant to this Contract or any portion thereof. • “Guarantee Test(s)” means the Performance Guarantee test(s) specified in the Technical Specifications to be carried out to ascertain whether the Facilities or a specified part thereof is able to attain the Functional Guarantees. • “Installation Services” means all those services ancillary to the supply of the Plant and Equipment for the Facilities, to be provided by the Contractor under the Contract; e.g., transportation and provision of marine or other similar insurance, inspection, expediting, Site preparation works (including the provision and use of Contractor’s Equipment and the supply of all civil, structural and construction materials required),
--	--	---

			<p>installation, Commissioning, carrying out guarantee tests, operations, maintenance, the provision of operations and maintenance manuals, training of Company's personnel etc.</p> <ul style="list-style-type: none"> • “Interconnection Facilities” shall mean the facilities from the Project up to the grid connection point for scheduling, transmitting and metering the electrical output in accordance with the Long Term Open Access and which shall include, without limitation, all other transmission lines and associated equipment, transformers, relay and switching equipment and protective devices, safety equipment and RTU, Data Transfer and Acquisition facilities for transmitting data, the Metering System required for supply of power as per the terms of the Terms and conditions of the LTOA . • “Metering Point” shall have the same meaning as Delivery Point • “MNRE” means Ministry of New and Renewable Energy, Government of India. • “Month” means shall mean a period of thirty (30) days from (and excluding) the date of the event, where applicable, else a calendar month of the Gregorian/English calendar. • “O&M” means Operations and Maintenance. • “Project” or “Solar Power Project” or “Solar Project” is defined as the 20 MW(AC) Grid-Connected Solar Photovoltaic Power Plant proposed to be located in the State of Dhanbad and having a separate control system, metering and a single or multiple point(s) of injection into the grid at Delivery/Metering point at STU substation or in case of sharing of transmission lines, by separate injection at pooling point. This includes all units and auxiliaries such as water supply, treatment or storage facilities; bay/s for transmission system in the switchyard, dedicated transmission line up to the Delivery Point and all the other assets, buildings/structures, equipment, plant and machinery, facilities and related assets required for the efficient and economic operation of the power generation facility; whether completed or at any stage of development and construction or intended to be developed and constructed for the purpose of supply of power as per this Agreement;. • “Plant Capacity” or “Project Capacity” shall mean the Contracted Capacity of the Project measured at the Delivery Point. • "Prudent Utility Practices" shall mean those practices, methods, techniques and standards, that are generally accepted for use in electric utility industries taking into account conditions in India, and commonly used in prudent electric utility engineering and operations to design, engineer, construct, test, operate and maintain equipment lawfully, safely, efficiently and economically as applicable to power stations of the size, service and type of the Project, and that generally conform to the manufacturers' operation and maintenance guidelines. • “RFP document” or “Tender document” or “Tender” shall mean this bidding document issued by the Company including all attachments.
--	--	--	--

			<ul style="list-style-type: none"> • “Site” means the land and other places upon which the Facilities are to be installed, and such other land or places as may be specified in the Contract as forming part of the Site. • “Solar Power System(s)” means the solar photovoltaic grid interactive power system(s) to be established at the site specified in the RFP. • “Subcontractor”, including vendors, means any person to whom execution of any part of the Facilities, including preparation of any design or supply of any Plant and Equipment, is sub-contracted directly or indirectly by the Contractor, and includes its legal successors or permitted assigns. • “Successful Bidder” means the bidder who has been awarded the Contract and described as Contractor for the “Project”. • “Time for Completion” shall be the date on or before which Commissioning of the Facility has to be achieved to the satisfaction of the Company and such date is specified in NIT. • “Year” means a period of 12 full consecutive months or 365 consecutive days. • “Goods and Services Tax” or “GST” means taxes or cess levied under the Central Goods and Services Tax Act, Integrated Goods and Services Tax Act, Goods and Services Tax (Compensation to States) Act and various State/Union Territory Goods and Services Tax Laws and amendments thereof and applicable cesses, if any under the laws in force (hereinafter referred to as relevant GST Laws), which shall be fully complied with by Bidders.
--	--	--	---

SECTION - 7

SAFETY CODE

1. Suitable scaffolds should be provided for workmen for all works that cannot safely be done from the ground, or from solid construction except such short period work as can be done safely from ladders. When a ladder is used, an extra mazzdoor shall be engaged for holding the ladder and if the ladder is used for carrying materials as well suitable footholds and hand- hold shall be provided on the ladder and the ladder shall be given an inclination not steeper than $\frac{1}{4}$ to 1 ($\frac{1}{4}$ horizontal and 1 vertical).
2. Scaffolding of staging more than 3.6 m (12ft). above the ground or floor, swung or suspended from an overhead support or erected with stationary support shall have a guard rail properly attached or bolted, braced and otherwise secured at least 90 cm (3ft) high above the floor or platform of such scaffolding or staging and extending along the entire length of the outside and ends thereof with only such opening as may be necessary for the delivery of materials. Such scaffolding or staging shall be so fastened as to prevent it from swaying from the building or structure.
3. Working platforms, gangways and stairways should be so constructed that they should not sag unduly or unequally, and if the height of the platform or the gangway or the stairway is more than 3.6 m (12ft) above ground level, they should be closely boarded, should have adequate width and should be suitably fastened as described in (2) above.
4. Every opening in the floor of a building or in a working platform shall be provided with suitable means to prevent the fall of person or materials by providing suitable fencing or railing whose minimum height shall be 90 cm (3ft).
5. Safety means of access shall be provided to all working platforms and other working places. Every ladder shall be securely fixed. No portable single ladder shall be over 9 m (30ft) in length while the width between side rails in rung ladder shall in no case be less than 20 cm (11 $\frac{1}{2}$ "") for ladder up to and including 3 m (10ft) in length. For longer ladders, this width should be increased at least $\frac{1}{4}$ " for additional 30 cm (1ft.) of length. Uniform step spacing of not more than 30 cm shall be kept. Adequate precautions shall be taken to prevent danger from electrical equipment. No materials on any of the sites or work shall be so stacked or placed as to cause danger or inconvenience to any person or the public. The contractor shall provide all necessary fencing and lights to protect the public from accident and shall be bound to bear the expenses of defence of every suit, action or other proceedings at law that may be brought by any person for injury sustained owing to neglect of the above precautions and to pay any damages and cost which may be awarded in any such suit; action or proceedings to any such person or which may, with the consent of the contractor, be paid to compensate any claim by any such person.

- 6.** Excavation and Trenching: All trenches 1.2 m (4ft) or more in depth, shall at all times be supplied with at least one ladder for each 30 m. (100 ft.) in length or fraction thereof. Ladder shall extend from bottom of the trench to at least 90 cm (3ft) above the surface of the ground. The side of the trenches which are 1.5 m (5ft) or more in depth shall be stepped back to give suitable slope or securely held by timber bracing, so as to avoid the danger of sides collapsing. The excavated materials shall not be placed within 1.5 m (5ft) of the edges of the trench or half of the depth of the trench whichever is more. Cutting shall be done from top to bottom. Under no circumstances, undermining or undercutting shall be done.
- 7.** Demolition : before any demolition work is commenced and also during the progress of the work,
- i)** All roads and open areas adjacent to the work site shall either be closed or suitably protected.
 - ii)** No electric cable or apparatus which is liable to be a source of danger or a cable or apparatus used by the operator shall remain electrically charged.
 - iii)** All practical steps shall be taken to prevent danger to persons employed from risk of fire or explosion or flooding. No floor, roof or other part of the building shall be so overloaded with debris or materials as to render it unsafe.
- 8.** All necessary personal safety equipment as considered adequate by the Engineering-in-Charge should be kept available for the use of the person employed on the site and maintained in a condition suitable for immediate use, and the contractor should take adequate steps to ensure proper use of equipment by those concerned. The following safety equipment shall invariably be provided :
- i.** Workers employed on mixing asphaltic materials, cement and lime mortars shall be provided with protective footwear and protective goggles.
 - ii.** Those engaged in white washing and mixing or stacking of cement bags or any material which is injurious to the eyes, shall be provided with protective goggles.
 - iii.** Those engaged in welding works shall be provided with welder's protective eye shields.
 - iv.** Stone breaker shall be provided with protective goggles and protective clothing and seated at sufficiently safe intervals.
 - v.** When workers are employed in sewers and manholes, which are in active use, the contractors shall ensure that the manhole covers are opened and ventilated at least for an hour before the workers are allowed to get into the manholes, and the manholes so opened shall be cordoned off with suitable railing and provided with warning signals or boards to prevent accident to the public. In addition, the contractor shall ensure that the following safety measures are adhered to:-
 - a)** Entry for workers into the line shall not be allowed except under supervision of the Engineering Assistant or any other higher officer.
 - b)** At least 5 to 6 manholes upstream and downstream should be kept open for at least 2 to 3 hours before any man is allowed to enter into the manhole for working inside.

- c)** Before entry, presence of Toxic gases should be tested by inserting wet lead acetate paper which changes colour in the presence of such gases and gives indication of their presence.
- d)** Presence of Oxygen should be verified by lowering a detector lamp into the manhole. In case, no Oxygen is found inside the sewer line, workers should be sent only with Oxygen kit.
- e)** Safety belt with rope should be provided to the workers. While working inside the manholes, such rope should be handled by two men standing outside to enable him to be pulled out during emergency.
- f)** The area should be barricaded or cordoned off by suitable means to avoid mishaps of any kind. Proper warning signs should be displayed for the safety of the public whenever cleaning works are undertaken during night or day.
- g)** No smoking or open flames shall be allowed near the blocked manhole being cleaned.
- h)** The malba obtained on account of cleaning of blocked manholes and sewer lines should be immediately removed to avoid accidents on account of slippery nature of the malba.
- i)** Workers should not be allowed to work inside the manhole continuously. He should be given rest intermittently. The Engineer-in-Charge may decide the time up to which a worker may be allowed to work continuously inside the manhole.
- j)** Gas masks with Oxygen Cylinder should be kept at site for use in emergency.
- k)** Air-blowers should be used for flow of fresh air through the manholes. Whenever called for, portable air blowers are recommended for ventilating the manholes. The Motors for these shall be vapour proof and of totally enclosed type. Non sparking gas engines also could be used but they should be placed at least 2 meters away from the opening and on the leeward side protected from wind so that they will not be a source of friction on any inflammable gas that might be present.
- l)** The workers engaged for cleaning the manholes / sewers should be properly trained before allowing to work in the manhole.
- m)** The workers shall be provided with Gumboots or non-sparking shoes bump helmets and gloves non sparking tools safety lights and gas masks and portable air blowers (when necessary). They must be supplied with barrier cream for anointing the limbs before working inside the sewer lines.
- n)** Workmen descending a manhole shall try each ladder stop or rung carefully before putting his full weight on it to guard against insecure fastening due to corrosion of the rung fixed to manhole well.
- o)** If a man has received a physical injury, he should be brought out of the sewer immediately and adequate medical aid should be provided to him.

- p)** The extents to which these precautions are to be taken depend on individual situation but the decision of the Engineer-in-Charge regarding the steps to be taken in this regard in an individual case will be final.
- vi)** The Contractor shall not employ men and women below the age of 18 years on the work of painting with products containing lead in any form. Wherever men above the age of 18 are employed on the work of lead painting, the following precaution should be taken:-
- a)** No paint containing lead or lead products shall be used except in the form of paste or ready-made paint.
 - b)** Suitable face masks should be supplied for use by the workers when paint is applied in the form of spray or a surface having lead paint is dry rubbed and scrapped.
 - c)** Overalls shall be supplied by the contractors to the workmen and adequate facilities shall be provided to enable the working painters to wash during and on the cessation of work.
 - d)** Measures shall be taken, wherever practicable, to prevent danger arising out of dust caused by dry rubbing down and scraping.
 - e)** Adequate facilities shall be provided to enable working painters to wash during and on cessation of work.
 - f)** Overall shall be worn by working painters during the whole of working period.
 - g)** Suitable arrangement shall be made to prevent clothing put off during working hours being spoiled by painting materials.
- 9.** When the work is done near any place where there is risk of drowning, all necessary equipment should be provided and kept ready for use and all necessary steps taken for prompt rescue of any person in danger and adequate provision, should be made for prompt first aid treatment of all injuries likely to be obtained during the course of the work.
- 10.** Use of hoisting machines and tackle including their attachments, anchorage and supports shall conform to the following standards or conditions:-
- i.) (a)** These shall be of good mechanical construction, sound materials and adequate strength and free from patent defects and shall be kept repaired and in good working order.
 - (b)** Every rope used in hoisting or lowering materials or as a means of suspension shall be of durable quality and adequate strength, and free from patent defects.
 - ii)** Every crane driver or hoisting appliance operator, shall be properly qualified and no person under the age of 21 years should be in charge of any hoisting machine including any scaffolding winch or give signals to operator.
 - iii)** In case of every hoisting machine and of every chain ring hook, shackles, swivel and

pulley block used in hoisting or as means of suspension, the safe working load shall be ascertained by adequate means. Every hoisting machine and all gear referred to above shall be plainly marked with the safe working load. In case of a hoisting machine having a variable safe working load each safe working load and the condition under which it is applicable shall be clearly indicated. No part of any machine or any gear referred to above in this paragraph shall be loaded beyond the safe working load except for the purpose of testing.

iv) In case of departmental machines, the safe working load shall be notified by the Electrical Engineer-in-Charge. As regards contractor's machines the contractors shall notify the safe working load of the machine to the Engineer-in-Charge whenever he brings any machinery to site of work and get it verified by the Electrical Engineer concerned.

- 11.** Motors, gearing, transmission, electric wiring and other dangerous parts of hoisting appliances should be provided with efficient safeguards. Hoisting appliances should be provided with such means as will reduce to the minimum the risk of accidental descent of the load. Adequate precautions should be taken to reduce to the minimum the risk of any part of a suspended load becoming accidentally displaced. When workers are employed on electrical installations which are already energized, insulating mats, wearing apparel, such as gloves, sleeves and boots as may be necessary should be provided. The worker should not wear any rings, watches and carry keys or other materials which are good conductors of electricity.
- 12.** All scaffolds, ladders and other safety devices mentioned or described herein shall be maintained in safe condition and no scaffold, ladder or equipment shall be altered or removed while it is in use. Adequate washing facilities should be provided at or near places of work.
- 13.** These safety provisions should be brought to the notice of all concerned by display on a notice board at a prominent place at work spot. The person responsible for compliance of the safety code shall be named therein by the contractor.
- 14.** To ensure effective enforcement of the rules and regulations relating to safety precautions the arrangements made by the contractor shall be open to inspection by the Labour Officer or Engineer-in-Charge of the department or their representatives.
- 15.** Notwithstanding the above clauses from (1) to (15), there is nothing in these to exempt the contractor from the operations of any other Act or Rule in force in the Republic of India.

SECTION - 8

BID SUBMISSION CHECKLIST

[Note: Document Checklist shall be attached with Appendix 1 of the Technical Bid]

1	Letter of Bid (Appendix-1)	
2	Details of Site (Appendix-2)	
3	Form for Electronic Fund Transfer / Internet Banking Payment (Appendix-7)	
4	Power of Attorney (Appendix-8)	
5	Bid Securing Declaration (Appendix-12)	
6	Written Consent for Arbitration Clause (applicable for Partnership Firms and JVs) (Appendix-13)	
7	Undertaking (Appendix-14)	
8	Detailed Project Schedule (Appendix-15)	
9	Certificate of possessing adequate Working Capital – CA Certificate and Banker's Certificate, as applicable (as per Clause 8.A of e-Tender Notice)	
10	Attested copy of PAN Card of the Bidder (as per Clause 8.B of e-Tender Notice)	
11	Attested copy of GST Registration Certificate of the Bidder (as per Clause 8.C of e-Tender Notice)	
12	MoA and AoA along with Certificate of Incorporation of the Bidder as documentary support for legal status of the Bidder (as per Clause 9 of the e-Tender Notice)	
13	Declaration in compliance with the provisions of Public Procurement (Preference to Make in India), Order 2017-Revision vide order no. P-45021/2/2017/PP(BE-II) dtd 16.09.2020 of Ministry of Commerce and Industry, Government of India and amendments thereof (as per Clause 9 of the e-Tender Notice)	
14	Valid Digital Signature Certificate (Appendix-16)	
15	Filled-in BOQ Excel File	

APPENDIX-1: FORMAT FOR LETTER OF BID

(To be uploaded by the Bidder on his Letter Head during submission of bid online)To :

Sub : Project Name : _____

Tender No. & date : _____

Dear Sir,

This has reference to above referred bid. I/we have read and examined the conditions of contract, Scope of Work, technical specifications, BOQ and other documents carefully.

I /We am/are pleased to submit our bid for the above work. I/We hereby unconditionally accept the bid conditions and bid documents in its entirety for the above work and agree to abide by and fulfil all terms and conditions and specifications as contained in the bid document.

We hereby confirm total and unconditional acceptance of the TERMS and CONDITIONS OF CONTRACT (e-Tender Notice, General Terms and Conditions of Contract, Additional Terms and Conditions of Contract, General Technical Conditions of Contract, Erection Conditions of Contract, Special Conditions of Contract and Safety Code) and TECHNICAL SPECIFICATIONS as given in the Bid document.

We hereby also confirm that the detailed design and drawings will be submitted by us for approval, before execution of work and any changes/modifications suggested by you will be acceptable to us at the same Terms & Conditions of NIT and without any additional cost.

We hereby also confirm that any Item/Structure/Plant & Machinery, not specifically indicated in the Scope of work/Bill of Quantity, but subsequently felt necessary for satisfactory completion and commissioning of the Project, will be executed/supplied by us without any additional cost.

I/we here by submit all the documents as required to meet the eligibility criteria as per provision of the bid notice/document.

I/We hereby confirm that this bid complies with the Bid validity, Bid security and other documents as required by the Bidding documents.

If any information furnished by me/us towards eligibility criteria of this bid is found to be incorrect at any time, penal action as deemed fit may be taken against me/us for which I/We shall have no claim against CIL/Subsidiary.

Until a formal agreement is prepared and executed, this bid and your subsequent Letter of Acceptance/Work Order shall constitute a binding contract between us and Bharat Coking Coal Limited

Should this bid be accepted, we agree to furnish Performance Security within **stipulated date** and commence the work within **stipulated date**. In case of our failure to abide by the said provision, Coal India Limited shall, without prejudice to any other right or remedy, be at liberty to cancel the letter of acceptance/ Work Order/Award and also ban us **for 02 (two) years from being eligible to submit Bids in CIL and its subsidiaries**.

Date :

Yours faithfully, Signature of
Bidder with Seal

APPENDIX-2: DETAILS OF SITE

(to be furnished by the Bidder in the Bid at the time of signing agreement)

Location	Area of land (Acres)	Solar Irradiation (GHI and DNI) at the place where the Land is located	Interconnection Point(s) with Sub- station names, voltage and spare capacities	Distance of Project site / Land from the Interconnection Point (in km)

Signature of Bidder with Seal

**PAGE LEFT
BLANK**

APPENDIX-3: FORMAT FOR BANK GUARANTEE

To
GM (E&M),
Bharat Coking Coal Limited,
Koyla Bhawan, Koyla Nagar, BCCL Township,
Dhanbad, Jharkhand – 826005.

Dear Sir,

In consideration of..... having its Registered Office at (hereinafter called “the Company” which expression shall unless repugnant to the subject or context includes its successors and assigns) having agreed under the terms and conditions contained in letter No..... dated..... issued in favour of M/s..... for (hereinafter referred to as “the contract” to accept the Deed of guarantee as herein provided for Rs..... from the Schedule/ Nationalised Bank in lieu of security deposit to be made by M/s..... (hereinafter called “the Contractor”) or in lieu of deduction to be made from the contractor’s bill, for the due fulfillment of the terms and conditions contained in the said contract by the contractor, we the Bank (hereinafter referred to as the said Bank) having its Registered Office at..... do hereby undertake and agreed to pay the company to the extent of Rs..... on demand stating that the amount claimed by the company is due and payable by the contractor for the reasons of failure/negligence in performing the terms and conditions contained in the contract by the buyer and to unconditionally pay the amount claimed by the company on demand without any demur to the extent aforesaid.

We..... Bank agree that the company shall be the sole judge as to whether the said contractor has failed/neglected in performing any of the terms and conditions of the said contract and the decision of the company in this behalf shall be final and binding on us.

We the said Bank further agree that the Guarantee herein contained shall remain in full force and effect upto and any claim received after the said date shall in no case bind the Bank.

The Company shall have the fullest liberty without affecting in any way the liability of the Bank under this guarantee or indemnity from time to time vary any of the terms and conditions of the said contract or to extend the time of performance by the said contractor or to postpone any time and from time to time any of the powers exercisable by it against the said contractor and either to enforce or to forbear from enforcing any of the terms and conditions governing the said contract or securities available to the company and the said Bank shall not be released from its liability under these presents.

Notwithstanding anything contained herein the liability of the said Bank under this guarantee is restricted to Rs..... and this Guarantee shall come into force from the date hereof and shall remain in full force and effect till

Unless the written demand or claim under this guarantee is made by the Company with us on or before all rights of the company under this guarantee shall cease to have any effect and we shall be relieved and discharged from our liabilities hereunder.

We the said Bank lastly undertake not to revoke this guarantee during its currency except with the previous consent of the company in writing and agree that any change in the constitution of the said

contractor or the said bank shall not discharge our liability hereunder.

This guarantee issued by Sri who is authorized by the Bank.

Under jurisdiction of High Court of Jharkhand only.

- a) The Bank Guarantee shall also be operative at our Branch Located at (Detailed address), from whom, confirmation regarding issue of this guarantee or extension/ renewal thereof shall be made available on demand.
- b) Any notice by way of request, demand or otherwise hereunder may be sent by post/ e-mail/ Fax addressed to the bank branch/ operative branch, which shall be deemed to be a sufficient demand notice. Bank shall effect payment thereof forthwith.
- c) The Complete Postal address with PIN Code, Branch Code, IFSC Code, SWIFT, Telephone No., FAX No. and E-mail ID of both outstation bank issuing the BG and Local operating Branch of the Bank issued the BG are as under:-

Sl No.	Particulars	Outstation Bank Issuing the Bank Guarantee	Local Operating Branch of the Bank Issued the Bank Guarantee
1	Complete Postal Address with PIN Code		
2	Branch Code		
3	IFSC Code		
4	SWIFT		
5	Telephone No.		
6	Fax No.		
7	e-mail ID		

- d) Whenever there is change in postal address and/ or other details of this branch issued the guarantee and/or the operative branch, we (the issuing bank) will ensure to intimate BCCL, being the beneficiary, of such changed address, telephone number, fax number and e-mail ID.

Signature of the authorized person
For and on behalf of the Bank

Place

Note – (i) Bank Guarantees issued by outstation Banks shall be operative at their local branch.

(ii) The bank guarantees issued by the issuing bank on behalf of contractor, supplier, customer in favour of Bharat Coking Coal Ltd. shall be in paper form as well as Structured Financial Messaging System (SFMS).

(iii) BCCL has chosen ICICI Bank to act advising/ beneficiary bank of company. The bank issuing the guarantee can choose either of these bank to send confirmation through SFMS.

(iv) The details of beneficiary (i.e. BCCL) for issue of bank guarantee in SFMS platform is as furnished as below.

State Bank of India as advising bank of BCCL

1.	Name and details of the Beneficiary	i.	Name	Bharat Coking Coal Limited
		ii.	Area	Head Quarter
		iii.	Name of Bank	State Bank of India
		iv.	Bank Account No.	35160317947
		v.	Department	E&M Department
2.	Beneficiary's advising Bank, Branch and Address for confirmation of BGs through SFMS	i.	Name of Bank	State Bank of India
		ii.	Bank Branch Name	Dhanbad
		iii.	Branch Code	000066
		iv.	Beneficiary Bank Branch IFSC	SBIN0000066
		v.	Beneficiary Bank Address	Bank More, Dhanbad, Jharkhand

(v)The Supplier/ Contractor/ Customers are required to take note of it that above particulars are to be incorporated by the issuing bank properly while issuing the BankGuarantee under SFMS mode to avoid any future problem in accepting the BGs.

(vi) The Guarantor (BG issuing bank) shall send information about issuance of this Guarantee through SFMS gateway to the State Bank of India, Dhanbad Branch, Dhanbad, as the case may be, to aid in the process of confirmation of Bank Guarantee.

(vii)The Guarantor (BG issuing bank) shall also send information about issuance of thisGuarantee to its local operating branch at Dhanbad, Dhanbad to aid in process ofconfirmation as well as claim for encashment of Bank Guarantee.

(viii) The Original Bank Guarantee issued by the outstation bank shall be sent by the Issuing Bank to the Concerned Department of Head Quarters of BCCL at the Office of GM (E&M), Bharat Coking Coal Limited, Koyla Bhawan, Koyla Nagar, BCCL Township,Dhanbad, Jharkhand – 826005 by Speed Post/ Registered Post (AD).

APPENDIX-4: PRE-CONTRACT INTEGRITY PACT

General

This pre-bid pre-contract Agreement (hereinafter called the Integrity Pact) is made on.....day of the month of20..., between, on one hand, Coal India Limited/Subsidiary Cos. acting through Shri, Designation of the officer, (hereinafter called the “BUYER / Principal”, which expression shall mean and include, unless the context otherwise requires, his successors in office and assigns) of the First Part and M/s.

.....represented by Shri... .., Chief Executive Officer (hereinafter called the “BIDDER/Seller/Contractor” which expression shall mean and include, unless the context otherwise requires, his successors and permitted assigns) of the Second Part.

WHEREAS the BUYER proposes to procure(Name of the Stores/Equipment/Item) and the BIDDER/Seller is willing to offer/has offered the stores and

WHEREAS the BIDDER is a private company/public company/Government undertaking/partnership/registered export agency, constituted in accordance with the relevant law in the matter and the BUYER is a Central Public Sector Unit.

NOW, THEREFORE,

To avoid all forms of corruption by following a system that is fair, transparent and free from any influence/prejudiced dealings prior to, during and subsequent to the currency of the contract to be entered into with a view to :-

Enabling the BUYER to obtain the desired said stores/equipment at a competitive price in conformity with the defined specifications by avoiding the high cost and the distortionary impact of corruption on public procurement, and

Enabling BIDDERS to abstain from bribing or indulging in any corrupt practice in order to secure the contract by providing assurance to them that their competitors will also abstain from bribing and other corrupt practices and the BUYER will commit to prevent corruption, in any form, by its officials by following transparent procedures.

The parties hereto hereby agree to enter into this Integrity Pact and agree as follows:

Section 1 – Commitments of the Principal

(1) The Principal commits itself to take all measures necessary to prevent corruption and to observe the following principles:-

a. No employee of the Principal, personally or through family members, will in connection with the tender for, or the execution of a contract, demand; take a promise for or accept, for self or third person, any material or immaterial benefit which the person is not legally entitled to.

b. The Principal will, during the tender process treat all Bidder(s) with equity and reason. The Principal will in particular, before and during the tender process, provide to all Bidder(s) the same information and will not provide to any Bidder(s) confidential / additional information through which the Bidder(s) could obtain an advantage in relation to the tender process or the contract execution.

c. Principal will exclude from the process all known prejudiced persons.

(2) If the Principal obtains information on the conduct of any of its employees which is a criminal offence under the IPC/ PC Act, or if there be a substantive suspicion in this regard, the Principal will inform the Chief Vigilance Officer and in addition can initiate disciplinary actions.

Section 2 - Commitments of the Bidder(s)/ Contractor(s)

(1) The Bidder(s) / Contractor(s) commit themselves to take all measures necessary to prevent corruption. The Bidder(s) / Contractor(s) commit themselves to observe the following principles during participation in the tender process and during the contract execution.

a. The Bidder(s) / Contractor(s) will not, directly or through any other person or firm, offer, promise or give to any of the Principal's employees involved in the tender process or the execution of the contract or to any third person any material or other benefit which he/ she is not legally entitled to, in order to obtain in exchange any advantage of any kind whatsoever during the tender process or during the execution of the contract.

b. The Bidder(s) / Contractor(s) will not enter with other Bidders into any undisclosed agreement or understanding, whether formal or informal. This applies in particular to prices,

specifications, certifications, subsidiary contracts, submission or non- submission of bids or any other actions to restrict competitiveness or to introduce cartelization in the bidding process.

c. The Bidder(s) / Contractor(s) will not commit any offence under the relevant IPC/ PC Act; further the Bidder(s) / Contractor(s) will not use improperly, for purposes of competition or personal gain, or pass on to others, any information or document provided by the Principal as part of the business relationship, regarding plans, technical proposals and business details, including information contained or transmitted electronically.

d. The Bidder(s) / Contractor(s) of foreign origin shall disclose the name and address of the Agents/ representatives in India, if any, similarly the Bidder(s) /Contractor(s) of Indian Nationality shall furnish the name and address of the foreign principals, if any. Further details as mentioned in the "Guidelines on Indian Agents of Foreign Suppliers" shall be disclosed by the Bidder(s) / Contractor(s). Further, as mentioned in the Guidelines all the payments made to the Indian agent/ representative have to be in Indian Rupees only. The guidelines and terms and conditions for Indian agents of foreign supplier shall be as per the provisions at Annexure-1 of this document.

e. The Bidder(s) / Contractor(s) will, when presenting their bid, disclose any and all payments made, is committed to or intends to make to agents, brokers or any other intermediaries in connection with the award of the contract.

f. Bidder(s) / Contractor(s) who have signed the Integrity Pact shall not approach the Courts while representing the matter to IEMs and shall wait for their decision in the matter.

(2) The Bidder(s) / Contractor(s) will not instigate third persons to commit offences outlined above or be an accessory to such offences.

Section 3 - Disqualification from tender process and exclusion from future contracts

If the Bidder, before contract award, has committed a transgression through a violation of Section 2 or in any other form such as to put his reliability or credibility as Bidder into question, the Principal is entitled to disqualify the Bidder from the tender process or to terminate the contract, if already signed, for such reason.

(1) If the Bidder / Contractor / Supplier has committed a transgression through a violation of Section 2 such as to put his reliability or credibility into question, the Principal is also entitled to exclude the

Bidder / Contractor / Supplier from future contract award processes. The imposition and duration of the exclusion will be determined by the severity of the transgression. The severity will be determined by the circumstances of the case. In particular the number of transgressions, the position of the transgressors within the company hierarchy of the Bidder and the amount of the damage. The exclusion will be imposed for a minimum of 6 months and maximum of 3 years.

(2) A transgression is considered to have occurred if the Principal, after due consideration of available facts and evidences within his / her knowledge concludes that there is a reasonable ground to suspect violation of any commitment listed under Section 2 i.e “ Commitments of Bidder(s) / Contractor(s).

(3) The Bidder accepts and undertakes to respect and uphold the Principal’s absolute right to resort to and impose such exclusion and further accepts and undertakes not to challenge or question such exclusion on any ground, including the lack of any hearing before the decision to resort to such exclusion is taken. This undertaking is given freely and after obtaining independent legal advice.

(4) If the Bidder / Contractor / Supplier can prove that he has restored / recouped the damage caused by him and has installed a suitable corruption prevention system, the Principal may revoke the exclusion prematurely.”

Section 4 - Compensation for Damages

(1) If the Principal has disqualified the Bidder(s) from the tender process prior to the award according to Section 3, the Principal is entitled to demand and recover the damages equivalent to Earnest Money Deposit/ Bid Security.

(2) If the Principal has terminated the contract according to Section 3, or if the Principal is entitled to terminate the contract according to Section 3, the Principal shall be entitled to demand and recover from the Contractor liquidated damages of the Contract value or the amount equivalent to Performance Bank Guarantee.

Section 5 - Previous transgression

(1) The Bidder declares that no previous transgressions occurred in the last three years with any other Company in any country conforming to the anti-corruption approach or with any Public Sector Enterprise in India that could justify his exclusion from the tender process.

(2) If the Bidder makes incorrect statement on this subject, he can be disqualified from the tender process or action can be taken as per the procedure mentioned in "Guidelines on Banning of business dealings".

Section 6 - Equal treatment of all Bidders / Contractors / Subcontractors

(1) In case of Sub-contracting, the Principal Contractor shall take the responsibility of the adoption of Integrity Pact by the Sub-contractor.

(2) The Principal will enter into agreements with identical conditions as this one with all Bidders and Contractors.

(3) The Principal will disqualify from the tender process all bidders who do not sign this Pact or violate its provisions.

Section 7 - Criminal charges against violating Bidder(s) / Contractor(s) / Subcontractor(s)

If the Principal obtains knowledge of conduct of a Bidder, Contractor or Subcontractor, or of an employee or a representative or an associate of a Bidder, Contractor or Subcontractor which constitutes corruption, or if the Principal has substantive suspicion in this regard, the Principal will inform the same to the Chief Vigilance Officer.

Section 8 - Independent External Monitor

(1) The Principal appoints competent and credible Independent External Monitor for this Pact after approval by Central Vigilance Commission. The task of the Monitor is to review independently and objectively, whether and to what extent the parties comply with the obligations under this agreement.

(2) The Monitor is not subject to instructions by the representatives of the parties and performs his/her functions neutrally and independently. The Monitor would have access to all Contract documents, whenever required. It will be obligatory for him / her to treat the information and documents of the Bidders/Contractors as confidential.

He/ she reports to the Chairman, Coal India Limited.

(3) The Bidder(s) / Contractor(s) accepts that the Monitor has the right to access without restriction to all Project documentation of the Principal including that provided by the Contractor. The Contractor will also grant the Monitor, upon his/ her request and demonstration of a valid interest, unrestricted and unconditional access to their project documentation. The same is applicable to Sub-contractors.

(4) The Monitor is under contractual obligation to treat the information and documents of the Bidder(s) / Contractor(s) / Sub-contractor(s) with confidentiality. The Monitor has also signed declarations on 'Non-Disclosure of Confidential Information' and of 'Absence of Conflict of Interest'. In case of any conflict of interest arising at a later date, the IEM shall inform Chairman, Coal India Limited and recuse himself / herself from that case.

(5) The Principal will provide to the Monitor sufficient information about all meetings among the parties related to the Project provided such meetings could have an impact on the contractual relations between the Principal and the Contractor. The parties offer to the Monitor the option to participate in such meetings.

(6) As soon as the Monitor notices, or believes to notice, a violation of this agreement, he/she will so inform the Management of the Principal and request the Management to discontinue or take corrective action, or to take other relevant action. The monitor can in this regard submit non-binding recommendations. Beyond this, the Monitor has no right to demand from the parties that they act in a specific manner, refrain from action or tolerate action.

(7) The Monitor will submit a written report to the Chairman, Coal India Limited within 8 to 10 weeks from the date of reference or intimation to him by the Principal and, should the occasion arise, submit Bids for correcting problematic situations.

(8) If the Monitor has reported to the Chairman, Coal India Limited, a substantiated suspicion of an offence under relevant IPC/ PC Act, and the Chairman, Coal India Limited has not, within the reasonable time taken visible action to proceed against such offence or reported it to the Chief Vigilance Officer, the Monitor may also transmit this information directly to the Central Vigilance Commissioner.

(9) The word 'Monitor' would include both singular and plural.

Section 9 - Pact Duration

This Pact begins when both parties have legally signed it. It expires for the Contractor 12 months after the last payment under the contract, and for all other Bidders 6 months after the contract has been awarded. Any violation of the same would entail disqualification of the bidders and exclusion from future business dealings.

If any claim is made / lodged during this time, the same shall be binding and continue to be valid despite the lapse of this pact as specified above, unless it is discharged / determined by Chairman , Coal India Limited.

Section 10 - Other provisions

(1) Changes and supplements as well as termination notices need to be made in writing. Side agreements have not been made.

(2) If the Contractor is a partnership or a consortium, this agreement must be signed by all partners or consortium members.

(3) Should one or several provisions of this agreement turn out to be invalid, the remainder of this agreement remains valid. In this case, the parties will strive to come to an agreement to their original

intentions.

(4) Issues like Warranty / Guarantee etc. shall be outside the purview of IEMs.

(5) In the event of any contradiction between the Integrity Pact and its Annexure, the Clause in the Integrity Pact will prevail.

Section 11- Facilitation of Investigation

In case of any allegation of violation of any provisions of this Pact or payment of commission, the BUYER or its agencies shall be entitled to examine all the documents including the Booksof Accounts of the BIDDER and the BIDDER shall provide necessary information and documents in English and shall extend all possible help for the purpose of such examination.

Section 12- Law and Place of Jurisdiction

This Pact is subject to Indian Law. The place of performance and jurisdiction of High Court of Jharkhand.

Section 13 - Other Legal Actions.

The actions stipulated in this Integrity Pact are without prejudice to any other legal action that may follow in accordance with the provisions of the extant law in force relating to any civil or criminal proceedings.

(For & On behalf of the Principal) (For & On behalf of Bidder/ Contractor)

(Office Seal)

(Office Seal)

Place.....

Date

Witness 1:

(Name & Address)

Witness 2:

(Name & Address)

APPENDIX-5: ILLUSTRATIVE COMPUTATION OF EVALUATED BIDVALUE (EBV)

The Evaluated Bid Value (EBV) shall be calculated using the following parameters: Parameters Quoted by the Bidder:

- i. Quoted Supply Price (in INR),
- ii. Quoted Works Price (in INR),
- iii. Quoted O&M Price for each year during the O&M period (of 5 years) (in INR),
- iv. Quoted Annual Net Electrical Energy Generation Guarantee (NEEGG) at the metering point of the Plant for each year during the O&M period (of 5 years) (in kWh).

Parameters assumed constant for evaluation of each Bidder:

- i. Discount Factor of 7.55 % annually.

The Evaluated Bid Value (EBV) shall be calculated using the abovementioned parameters as follows:

Step 1		Quoted total Supply Price (in INR)
Step 2		Quoted total Works Price (in INR)
Step 3		Net Present Value (NPV) of 5 years of O&M Cost quoted by the Bidder (in INR)
Step 4	ADD	Summation of Supply Price and Works Price (sum of Step 1 and 2) and NPV of O&M Price for 5 years (INR)
Step 5		Summation of quoted NEEGG for 5 years (kWh)
Step 6	DIVIDE	(Sum of Supply Price, Works Price and NPV of each year O&M Contract Price for 5 years) divided by (Summation of quoted NEEGG for 5 years) i.e. <i>(Step 4 / Step 5)</i>

The Evaluated Bid Value (EBV) shall be the Net Present Value (NPV) as calculated above.

Evaluated Bid Value (EBV) =

$$[(\text{Quoted Supply Price}) + (\text{Quoted Works Price}) + (\text{Total NPV of each year O\&M Contract Price of 5 years})]$$

Σ NEEGG of 5 years

The Bidder with the lowest EBV in INR / kWh shall be the Successful Bidder.

EXAMPLE:

The following example will further clarify the methodology of comparison:

Figures Quoted by Bidder 1:

Supply Cost (INR)	Works Cost (INR)	Year	NPV of O&M Cost (Total)		NEEGG (kWh)		EBV (INR/kWh)
			Yearly Cost (INR)	Total Cost (INR)	Yearly Generation (KWh)	Total Generation (kWh)	
(A)	(B)			(C)		(D)	F=(A+B+C)/D
3,83,50,00,00	1,20,00,00,00	1	2,18,00,000	9,65,67,460	40,00,00,00	2,00,00,00,00	2.56
		2	2,04,78,920		40,00,00,00		
		3	1,92,38,500		40,00,00,00		
		4	1,80,72,200		40,00,00,00		
		5	1,69,77,840		40,00,00,00		

EBV of Bidder 1 is INR 2.56/kWh.

Figures Quoted by Bidder 2:

Supply Cost (INR)	Works Cost (INR)	Year	NPV of O&M Cost (Total)		NEEGG (kWh)		EBV (INR/kWh)
			Yearly Cost (INR)	Total Cost (INR)	Yearly Generation (KWh)	Total Generation (kWh)	
(A)	(B)			(C)		(D)	F=(A+B+C)/D
3,96,82,22,00	1,42,00,00,00	1	2,28,90,000	10,13,95,833	45,00,00,00	2,25,00,00,00	2.44
		2	2,15,02,866		45,00,00,00		
		3	2,02,00,425		45,00,00,00		
		4	1,89,75,810		45,00,00,00		
		5	1,78,26,732		45,00,00,00		

EBV of Bidder 2 is INR 2.44/kWh.

EBV of Bidder 1 is higher than Bidder 2.

Bidder with lower EBV in INR / kWh shall be L-1. Hence, in the above illustrative computation, Bidder 2 would be preferred as the Successful Bidder (L-1) compared to Bidder 1.

Signed and seal

APPENDIX-6: FORMAT FOR PRE-BID QUERIES

Sl. No.	Chapter No.	Clause No.	Page No.	Tender Term	Bidder's Query

Sign with seal

**APPENDIX-7: MANDATE FORM FOR ELECTRONIC FUNDTRANSFER /
INTERNET BANKING PAYMENT**

1. Name of the Bidder :.....

2. Address of the Bidder :

.....

City.....

Pin Code.....

E-mail Id

Permanent Account Number

3. Particulars of Bank:

Bank Name		Branch Name	
Branch Place		Branch City	
PIN Code		Branch Code	
MICR No.			
Digital Code number appearing on the MICR Band of the cheque supplied by the Bank. Plea se attach Xerox copy of a cheque of your Bank for ensuring accuracyof the Bank Name, Branch Name and Code Number.			
RTGS Code			
Account Type	Savings	Current	Cash Credit
Account Number (as appearing in theCheque Book.)			

4. Date from which the mandate should be effective :

I hereby declare that the particulars given above are correct and complete. If any transaction is delayed or not effected for reasons of incomplete or incorrect information.I shall not hold Company responsible. I also undertake to advise any change in the particulars of my account to facilitate updation of records for purpose of credit of amountthrough SBI Net / RTGS transfer/NEFT. I agree to discharge responsibility expected of me as a participant under the scheme.

Any bank charges levied by the bank for such e-transfer shall be borne by us.Place:

Date:
Signature of the Party / Authorised Signatory

Certified that particulars furnished above are correct as per our records. Banker's Stamp:

Date:

(Signature of the Authorized official from the Bank)

APPENDIX-8: FORMAT FOR POWER OF ATTORNEY

(TO BE SUBMITTED ON NON-JUDICIAL STAMP PAPER OF MINIMUM VALUE OF RS.100/- DULY NOTARIZED)

Know all men by these presents, We, *[name of entity / Lead member of consortium and address of the registered office]* do hereby constitute, nominate, appoint and authorize Mr. / Ms. *[name]*, son/ daughter/ wife of *[name]*, and presently residing at *[address]*, who is presently employed with/ retained by us and holding the position of *[designation]* as our true and lawful attorney (hereinafter referred to as the “Authorized Representative”), to do in our name and on our behalf, all such acts, deeds and things as are necessary or required in connection with or incidental to submission of our bid for Design, Engineering, Supply and Procurement, Construction, Erection, Testing, Commissioning, and Operation and Maintenance of Solar Photovoltaic Grid-Connected Power Plant of capacity 20 MW (AC) including Evacuation Infrastructure in the State of Dhanbad (W.B) for Bharat Coking Coal Ltd. (the “Client”), including but not limited to signing and submission of all applications, proposals and other documents and writings, participating in pre-bid and other conferences and providing information/responses to the Client, representing us in all matters before the Client, signing and execution of all contracts and undertakings consequent to acceptance of our proposal and generally dealing with the Client in all matters in connection with or relating to or arising out of our Application.

AND, we do hereby agree to ratify and confirm all acts, deeds and things lawfully done or caused to be done by our said Authorized Representative pursuant to and in exercise of the powers conferred by this Power of Attorney and that all acts, deeds and things done by our said Authorized Representative in exercise of the powers hereby conferred shall and shall always be deemed to have been done by us.

IN WITNESS WHEREOF WE, *[name of entity / Lead member of consortium]*, THE ABOVE NAMED PRINCIPAL HAVE EXECUTED THIS POWER OF ATTORNEY ON THIS *[date in words]* DAY OF *[month]* *[year in “yyyy” format]*.

For *[name and registered address of entity / Lead member of consortium]*
[Signature]
[Name]
[Designation]

Witnesses:

1. *[Signature, name and address of witness]*
2. *[Signature, name and address of witness]*

Accepted
[Signature]
[Name]
[Designation]

[Address]

Notes:

- 1.** The mode of execution of the Power of Attorney should be in accordance with the procedure, if any, laid down by the applicable law and the charter documents of the executants(s) and when it is so required the same should be under seal affixed in accordance with the required procedure.
- 2.** Wherever required, the Applicant should submit for verification the extract of the charter documents and other documents such as a resolution / power of attorney in favour of the person executing this Power of Attorney for the delegation of power hereunder on behalf of the Applicant

APPENDIX-9: PROFORMA FOR EXECUTION OF AGREEMENT

NON-JUDICIAL STAMP PAPER (of appropriate value as per Stamp Act)

This agreement is made on day of between (Name of Company) having its registered office at (here-in-after called the ‘COMPANY’ which expression shall, unless repugnant to the subject or context, include its successors and assignees) of the one part and (Name of the Contractor) carrying on business as a (partnership / proprietorship / Ltd. Co. etc.) firm under the name and style (here-in-after called the ‘said Contractor’ which expression shall, unless the context requires otherwise include them and their respective heirs, executors, administrators and legal representatives) of the other part.

Whereas the Company invited tenders for the work of “... ..” and whereas the said Contractor/ Firm submitted tender for the said work and whereas the tender of the said contract has been accepted by the Company for execution of the said work.

NOW THIS AGREEMENT WITNESSETH AS FOLLOWS:

1. In this agreement words and expressions shall have the same meaning as are respectively assigned to them in the tender papers hereinafter referred to.
2. The following documents which are annexed to this agreement should be deemed to form and be read and construed as part of this agreement viz.
 - i) Annexure-A Tender Notice (Page .. to ..)
 - ii) Schedule-A General Terms & Conditions, Special Conditions, General Technical Conditions, Erection Conditions of Contract, Technical Specifications and Safety Code (Page to)
 - iii) Schedule-B The probable Quantities and Amount (Page to ..)
 - iv) Schedule-C Negotiation letters (Page to ..)
 - v) Schedule-D Letter of Acceptance/Work Order (Page to ..)
 - v) Schedule-E Drawings (Page to ..)
3. In consideration for the payment of the sum of Rs... ..(W/O Value; both in words and figures) or such other sum as may be arrived at under the clause of the specification relating to Payment by items measurements at unit prices by the Company, the said Contractor shall, subject to the terms & condition contained herein execute and complete the work as described and to the extent of probable

Quantities as indicated in Schedule B with such variations by way of alteration, addition to or reduction from the said works.

4. The company has received a sum of Rs..... towards Performance Security Deposit (1st part of Security Deposit) in the form of B.G.
5. The said contractor hereby covenants with the company that the company shall deduct at 5% of R/A Bills as Retention Money (2nd part of security deposit) to make the total Security as 10% (ten percent) of contract value, as per the terms & condition of the tender/ contract.

IN WITNESS WHEREOF THE parties herein have set their hands and seals the date and year above written.

1 Partner. Signature

2 Partner Signature

On behalf of M/S.....
The Contractor, as one of the constituted attorney, In the presence of –

1. Name _____ Signature

Address:

Occupation:

Signed by Srion behalf of Signature
(Name of Company) in presence of -

1. Name: Signature

2. Address:.

**APPENDIX-10: PROFORMA OF MEMORANDUM (To be a Part of
Contract Agreement)**

TENDER FOR WORK

I/We hereby tender for the execution for the BCCL of the work specified in the underwritten MEMORANDUM at rates specified in the Price-bid within a period of -----
Days as per LOA / Work Order and subject to the annexed conditions of Contract and with such materials as are provided for by and in all other respects in accordance with such conditions so far as applicable.

MEMORANDUM

1	Name of Work	
2	Agreement Value of Work	
3	Performance Security Deposit	
4	Additional Performance Security Deposit	
5	Percentage to be deducted from Bills	
6	Scheduled Date of Commencement of Work	
7	Scheduled Date of Completion of Work	

APPENDIX-11: TECHNICAL SPECIFICATIONS

Enclosed separately

APPENDIX-12: BID SECURING DECLARATION

(On Letter Head of Bidder)

I / We,....., Proprietor/Partner/Legal
Attorney/Director/Accredited Representative of M/S and submitting
Bid for the
work.....
.....against NIT
No.....Dated.....solemnly declares that:

- i)** If, I/We withdraw or modify my/our Bids during the period of validity,OR
- ii)** If, I/We am/are awarded the contract and fail to sign the contract within the stipulated time as per bid document,

OR
- iii)** If, I/We, fail to submit Performance Security before deadline,OR
- iv)** Any other default which attracts forfeiture of EMD as defined in the Tender documents, then,I/We will be banned for 02 (two) years from being eligible to submit Bids in CIL and its subsidiaries.

Signature of the Bidderor
his Authorized representatively
(In case of partnership / JV, signature of all partnersof
partnership firm / JV)

Date.....

APPENDIX-13: PROFORMA FOR WRITTEN CONSENT FOR ARBITRATION CLAUSE

(Applicable for Partnership Firm & Joint Venture)

We, all the Partners of M/s (Partnership Firm / Joint Venture), do hereby give our written consent for acceptance of the following Arbitration Clause of the NIT for the Work “.....” tendered by BCCL vide NIT No..... dated and Tender Id

A. Settlement of Disputes.

It is incumbent upon the contractor to avoid litigation and disputes during the course of execution. However, if such disputes take place between the contractor and the department, effort shall be made first to settle the disputes at the company level.

The contractor should make request in writing to the Engineer-in-charge for settlement of such disputes/ claims within 30 (thirty) days of arising of the cause of dispute/ claim failing which no disputes/ claims of the contractor shall be entertained by the company.

Effort shall be made to resolve the dispute in two stages

In first stage dispute shall be referred to Area GM or Engineer in Charge. If difference still persist the dispute shall be referred to a committee constituted by the owner. The committee shall have one member of the rank of Director of the company who shall be chairman of the committee.

If differences still persist, the settlement of the dispute shall be resolved in the following manner:

Disputes relating to the commercial contracts with Central Public Sector Enterprises / Govt. Departments (except Railways, Income Tax, Customs & Excise)/ State Public Sector Enterprises shall be referred by either party for Arbitration to the PMA (Permanent Machinery of Arbitration) in the department of Public Enterprises.

In case of parties other than Govt. Agencies, the redressal of the dispute may be sought through Arbitration (THE ARBITRATION AND CONCILIATION ACT, 1996 as amended by AMENDMENT ACT of 2015).

B. Settlement of Disputes through Arbitration

If the parties fail to resolve the disputes/differences by in house mechanism, then, depending on the position of the case, either the employer/owner or the contractor shall give notice to other party to refer the matter to arbitration instead of directly approaching

Court. The contractor shall, however, be entitled to invoke arbitration clause only after exhausting the remedy available under the clause 16.

In case of parties other than Govt. agencies, the redressal of disputes/differences shall be sought through Sole Arbitration as under.

Sole Arbitration:

In the event of any question, dispute or difference arising under these terms & conditions or any condition contained in this contract or interpretation of the terms of, or in connection with this Contract (except as to any matter the decision of which is specially provided for by these conditions), the same shall be referred to the sole arbitration of a person, appointed to be the arbitrator by the Competent Authority of CIL / CMD of Subsidiary Company (as the case may be). The award of the arbitrator shall be final and binding on the parties of this Contract.

(a) In the event of the Arbitrator dying, neglecting or refusing to act or resigning or being unable to act for any reason, or his/her award being set aside by the court for any reason, it shall be lawful for the Competent Authority of CIL / CMD of Subsidiary Company (as the case may be) to appoint another arbitrator in place of the outgoing arbitrator in the manner aforesaid.

(b) It is further a term of this contract that no person other than the person appointed by the Competent Authority of CIL / CMD of Subsidiary Company (as the case may be) as aforesaid should act as arbitrator and that, if for any reason that is not possible, the matter is not to be referred to Arbitration at all.

Subject as aforesaid, Arbitration and Conciliation Act, 1996 as amended by Amendment Act of 2015, and the rules thereunder and any statutory modification thereof for the time being in force shall be deemed to apply to the Arbitration proceedings under this clause.

The venue of arbitration shall be the place from which the contract is issued or such other place as the Competent Authority of CIL/ CMD of Subsidiary Company (as the case may be) at his discretion may determine.

Applicable Law: The contracts shall be interpreted in accordance with the laws of the Union of India.

Signature of Partners of Partnership Firm/ Joint Venture :

- | | | |
|-----------|--------------------------|--------------------|
| 1. | Name of Partner : | Signature : |
| 2. | Name of Partner : | Signature : |
| 3. | Name of Partner : | Signature : |

4. Name of Partner :

Signature :

5. Name of Partner :

Signature :

6.

7.

Note : This CONSENT has to be signed by each Partner of Partnership Firm/ Joint Venture

APPENDIX-14: PROFORMA FOR UNDERTAKING

(To be uploaded by the Bidder on his Letter Head during submission of bid online)

I / We,, Proprietor / Partner /
Legal Attorney / Director / Accredited Representative of M/S.....,
solemnly declare that:

1. I/We am/are submitting Bid for the work..... against
Bid Notice No. Dated..... and I/we offer to execute the work in
accordance with all the terms, conditions and provisions of the bid.

2. Myself/ Our Partners/Directors don't has/have any relative as employee of BCCL/CIL. OR

The details of relatives of Myself/Our Partners/ Directors working as employee of BCCL/CIL

- a. Name of the employee
- b. Place of posting
- c. Department
- d. Designation
- e. Type of Relation – Wife / Husband / Father / Step-father / Mother / Step Mother / Son / Step-Son / Son's wife / Daughter / Daughter's Husband / Brother / Step Brother / Sister / Step-Sister.

3. All information furnished by us in respect of fulfilment of eligibility criteria and qualification information of this Bid is complete, correct and true.

4. All copy of documents, credentials and documents submitted along with this Bid are genuine, authentic, true and valid.

5. I/ We hereby authorize department to seek references / clarifications from our Bankers.

6. We hereby undertake that we shall register and obtain license from the competent authority under the contract labor (Regulation & Abolition Act) as relevant, if applicable.

7. *I/We hereby confirm that we have registration with CMPF/EPF Authorities. We shall make necessary payments as required under law.

Or

*I/We hereby undertake that we shall take appropriate steps for registration as relevant under CMPF/EPF authorities, if applicable. We shall make necessary payments as required under law.

*** Delete whichever is not applicable.**

- 8.** ** I/We have not been banned or delisted by any Govt., or Quasi Govt. Agencies or PSUs.

(In case of JV, all partners are covered)

Or

**I / We.....have been banned by the organization named “ _____ ” for a period of..... year/s, effective from to.....

[In case of JV, name(s) of the JV Partner(s)]

**** Delete whichever is not applicable.**

- 9.** I/We have not been debarred by any procuring entity for violation of Preference to Makein India (as applicable) vide Order No. P-45021/2/2017-PP (BE-II) Revision dated 16.09.2020, issued by Govt. of India as amended from time to time (not applicable for works with estimated value put to tender less than 5 lakh).

- 10.** If any information and document submitted is found to be false/ incorrect at any time, department may cancel my/our Bid and action as deemed fit may be taken against me/us, including termination of the contract, forfeiture of all dues including Earnest Money and banning of our firm and all partners of the firm etc.

10(a). I/We are not engaging and will not engage any child labour in any of the activities for which I/We are participating in the tender.

10(b). If it is reported and proved that child labour is engaged by me/us, then I/We will be penalized 10% of the contract value and will be blacklisted.

Date.....

Signature of the Bidder

APPENDIX-15: FORMAT FOR DETAILED PROJECT SCHEDULE

(to be furnished by the Bidder in the Bid in form of Gantt Chart or PERT Chart)

Sl. No.	Activity	Weeks							
		W1	W2	W3	Wn
1.									
2.									
3.									

The Bidder shall ensure that the Project COD is achieved within 300 days (i.e. 10months) from the date of commencement.

APPENDIX-16: VALID DIGITAL SIGNATURE CERTIFICATE (DSC)

(TO BE SUBMITTED IN THE LETTER HEAD OF BIDDER)

I/We am/are submitting Bid for the
work.....against Bid Notice No.
..... dated with Digital Signature Certificate (DSC) of
..... (i.e. Own DSC) who is Proprietor/Partner/Legal
Attorney/Director/Accredited Representative of M/S.

(Signature of the Bidder)

OR

**FORMAT FOR AUTHORIZATION OF VALID DIGITAL SIGNATURE CERTIFICATE
(DSC)**

(On NON JUDICIAL STAMP PAPER)

(POWER OF ATTORNEY)

I/We am/are submitting Bid for the
work.....against NIT No. dated
..... with Digital Signature Certificate (DSC) of..... (i.e.
Other DSC) whose DSC has been mapped against name of the bidder who has been authorized to bid on
behalf of bidder

Name, Signature & Seal of the person who has signed Letter of Bid and is authorizing the DSC Holder for online bidding.	Name & Signature of the DSC Holder having DSC mapped against name of the bidder and authorized for online bidding
---	---

APPENDIX-17: GUIDELINES FOR BANNING OF BUSINESS

CIL and its Subsidiary Companies shall follow the following guidelines for effecting 'Banning of Business' with a contracting entity in respect of Works and Services Contracts.

1. Observance of Principle of Natural Justice before banning the business dealings with any contracting entity.

2. The contracting entity may be banned in the following circumstances:-

- i)** If bidder backs out after notification of opening of price bid and if that bidder is found to be L-1.
- ii)** If L-1 bidder fails to submit PSD, if any and/or fails to execute the contract within stipulated period.
- iii)** If L-1 bidder fails to start the work on scheduled time.
- iv)** In case of failure to execute the work as per mutually agreed work schedule.
- v)** Continued and repeated failure to meet contractual Obligations:
 - a.** In case of partial failure on performance, agency shall be banned from future participation in tenders keeping his present contract alive.
 - b.** On termination of contract.
- vi)** Willful suppression of facts or furnishing of wrong information or manipulated or forged documents by the Agency or using any other illegal/unfair means.
- vii)** Formation of price cartels with other contractors with a view to artificially hiking the price.
- viii)** The contractor fails to maintain/repair/redo the work up to the expiry of performance guarantee period, when it is specifically brought to his notice.
- ix)** Contractor fails to use Mobilization advance given to him for the purpose it was intended.
- x)** Contractor fails to renew the securities deposited to the department.
- xi)** The contractor fails to rectify any lapse(s) in quality of the work done within defect liability period.
- xii)** Transgression of any clause(s) relating to Contractor's obligation defined in the Integrity Pact wherever such Pact exists.
- xiii)** Any other breach of Contract or misdeed which may cause financial loss or commercial disadvantage to the Company.

3. Such 'Banning of Business', if and when effected, shall be with prospective effect only. The effect of 'Banning of Business' shall be for future tenders from the date of issue of such Order. However, if any contracting entity is banned after online notification of opening of Price Bid, such a ban will not be effective for that work.

4. The banning shall be for a minimum period of two years and shall be effective for the concerned Subsidiary for the tenders invited at Subsidiary level. Similarly, in case of tenders of CIL HQ, banning shall be for CIL HQ. However, if such 'Banning of Business' has to be made effective for entire CIL and its Subsidiaries then approval of Chairman, CIL shall be required.

5. Once a contracting entity is banned, it shall be extended to the constituents of that entity, all partners in case of Joint Venture, all the partners in case of Partnership Firm, owner/proprietor in case of Proprietorship Firm and all the Directors in case of Limited Company. If such banned owner/Proprietor/ Partner/Director make/form

Different Firms/entity and attempts to participate in tenders, the same will not be entertained during the currency of such banning.

6. The above 'Banning of Business' shall be in addition to other penal provisions of NIT/Contract document.

7. Approving Authority: The 'Banning of Business' of a contracting entity shall be done with the approval of the Competent Authority as per the details below:

a) In case the Accepting Authority of the work is Board or Empowered Committee or FDs or CMD of CIL, then the Competent Authority for banning shall be CMD of CIL.

b) In case the Accepting Authority of the work is up to the level of Director of CIL/Subsidiary Company, then the Competent Authority for banning shall be Director of CIL/Subsidiary Company.

8. Appellate Authority shall be one Rank higher than the Competent Authority meant for 'Banning of Business'. In case the banning is done with the approval of CMD of the Subsidiary Company then Chairman, CIL shall be the Appellate authority.

9. Any change on the above may be done with approval of FDs of CIL.

10. All the orders of banning or orders passed in appeal shall be marked to GM (CMC) / Civil / concerned HODs of CIL/Subsidiary Company. Further, all such orders will be uploaded in CIL site as well website of the Subsidiary Company.

11. Efforts shall be made by the concerned Department so that such order is linked to tender portal of Coal India Limited.

APPENDIX-18: FORMAT FOR NO DEMAND CERTIFICATE

NAME OF PACKAGE:

LETTER OF AWARD/ NOA/CONTRACT NO. :

NAME OF CONTRACTOR:

DATED:

We, M/s..... (Contractor) do hereby acknowledge and confirm that we have received the full and final payment due and payable to us from Bharat Coking Coal Ltd (BCCL) in respect of our aforesaid LOA/Contract No..... dated including Amendments, if any, issued by BCCL, to our entire satisfaction and we further confirm that we have no claim whatsoever pending with BCCL under the said Contract.

Notwithstanding any protest recorded by us in any correspondence, document, measurement books, and/or final bills etc., we waive all our rights to lodge any claim or protest in future under this contract.

We are issuing this "NO DEMAND CERTIFICATE" in favor of BCCL. With full knowledge and with our free consent without any undue influence, misrepresentation, coercion etc.

Signature:

Name:

Designation:

Date:

Place:

(This certificate shall be accompanied by the Power of attorney of the signatory)

APPENDIX-19:

PROFORMA OF BANK GUARANTEE FOR MOBILISATION/LUMP -SUM ADVANCE.

M/s. Coal India Limited (with address)

Or.....

(Name of the Subsidiary Company with address).Dear Sir,

In consideration of Coal India Limited/Subsidiary Company having its Registered Office at

(hereinafter called "the Company" which expression shall unless repugnant to the subject or context includes its successors and assigns) having agreed under the terms and conditions of the Contract No..... dated Entered into between Coal India Limited/Subsidiary Company and M/s having

its Registered Office at (Hereinafter called "the Contractor" to make mobilization advance/lump-sum advance to the tune of Rs subject to submission of the Bank Guarantee for equal amount from any Nationalized/ Schedule Bank , WeBank (hereinafter referred to as the said Bank) hiving it is Registered Office at do hereby undertake and agree to pay the Company to the extent of Rs... on demand stating that the amount claimed by the Company is due and payable by the contractor for the reasons of non-refund and or non-recovery of the amount with interest thereon and to unconditionally pay the amount claimed by the company on such demandwithout any demur to the extent aforesaid.

2. We, Bank agree that the Company shall be the sole judge as to whether the said Contractor has failed/neglected in refunding the amount advanced by the Company and/or extent of loss and damages caused to or suffered by the Company on account of the amount advanced not being recovered in full and non-utilization of the said advanced amount or part thereof for the purpose of performance of the contract and interest payable thereon and the decision of the company in this behalf shall be final and binding on us.

3) We, the said Bank further agree that the Guarantee herein contained shall remain in full force and effect up to and any claim received after the said date shall in no case bind the Bank.

4) The Company shall have the fullest liberty without affecting in any way the liability of the Bank underthis guarantee or indemnity from time to time vary any of the terms and conditions of the said contractor to extend the time of performance by the said contractor or to postpone any time and from time totime any of the powers exercisable by it against the said contractor and either to enforce or to forbearfrom enforcing any of the terms and conditions governing the said contract or securities available to the company and the said Bank shall not be released from its liability under these presents.

5. Notwithstanding anything contained herein the liability of the said Bank under this Guarantee isrestricted to Rs and this Guarantee shall come into force from the date hereof and shall remain in full force and effect till unless the written demand or claim under this Guarantee is made

by the Company with us on or before all rights of the Company under this Guarantee shall cease to have any effect and we shall be relieved and discharged our liabilities hereunder.

6. We, the said Bank lastly undertake not to revoke this Guarantee during its currency except with the previous consent of the company in writing and agree that any change in the constitution of the said contractor or the said Bank shall not discharge our liability hereunder.

7. This guarantee issued by Sri..... who is authorized by the
Under jurisdiction of court only.



Bharat Coking Coal Limited

Tender for Design, Engineering, Procurement & Supply, Construction & Erection, Testing, Commissioning, Associated Transmission System and Comprehensive O&M for 5 (Five) Years of 20 MW (AC)/28 MWp (DC) Solar PV Power Plant and connecting Transmission lines at Dugdha Washery, BCCL- Dhanbad



TECHNICAL SPECIFICATIONS

**20 MW (AC) Solar PV Power
Plant at Dugdha, BCCL-
Dhanbad, Jharkhand**

Tender No.

.....

1 | Page



Bharat Coking Coal Limited

Tender for Design, Engineering, Procurement & Supply, Construction & Erection, Testing, Commissioning, Associated Transmission System and Comprehensive O&M for 5 (Five) Years of 20 MW (AC)/28 MWp (DC) Solar PV Power Plant and connecting Transmission lines at Dugdha Washery, BCCL- Dhanbad



VOLUME -II

20 MW (AC) Solar PV Power Plant at Dugdha, BCCL- Dhanbad, Jharkhand

Tender No.

.....

2 | Page



Bharat Coking Coal Limited

Tender for Design, Engineering, Procurement & Supply, Construction & Erection, Testing, Commissioning, Associated Transmission System and Comprehensive O&M for 5 (Five) Years of 20 MW (AC)/28 MWp (DC) Solar PV Power Plant and connecting Transmission lines at Dugdha Washery, BCCL- Dhanbad



TABLE OF CONTENTS

S. No.	Sub Section	Title	Page Nos.
1	VOL-I(A)	Scope of Works	4-20
2	VOL-I(B)	Technical Specifications	21-152
3	VOL-I(C)	Special Technical Specifications	153-155
4	Annexure – A	PV Module Pre-dispatch Inspection Protocol	156-166
5	Annexure – B	FQP and MQP for Civil & MMS works	Appendix A
6	Annexure – C	PG Test Procedure	167-179
7	Annexure – D	Mandatory Spares	180-181
8	Annexure – E	Plant Documentation, Commissioning and Test Procedure	182-197
9	Annexure – F	Drawings (i) Site layout (ii) Chain link fence (iii) Entrance gate	Appendix B



Bharat Coking Coal Limited

Tender for Design, Engineering, Procurement & Supply, Construction & Erection, Testing, Commissioning, Associated Transmission System and Comprehensive O&M for 5 (Five) Years of 20 MW (AC)/28 MWp (DC) Solar PV Power Plant and connecting Transmission lines at Dugdha Washery, BCCL- Dhanbad



SECTION - VII

A. SCOPE OF WORKS

20 MW (AC) Solar PV Power Plant at Dugdha, BCCL- Dhanbad, Jharkhand

Tender No.

.....

4 | Page



Bharat Coking Coal Limited

Tender for Design, Engineering, Procurement & Supply, Construction & Erection, Testing, Commissioning, Associated Transmission System and Comprehensive O&M for 5 (Five) Years of 20 MW (AC)/28 MWp (DC) Solar PV Power Plant and connecting Transmission lines at Dugdha Washery, BCCL- Dhanbad



TABLE OF CONTENTS

1	Project Particulars	6
2	Brief Scope of Work	8
3	Design and Engineering	8
4	Procurement & Supply	10
5	Installation, Testing and Commissioning	12
6	Civil Works	14
7	Statutory Approvals	15
8	Operation and Maintenance	16
9	Operation and Performance Monitoring	19
10	Security Services	20



Bharat Coking Coal Limited

Tender for Design, Engineering, Procurement & Supply, Construction & Erection, Testing, Commissioning, Associated Transmission System and Comprehensive O&M for 5 (Five) Years of 20 MW (AC)/28 MWp (DC) Solar PV Power Plant and connecting Transmission lines at Dugdha Washery, BCCL- Dhanbad



CNUL

1 Project Particulars

Particulars	Description
Design and Engineering	
AC Capacity	20 MW
Minimum DC Capacity	28 MWp
PV Technology	Mono/ Multi Crystalline/ Thin film
Design life of PV Power plant	25 years
O&M period	5 years
Site Location and Land Details	
Latitude & Longitude	Dugdha Washery, Jharkhand 23.44 ° N , 86.15 ° E
Altitude (approx.)	197 mtr.
Available Land Area (approx.)	70 Acre
District	Bokaro
State	Jharkhand
Owner of Project	Bharat Coking Coal Limited
Owner of Land	Bharat Coking Coal Limited
Design Parameters	
Global Horizontal Irradiation (kWh/m ² /month):	1785.5
Diffused Horizontal Irradiation (kWh/m ² /month):	847.6
Average Temperature (° C):	25.9
Wind Velocity (m/s):	2.1
Linke Turbidity (-):	5.926
Relative Humidity (%):	49.0
Electrical Interconnection	
Interconnecting substation	Chandrapura Super Thermal Power Station (CTPS) of DVC
Interconnection voltage level	33 kV

20 MW (AC) Solar PV Power Plant at Dugdha, BCCL- Dhanbad, Jharkhand

Tender No.

.....

6 | Page



Bharat Coking Coal Limited

Tender for Design, Engineering, Procurement & Supply, Construction & Erection, Testing, Commissioning, Associated Transmission System and Comprehensive O&M for 5 (Five) Years of 20 MW (AC)/28 MWp (DC) Solar PV Power Plant and connecting Transmission lines at Dugdha Washery, BCCL- Dhanbad



CNUL



Distance to connecting substation (approx.)	6 kM
Access	
Nearest Urban Area	Bokaro (11 kM)
Nearest Highway	NH- 18 (11 kM)
Nearest Railway Station	Bokaro Steel City (20 kM)
Nearest Domestic Airport	Ranchi (118 kM) Durgapur (143 kM)

Performance Parameters	
Net Electrical Energy Guaranteed Generation (NEEGG)	37.43 MU for first year with allowable degradation of 0.7% in subsequent year's w.r.t. immediate last year.
Capacity Utilization Factor (CUF) at substation end	21.67 %
Other Details	
Water and Power for Construction	To be arranged by the Contractor

20 MW (AC) Solar PV Power Plant at Dugdha, BCCL- Dhanbad, Jharkhand

Tender No.

7 | Page

 <p>Bharat Coking Coal Limited</p>	<p>Tender for Design, Engineering, Procurement & Supply, Construction & Erection, Testing, Commissioning, Associated Transmission System and Comprehensive O&M for 5 (Five) Years of 20 MW (AC)/28 MWp (DC) Solar PV Power Plant and connecting Transmission lines at Dugdha Washery, BCCL- Dhanbad</p>	 <p>CNUL</p>
---	--	---

2 Brief Scope of Work

Scope of Supply and Work includes:

- (a) All design & engineering, procurement & supply of equipment and materials, testing at manufacturers works, multi – level inspections, packing and forwarding, supply, receipt, unloading and storage at site, associated civil works (including fencing work), services, permits, licenses, installation and incidentals, insurance at all stages, erection, testing and commissioning of 20 MW (AC)/ 28 MWp (DC) Grid Interactive Solar PV Power Plant;
- (b) Supply, erection, commissioning and synchronizing of 6 kM (approx.) Transmission System of 33 kV for evacuation of the generated power from Solar Site at Dugdha Washery to Chandrapura Super Thermal Power Station [CTPS] of DVC , and performance demonstration with associated equipment and materials on turnkey basis at Dugdha Washery, BCCL (Bokaro District) at Jharkhand. All the works related to DVC w.r.t. overhead lines and development of bay infrastructure are to be carried out under supervision of DVC and shall meet the drawing standard, GTP formulated by DVC. All the required materials related to above job are to be procured by the successful bidder from DVC approved vendors only, post inspection by DVC QC Department and thereafter issuance of despatch clearance by DVC.
- (c) 5 (Five) years comprehensive operation and maintenance of plant and 33 kV transmission line (6 kM 33 kV OHTL from proposed Solar Site at Dugdha Washery, BCCL to Chandrapura Super Thermal Power Station [CTPS] of DVC).

3 Design and Engineering

- 3.1 The Contractor shall prepare the detailed **Design Basis Report** (DBR) along with relevant standards (with respective clause description), PERT Chart and MDL. The Contractor shall submit a copy to Employer for review and approval prior to detail engineering.
- 3.2 All documents and drawings shall be submitted to the Employer both in soft as well as hard copies (5 nos.) for review and approval. Every drawing shall also be submitted in ‘*.dwg’ format. In case of design calculations done in spread sheet, editable (working) soft copy of the spread sheet shall also be submitted along with ‘pdf’ copies during every submission. The Employer shall return, as suitable, either soft or hard copies to the Contractor with category of approval

<p>20 MW (AC) Solar PV Power Plant at Dugdha, BCCL- Dhanbad, Jharkhand</p>	<p><u>Tender No.</u> <u>.....</u></p>	<p>8 Page</p>
---	---	------------------------



Bharat Coking Coal Limited

Tender for Design, Engineering, Procurement & Supply, Construction & Erection, Testing, Commissioning, Associated Transmission System and Comprehensive O&M for 5 (Five) Years of 20 MW (AC)/28 MWp (DC) Solar PV Power Plant and connecting Transmission lines at Dugdha Washery, BCCL- Dhanbad



CNUL

marked thereon. The drawings/documents shall be approved in any one of the following categories based on nature of the comments/ type of drawing or document.

- Category-I Approved
- Category-II Approved subject to incorporation of comments;
Re-submit for approval after incorporation of comments
- Category-III Not approved;
Re-submit for approval after incorporation of comments
- Category-IV Kept for record/ reference
- Category-IV (R) Re-submit for record/ reference after incorporation of comments

(Note: Approval of document neither relieves the Vendor/ Contractor of his contractual obligations and responsibilities for correctness of design, drawings, dimensions, quality & specifications of materials, weights, quantities, assembly fits, systems/ performancerequirement and conformity of supplies with Technical Specifications, Indian statutory laws as may be applicable, nor does it limit the Employer/ Purchaser’s rights under thecontract)

3.3 Submission of basic design data, design documents, drawings and engineering information including GTP and test reports to Employer or its authorized representative for review and approval in hard copy and soft copy from time to time as per project schedule. The documents typically include, but not limited to, the following:

- Solar insolation data and basis for generation
- Detailed technical specifications (GTP) of all the equipment
- General arrangement and assembly drawings of all major equipment
- Schematic diagram for entire electrical system (DC, AC and auxiliary systems)
- GTP & G.A. drawings for all types of structures/ components, 33 kVswitchgears (as applicable) & other interfacing panels
- Test reports (for type, routine and acceptance tests)
- Relay setting charts
- Design calculations and sheets (licenced software as well as design templates)
- Geo technical investigation data and Topographical survey report including topographical survey data in digital format (Excel file) and Contour plan of the area.
- GA drawings of the entire project including equipment rooms/ inverter control rooms, office cum control room, roads, storm water drainage, sewage networks, security gate, fire



Bharat Coking Coal Limited

Tender for Design, Engineering, Procurement & Supply, Construction & Erection, Testing, Commissioning, Associated Transmission System and Comprehensive O&M for 5 (Five) Years of 20 MW (AC)/28 MWp (DC) Solar PV Power Plant and connecting Transmission lines at Dugdha Washery, BCCL- Dhanbad



protection system, perimeter fencing, transformer yard fencing etc.

- Transmission line drawings and erection plans as per DISCOM/ STU guidelines
- Quality assurance plans for manufacturing (MQP), Standard Operating procedure(SOP) and field activities (FQP)
- Detailed site EHS plan, fire safety & evacuation plan and disaster management plan.
- Detailed risk assessment and mitigation plan.
- O&M Instruction's and maintenance manuals for major equipment
- As-built drawings / documents and deviation list from good for construction (GFC)

3.4 Estimation of the plant generation based on Solar Radiation and other climatic conditions prevailing at site.

3.5 Design of associated civil, structural, electrical & mechanical auxiliary systems includes preparation of single line diagrams and installation drawings, manuals, electrical layouts, erection key diagrams, electrical and physical clearance diagrams, design calculations for Earth-mat, Bus Bar & Spacers indoor and outdoor lighting/ illuminationetc., GTP and GA drawings for the major equipment including transmission line, designbasis & calculation sheets, and other relevant drawings and documents required for engineering of all facilities within the periphery to be provided under this contract.

3.6 All drawings shall be fully corrected to match with the actual "As – Built" site conditionsand submitted to Employer after commissioning of the project for record purpose. All as-built drawings must include the Good for Construction deviation list.

4 Procurement & Supply

4.1 Adequate capacity of solar PV modules with minimum DC capacity of **28 MWp**.

4.2 Module Mounting Structure (MMS) with necessary hardware suitable for mounting PV modules.

4.3 String Monitoring Unit along with mounting structure in case of central inverterconfiguration.

4.4 Solar cables along with lugs, glands, ferrules, straight/Y-connectors and other materialsrequired proper cable termination at both the ends.

4.5 Power Conditioning Units (Central / String) of suitable rating.

4.6 Step-up transformers (inverter duty) as per inverter manufacturer requirements.



Bharat Coking Coal Limited

Tender for Design, Engineering, Procurement & Supply, Construction & Erection, Testing, Commissioning, Associated Transmission System and Comprehensive O&M for 5 (Five) Years of 20 MW (AC)/28 MWp (DC) Solar PV Power Plant and connecting Transmission lines at Dugdha Washery, BCCL- Dhanbad



- 4.7 Indoor/Outdoor switchgear panels including Vacuum Circuit Breakers, Current Transformers, Voltage Transformers, Relays and other accessories for complete protection.
- 4.8 Auxiliary transformers of adequate rating for plant internal consumption.
- 4.9 AC distribution panels with sufficient number of output feeders required for auxiliary power distribution.
- 4.10 DC and AC cables of appropriate sizes with termination kits.
- 4.11 LT Power and Control Cables including end terminations and other required accessories.
- 4.12 ABT meters with all necessary metering rated CTs and PTs at the plant take off point as well as at the substation as per CEA Metering Regulation 2006 as amended time to time and state metering code.
- 4.13 Supervisory Control and Data Acquisition (SCADA) system for remote monitoring/control of plant facilities along with required communication cables.
- 4.14 Data Acquisition System and communication medium for transfer of real time data from plant to SLDC as per SLDC specifications.
- 4.15 Uninterrupted Power Supply (UPS) with battery bank of sufficient capacity for critical loads as specified.
- 4.16 Earth strip/cables, earth electrodes, earth enhancing compound and all other associated materials for complete earthing of the plant as per the relevant standards.
- 4.17 Lightning Protection System for entire plant area.
- 4.18 Testing instruments as specified.
- 4.19 Mandatory spares as specified in Annexure – D.
- 4.20 CCTV camera system along with monitoring station for plant surveillance.
- 4.21 Fire detection and protection system in building, inverter station, transformer yard and switchyard.
- 4.22 Weather monitoring station shall include but not be limited to the following:
 - Pyranometer / Albedometer
 - Ultrasonic Anemometer (wind speed and direction)
 - Temperature Sensor – Ambient and module surface
 - Power source to all sensors
 - Data Logger
- 4.23 All safety equipment including PPE, mats etc. for safe working environment.



Bharat Coking Coal Limited

Tender for Design, Engineering, Procurement & Supply, Construction & Erection, Testing, Commissioning, Associated Transmission System and Comprehensive O&M for 5 (Five) Years of 20 MW (AC)/28 MWp (DC) Solar PV Power Plant and connecting Transmission lines at Dugdha Washery, BCCL- Dhanbad



- 4.24** Transmission towers / poles suitable for required voltage level from plant take off point to the designated substation along with conductors, insulators, earth rods and other associated accessories or cables and other associated accessories as per Technical Specifications and DISCOM / TRANSCO requirements.
- 4.25** Obtaining Right of Way (RoW) for transmission line / cable from Solar PV plant till the interconnecting substation including all applicable documentation and compensation, if any.
- 4.26** Protection, metering and communication equipment and other associated equipment / materials required for evacuation at the interconnecting substation as per DISCOM / TRANSCO requirements.
- 4.27** Materials and accessories, which are required for satisfactory and trouble-free operation and maintenance of the above equipment like module cleaning system, supply of spares for all equipment, supply of tools and tackles etc.,
- 4.28** Any other equipment / material not mentioned but required to complete the Solar Power Plant facilities in all respect.

5 Installation, Testing and Commissioning

The scope of installation, testing and commissioning for the plant facilities shall include, but not limited, to the following.

- 5.1** Installation of PV Modules on Module Mounting Structures and interconnection of PV Modules.
- 5.2** Laying of solar cables through HDPE conduits underground / along cable trays from PV Modules to SMU / PCU along with termination at both the ends.
- 5.3** Installation, Testing and Commissioning of String Monitoring Units.
- 5.4** Laying of DC cables underground / along cable trays from SMU to PCU along with termination at both the ends (in case of central inverter configuration).
- 5.5** Installation, Testing and Commissioning of Power Conditioning Units.
- 5.6** Installation, Testing and Commissioning of inverter-duty transformers.
- 5.7** Installation, Testing and Commissioning of switchgear panels.
- 5.8** Laying of 1.1 kV AC cables along underground / cable trays from PCU to inverter-duty transformer along with termination at both the ends.
- 5.9** Laying of HT AC cables underground / along cable trays from inverter-duty transformer to switchgear panel along with termination at both the ends.



Bharat Coking Coal Limited

Tender for Design, Engineering, Procurement & Supply, Construction & Erection, Testing, Commissioning, Associated Transmission System and Comprehensive O&M for 5 (Five) Years of 20 MW (AC)/28 MWp (DC) Solar PV Power Plant and connecting Transmission lines at Dugdha Washery, BCCL- Dhanbad



- 5.10** Laying of HT AC cables underground / along cable trays from switchgear panel at Local Control Room / field to switchgear panel at Main Control Room along with termination at both the ends.
- 5.11** Installation, Testing and Commissioning of ABT meters with all necessary metering rated CTs and PTs at Main Control Room as per CEA Metering Regulation 2006 as amended time to time and state metering code.
- 5.12** Installation, Testing and Commissioning of auxiliary power supply system consisting of auxiliary transformers, AC distribution boards, AC LT cables and related accessories.
- 5.13** Installation, Testing and Commissioning of suitable communication system for interfacing SMU, PCU, Transformer, Switchgear panel, ABT meter, UPS, Fire alarm panel, WMS and other plant equipment with SCADA.
- 5.14** Installation, Testing and Commissioning of data acquisition system from SPV plant to SLDC along with communication system as required by SLDC.
- 5.15** Installation, Testing and Commissioning of Uninterrupted Power Supply (UPS) with battery bank.
- 5.16** Earthing of PV Modules, Module Mounting Structures, SMU, PCU, switchgear panels and all other electrical equipment.
- 5.17** Installation of lightning protection system for entire plant facilities.
- 5.18** Installation of indoor & outdoor illumination system including all required accessories and laying of power supply cables.
- 5.19** Installation, Testing and Commissioning of Weather Monitoring Station along with laying of required power supply and communication cables.
- 5.20** Installation of CCTV cameras on strategic locations including all required accessories, laying of power/communication cables and installation of monitoring station and other associated equipment.
- 5.21** Installation of fire detection and fire protection system for buildings, transformer yard, switchyard and pooling sub-station.
- 5.22** Pre-commissioning checks and tests for all equipment.
- 5.23** Synchronization and Commissioning of plant as per DISCOM / TRANSCO requirements.
- 5.24** Installation, Testing and Commissioning of Transmission line / cable from plant take off point to the interconnecting substation and bay at substation shall be in the scope of EPC Contractor. The EPC Contractor shall maintain the OHTLs during O&M period of 5 years at the cost of



Bharat Coking Coal Limited

Tender for Design, Engineering, Procurement & Supply, Construction & Erection, Testing, Commissioning, Associated Transmission System and Comprehensive O&M for 5 (Five) Years of 20 MW (AC)/28 MWp (DC) Solar PV Power Plant and connecting Transmission lines at Dugdha Washery, BCCL- Dhanbad



EPC Contractor. Safety, security of the said transmission line upto 5 years O&M period will be the sole responsibility of the EPC Contractor.

5.25 Any other works related to installation, testing and commissioning not mentioned but required to complete the Solar Power Plant facilities in all respect.

6 Civil Works

6.1 Conducting geotechnical investigation and topographical survey of the plant area. The lands are covered with small trees, seasonal crops and long bushes. Clearance of such trees and bushes shall be under the scope of Owner.

6.2 Earthwork for site grading, cutting, filling, levelling & compaction of land.

6.3 Construction of approach roads, access roads, internal roads and peripheral roads.

6.4 Construction of storm water drainage and sewage network including rainwater harvesting mechanism.

6.5 Construction of chain link fence along the plant boundary and main gate(s).

6.6 Construction of foundation for Module Mounting Structures (MMS) and erection of MMS.

6.7 Construction of Local Control Rooms (in case of indoor PCU/Switchgear).

6.8 Construction of Master Control Room along with requisite furniture, air-conditioning and other equipment / material as per the specifications.

6.9 Construction of foundation and erection of mounting structure for String Monitoring Unit.

6.10 Foundation for inverter (in case of outdoor inverter), inverter-duty transformer, switchgear panel (in case of outdoor panel), auxiliary transformer and metering panel.



6.11 Construction of foundation for lightning mast, lighting poles, CCTV poles, weather monitoring station and other equipment.

6.12 Construction of underground tanks and plumbing network for drinking water and cleaning of PV Modules.

6.13 Suitable arrangement of water to cater to day-to-day requirement of drinking water and permanent water supply for module cleaning and other needs of SPV power plant during entire O&M period.

6.14 Construction of closed outdoor storage shed of area sufficient enough for storing spare PV Modules, cable drums, transformer oil tanks etc. at each location.

6.15 Construction of foundation for transmission tower / pole as per DISCOM / TRANSCO

 <p>Bharat Coking Coal Limited</p>	<p>Tender for Design, Engineering, Procurement & Supply, Construction & Erection, Testing, Commissioning, Associated Transmission System and Comprehensive O&M for 5 (Five) Years of 20 MW (AC)/28 MWp (DC) Solar PV Power Plant and connecting Transmission lines at Dugdha Washery, BCCL- Dhanbad</p>	 <p>CNUL</p>
---	--	---

requirements from Solar PV Plant end till interconnecting substation.

- 6.16** Construction of equipment foundation at interconnecting substation as per DISCOM / TRANSCO requirements.
- 6.17** All approvals, equipment, items and works, which are not otherwise specifically mentioned in this document but are required for successful completion of the work in all aspects, including construction, commissioning, O&M of Solar PV Power Plant and guaranteed performance are deemed to be included in the scope of the contractor.

7 Statutory Approvals

- 7.1** Obtaining statutory approvals / clearances / compliances on behalf of the Employer from various Government Departments, not limited to, the following:
 - Pollution control board clearance, if required
 - Mining Department, if required
 - Forest Department, if required
 - All other approvals as and when necessary for setting up of a solar power plant including CEIG / CEA, power evacuation, railways, PTCC power line crossing, panchayat, NHAI etc. as per the suggested guidelines.
- 7.1.1** All statutory approvals / permissions and/or No Objection Certificates (NoC) etc. from DISCOM / TRANSCO for obtaining connectivity at the substation as per Project Particulars provided above.
- 7.1.2** All other statutory approvals and permissions and their respective compliances, not mentioned specifically but are required to carry out hassle free Construction and O&M of the plant.
- 7.1.3** Adequate and seamless insurance coverage during EPC and O&M period to mitigate all risks related to construction and O&M of the plant to indemnify the Employer.
- 7.2** The Contractor shall comply with the provision of all relevant acts of Central or State Governments including payment of Wages Act 1936, Minimum Wages Act 1948, Employer's Liability Act 1938, Workmen's Compensation Act 1923, Industrial Dispute Act 1947, Maturity Benefit Act 1961, Mines Act 1952, Employees State Insurance Act 1948, Contract Labour (Regulations & Abolishment) Act 1970, Electricity Act 2003, GridCode, Metering Code, MNRE guidelines or any modification thereof or any other law relating thereto and rules made there under or amended from time to time.

<p>20 MW (AC) Solar PV Power Plant at Dugdha, BCCL- Dhanbad, Jharkhand</p>	<p><u>Tender No.</u> <u>.....</u></p>	<p>15 Page</p>
---	---	-------------------------



Bharat Coking Coal Limited

Tender for Design, Engineering, Procurement & Supply, Construction & Erection, Testing, Commissioning, Associated Transmission System and Comprehensive O&M for 5 (Five) Years of 20 MW (AC)/28 MWp (DC) Solar PV Power Plant and connecting Transmission lines at Dugdha Washery, BCCL- Dhanbad



CNUL

8 Operation and Maintenance

- 8.1** Total Operation & Maintenance of the SPV Plant shall be with the Contractor, after operational acceptance of the plant till culmination of the O&M period and shall include deployment of engineering personnel, technicians and security personnel. The EPC Contractor shall also maintain the OHTLs during O&M period of 5 years at the cost of EPC Contractor. Safety, security of the said transmission line upto 5 years O&M period will be the sole responsibility of the EPC Contractor.
- 8.2** To provide a detailed training plan for all O&M procedures to Employer’s nominated staff, which shall have prior approval from the Employer.
- 8.3** Employ and coordinate the training of contractors’ personnel who will be qualified and experienced to operate and monitor the facility and to coordinate operations of the facility with the grid system.
- 8.4** Discharge obligations relating to retirement/ Superannuating benefits to employees or any other benefit accruing to them in the nature of compensation, profit in lieu / in addition to salary, etc. for the period of service with the contractor, irrespective continuance of employees with the project as employees of Contractor, after conclusion of O&M period.
- 8.5** To maintain accurate and up-to-date operating logs, records and monthly Operation & Maintenance reports at the facility. Contractor shall keep the measured daily data at regular intervals and provide the same to Employer in electronic form, compatible in CSV format. The right to use the data shall remain with the Employer.
- 8.6** The Contractor shall establish forecasting tools for submitting schedule and comply with applicable Forecasting, Scheduling and Deviation Settlement Regulations. The scope under this Clause shall also include establishing and maintaining forecasting tools and appointment of QCA/Aggregator, if required. % Error (Deviation) shall be calculated as per the said regulations and DSM Charges in case of deviation beyond the permissible limits shall be borne by the Contractor.



Bharat Coking Coal Limited

Tender for Design, Engineering, Procurement & Supply, Construction & Erection, Testing, Commissioning, Associated Transmission System and Comprehensive O&M for 5 (Five) Years of 20 MW (AC)/28 MWp (DC) Solar PV Power Plant and connecting Transmission lines at Dugdha Washery, BCCL- Dhanbad



CNUL

- 8.7** Procurement of spare parts, overhaul parts, tools & tackles, equipment, consumables, etc. required for smooth operation and maintenance of the plant as per prudent/ standard utility practices, OEM recommendations and warranty clauses for the entire O&M period.
- 8.8** To upkeep all administrative offices, roads, tool room, stores room, equipment in clean, green and workable conditions.
- 8.9** To carry out periodic overhauls or maintenance required as per the recommendations of the original equipment manufacturer (OEM) and to furnish all such periodic maintenance schedules at the time of plant commissioning/ start of O&M contract.
- 8.10** Handover the system to maintain an inventory of spare parts, tools, equipment, consumables and supplies for the facility's operation along-with required details of recommended spares list with all associated information regarding replacement records, supplier details, tentative cost, storage details, specifications on the basis of replacement frequency and mean time between failures and mean time to restore at the culmination of penultimate year under O&M period.
- 8.11** Availability of vehicles for Employer staff during construction and O&M period as per requirement may be ensured, failing which Employer shall have full right for alternate arrangement at the risk & cost of the contractor.
- 8.12** The contractor shall be responsible for all the required activities for the successful running, committed energy generation & maintenance of the Solar Photovoltaic Power Plant covering:
 - Deputation of qualified and experienced engineers and technicians at the facility.
 - Deputation of Security personnel for the complete security of plant.
 - Successful running of Solar Power Plant for committed energy generation.
 - Co-ordination with STU/SLDC/other statutory organizations as per the requirement on behalf of Employer for Joint Metering Report (JMR), furnishing generations schedules as per requirement, revising schedules as necessary and complying with grid requirements.
 - Monitoring, controlling, troubleshooting maintaining of logs & records, registers.
 - Furnishing generation data monthly to Employer/Owner by 1st week of every month for the previous month to enable Employer raise commercial bills on consumers.
 - Periodic cleaning of solar modules as approved by the Employer and water quality as per the recommendations of OEM.
 - Replacement of Modules, Invertors/PCU's and other equipment as and when required during the O&M period without additional cost to Employer.

20 MW (AC) Solar PV Power Plant at Dugdha, BCCL- Dhanbad, Jharkhand

Tender No.
.....



Bharat Coking Coal Limited

Tender for Design, Engineering, Procurement & Supply, Construction & Erection, Testing, Commissioning, Associated Transmission System and Comprehensive O&M for 5 (Five) Years of 20 MW (AC)/28 MWp (DC) Solar PV Power Plant and connecting Transmission lines at Dugdha Washery, BCCL- Dhanbad



- 8.13** Continuous monitoring of the performance of Solar Power Plant and regular maintenance of the whole system including Modules, PCU’s, transformers, overhead line, outdoor/indoor panels/ kiosks etc. are necessary for extracting and maintaining the maximum energy output from the Solar Power Plant.
- 8.14** Preventive and corrective O&M of the Solar Photovoltaic Power Plant including supply of spares, consumables, wear and tear, overhauling, replacement of damaged modules, inverters, battery packs/modules, PCUs and insurance covering all risks (Fire& allied perils, earth quake, terrorists, burglary and others) as required.
- 8.15** The period of Operation and Maintenance will be deemed to commence from the date of completion of performance demonstration/Operational acceptance and successively the complete Solar Photovoltaic Power Plant to be handed over to the O&M contractor for operation and maintenance of the same. O&M contract shall further be extended on the mutually agreed terms and conditions for the mutually agreed period.
- 8.16** All the equipment required for Testing, Commissioning and O&M for the healthy operation of the Plant must be calibrated, time to time, from the NABL accredited labs and the certificate of calibration must be provided prior to its deployment.
- 8.17** The Contractor shall ensure that all safety measures are taken at the site to avoid accidents to his or his sub-contractor or Employer’s Workmen. This will include procurement of all safety gadgets during Construction and O&M period including but not limited to, rubber mats of appropriate grade, PPE, rubber gloves and suitable shoes etc.



Bharat Coking Coal Limited

Tender for Design, Engineering, Procurement & Supply, Construction & Erection, Testing, Commissioning, Associated Transmission System and Comprehensive O&M for 5 (Five) Years of 20 MW (AC)/28 MWp (DC) Solar PV Power Plant and connecting Transmission lines at Dugdha Washery, BCCL- Dhanbad



CNUL

9 Operation and Performance Monitoring

- 9.1** Operation part consists of deputing necessary manpower necessary to operate the Solar Photovoltaic Power Plant at the full capacity. Operation procedures such as preparation to starting, running, routine operations with safety precautions, monitoring etc., shall be carried out as per the manufacturer’s instructions to have trouble free operation of the complete system.
- 9.2** Daily work of the operation and maintenance in the Solar Photovoltaic Power Plant involves periodic cleaning of Modules including periodic tilt angle change as and when required, logging the voltage, current, power factor, power and energy output of the Plant at different levels. The operator shall also note down time/ failures, interruption in supply and tripping of different relays, reason for such tripping, duration of such interruption etc. The other task of the operators is to check battery voltage-specific gravity and temperature. The operator shall record monthly energy output, down time, etc.
- 9.3** Earth resistance of Plant as well as individual earth pit is to be measured and recorded every month. If the earth resistance is high (compared to standards) suitable action is to be taken to bring down the same.
- 9.4** A maintenance record is to be maintained by the operator/ O&M-in-charge to record the regular maintenance work carried out as well as any breakdown maintenance along with the reasons for the breakdowns and steps taken to attend the breakdown, duration of the breakdown etc.
- 9.5** The Preventive Maintenance Schedules will be drawn such that some of the jobs other than breakdown, which may require comparatively long stoppage of the Power Plant, shall be carried out preferably during the non-sunny days or evenings. Prior information shall be provided to the Employer for such preventive maintenance prior to start.
- 9.6** The Contractor will attend to any breakdown jobs immediately for repair/ replacement/ adjustments and complete at the earliest working round the clock. During breakdowns (not attributable to normal wear and tear) in O&M period, the Contractor shall immediately report the accidents, if any, to the Employer showing the circumstances under which it happened and



Bharat Coking Coal Limited

Tender for Design, Engineering, Procurement & Supply, Construction & Erection, Testing, Commissioning, Associated Transmission System and Comprehensive O&M for 5 (Five) Years of 20 MW (AC)/28 MWp (DC) Solar PV Power Plant and connecting Transmission lines at Dugdha Washery, BCCL- Dhanbad



CNUL

the extent of damage and/or injury caused.

- 9.7 The contractor shall at his own expense provide all amenities to his workmen as per applicable laws and rules.
- 9.8 If negligence / mal operation of the contractor's operator results in failure of equipment, such equipment should be repaired/replaced by the contractor free of cost.

10 Security Services

- 10.1 The contractor has to arrange proper security system including deputation of security personnel at his own cost for the check vigil for the Solar Power Plant for the complete scope of works including comprehensive O&M period.
- 10.2 The security staff may be organized to work on suitable shift system; proper checking & recording of all incoming & outgoing materials vehicles shall be maintained. Any occurrence of unlawful activities shall be informed to Employer immediately. A monthly report shall be sent to Employer on the security aspects.
- 10.3 Any other activities required for completion of project, but not specified in the above shall be in the scope of contractor. The Contractor must provide the BOM of the plant as per the design during the time of submission of design basis report. The detailed technical specifications of major equipment to be followed strictly and are described in the technical specification section.



Bharat Coking Coal Limited

Tender for Design, Engineering, Procurement & Supply, Construction & Erection, Testing, Commissioning, Associated Transmission System and Comprehensive O&M for 5 (Five) Years of 20 MW (AC)/28 MWp (DC) Solar PV Power Plant and connecting Transmission lines at Dugdha Washery, BCCL- Dhanbad



SECTION - VII

B. TECHNICAL SPECIFICATIONS

20 MW (AC) Solar PV Power Plant at Dugdha, BCCL- Dhanbad, Jharkhand

Tender No.
.....

21 | Page



Bharat Coking Coal Limited

Tender for Design, Engineering, Procurement & Supply, Construction & Erection, Testing, Commissioning, Associated Transmission System and Comprehensive O&M for 5 (Five) Years of 20 MW (AC)/28 MWp (DC) Solar PV Power Plant and connecting Transmission lines at Dugdha Washery, BCCL- Dhanbad



TABLE OF CONTENTS

A Design Philosophy 26

B Electrical System..... 27

 1 Photovoltaic Modules 27

 2 String Monitoring Unit..... 33

 3 Solar and DC Cables 34

 4 Power Conditioning Unit 36

 5 Inverter Transformer and Auxiliary Transformer 42

 6 HT Switchgear 47

 7 AC Cables 58

 8 Auxiliary Supply System 60

 9 LT Switchgear..... 61

 10 Uninterrupted Power Supply..... 65

 11 Battery and Battery Charger 67

 12 Earthing..... 70

 13 Lightning Protection System..... 73

 14 Communication Cables 74

 15 SCADA 75

 16 Illumination..... 82

 17 Weather Monitoring System 86

 18 CCTV Camera 88

 19 Fire Alarm System 89

 20 Testing Instruments..... 90

 21 Power evacuation system 94

C Civil, Mechanical and Plumbing Works 94

 1 General Requirement 94

 2 Topographical Survey 96

 3 Geotechnical Investigations 98

 4 Other Investigations 101

 5 Area Grading and Land Development 102



Bharat Coking Coal Limited

Tender for Design, Engineering, Procurement & Supply, Construction & Erection, Testing, Commissioning, Associated Transmission System and Comprehensive O&M for 5 (Five) Years of 20 MW (AC)/28 MWp (DC) Solar PV Power Plant and connecting Transmission lines at Dugdha Washery, BCCL- Dhanbad



CNUL

6	Roads.....	104
7	Surface/ Area drainage.....	106
8	Peripheral boundary Wall/Fence.....	108
9	Plant Layout	110
10	Design Loads	111
11	Foundations (General).....	114
12	MMS Foundation	115
13	Module Mounting Structure (MMS).....	119
14	Concrete Works.....	123
15	Miscellaneous Steel Works	124
16	Buildings and Plinth for Open Installations	124
17	Flooring, Skirting and Dado.....	133
18	Doors and Windows	134
19	Roofing	135
20	Plinth protection and drain.....	136
21	Plinth filling for buildings.....	136
22	Anti- termite Treatment	136
23	Plumbing & Sanitary Works	137
24	Painting & Other Finishes.....	137
25	Air conditioning & Ventilation for MCR and Other Buildings	138
26	Fire Extinguishers	138
27	Sand buckets	138
28	Sign Boards and Danger Boards	139
29	Masonry Work	139
30	Plastering, Pointing & Coping Works.....	140
31	Building Water Supply & Plumbing Works	140
32	Sewage Treatment facility	140
33	Pipe & Cable Trenches	141
34	Transformer Yard Civil Works	141
35	Potable Water Supply & PV Module Cleaning System.....	143
36	Underground Water Tank	144

20 MW (AC) Solar PV Power Plant at Dugdha, BCCL- Dhanbad, Jharkhand

Tender No.

.....

23 | Page



Bharat Coking Coal Limited

Tender for Design, Engineering, Procurement & Supply, Construction & Erection, Testing, Commissioning, Associated Transmission System and Comprehensive O&M for 5 (Five) Years of 20 MW (AC)/28 MWp (DC) Solar PV Power Plant and connecting Transmission lines at Dugdha Washery, BCCL- Dhanbad



CNUL

37 Transmission Line Structures..... 145

38 Miscellaneous structures 145

D Quality Assurance and Inspection of Civil Works..... 146

1 Introduction..... 146

2 QA and QC Manpower 147

3 Laboratory and Field Testing..... 148

4 Sampling and Testing of Construction Materials..... 149

5 Purchase and Service 149

6 Field Quality Plan 150

7 General QA Requirements 150

E Performance Measurement Procedure 152

1 Performance Ratio (PR) 152

2 Capacity Utilization Factor (CUF)..... 152



Bharat Coking Coal Limited

Tender for Design, Engineering, Procurement & Supply, Construction & Erection, Testing, Commissioning, Associated Transmission System and Comprehensive O&M for 5 (Five) Years of 20 MW (AC)/28 MWp (DC) Solar PV Power Plant and connecting Transmission lines at Dugdha Washery, BCCL- Dhanbad



DISCLAIMER:

1. Though adequate care has been taken while preparing the Bidding documents, the Bidders/Applicants shall satisfy themselves that the document is complete in all respects. Intimation of any discrepancy shall be given to this office immediately. If no intimation is received from any Bidder within twenty (20) days from the date of notification of NIT/ Issue of the NIT documents, it shall be considered that the NIT documents are complete in all respects has been received by the Bidder.
2. CIL Navikarniya Urja Limited (CNUL), the Tender Inviting Authority, reserves the right to modify, amend or supplement this NIT documents including all formats and Annexures.
3. While this bidding documents have been prepared in good faith, neither Employer or its authorized representatives nor their employees or advisors make any representation or warranty, express or implied, or accept any responsibility or liability, whatsoever, in respect of any statements or omissions herein, or the accuracy, completeness or reliability of information, and shall incur no liability under any law, statute, rules or regulations as to the accuracy, reliability or completeness of this bidding documents, even if any loss or damage is caused by any act or omission on their part.
4. The specifications mentioned for all the equipment which include Solar modules, PCU, combiner boxes, DC cables, module mounting structures, transformer, CT, PT, LT/ HT cables, interfacing panels, switch gears & other associated equipment etc., to complete the power generation and evacuation to the designated substation, in the present bidding documents are for the **reference** only. It is subject to revise/ alter as per the design/ planning/good engineering practices etc., to be carried out by the selected bidder, to the satisfaction of the Employer or its authorized representatives. It is advised that the bidders must satisfy himself with the prevailing site conditions before design/ plan. The design must be optimized as per the site conditions and directed to achieve the maximum output from the installed capacity at all times. Moreover, the components not separately mentioned, but are required to complete the plant for operation is also included in the scope of bidder and shall be vetted by the Employer or its authorized representatives.



Bharat Coking Coal Limited

Tender for Design, Engineering, Procurement & Supply, Construction & Erection, Testing, Commissioning, Associated Transmission System and Comprehensive O&M for 5 (Five) Years of 20 MW (AC)/28 MWp (DC) Solar PV Power Plant and connecting Transmission lines at Dugdha Washery, BCCL- Dhanbad



CNUL

A Design Philosophy

1 The main objective of the design philosophy is to construct the plant with in-built Quality and appropriate redundancy to achieve high availability and reliability with minimum maintenance efforts. In order to achieve this, the following principles shall be adopted while designing the system.

- 1.1** Adequate capacity of SPV modules, PCUs, Junction boxes etc. to ensure generation of power as per design estimates. This will be done by applying liberal de-rating factors for the array and recognizing the efficiency parameters of PCUs, transformers, conductor losses, system losses, site conditions etc.
- 1.2** Use of equipment and systems with proven design and performance that have high availability track records under similar service conditions.
- 1.3** Selection of the equipment and adoption of a plant layout to ensure ease of maintenance.
- 1.4** Strict compliance with approved and proven quality assurance (QA) systems and procedures during different stages of the project, starting from sizing, selection of make, shipment, storage (at site), during erection, testing and commissioning.
- 1.5** Proper monitoring of synchronization and recording, to ensure availability of power to the grid.
- 1.6** The plant instrumentation and control system should be designed to ensure high availability and reliability of the plant to assist the operators in the safe and efficient operation of the plant with minimum effort.
- 1.7** It should also provide the analysis of the historical data and help in the plant maintenance people to take up the plant and equipment on predictive maintenance.
- 1.8** System design shall have intelligent protection mechanism which may include very fast responsive microprocessor-based relays etc., so that any disturbance from the grid will not cause any damage to the equipment of the Solar Power Plant.
- 2** The basic and detailed engineering of the plant shall aim at achieving high standards of operational performance especially considering following:
 - 2.1** SPV power plant should be designed to operate satisfactorily in synchronization with the grid within permissible limits of high voltage and frequency fluctuation conditions. It is also extremely important to safeguard the system during major disturbances, internal and external



Bharat Coking Coal Limited

Tender for Design, Engineering, Procurement & Supply, Construction & Erection, Testing, Commissioning, Associated Transmission System and Comprehensive O&M for 5 (Five) Years of 20 MW (AC)/28 MWp (DC) Solar PV Power Plant and connecting Transmission lines at Dugdha Washery, BCCL- Dhanbad



surge conditions while ensuring safe operation of the plant.

- 2.2** Fixed tilt / Seasonal tilt / Single-axis tracking of SPV arrays.
- 2.3** Shadow free plant layout to ensure minimum losses in generation during the day time.
- 2.4** Higher system voltage and lower current options to be followed to minimise ohmic losses.
- 2.5** Selection of PCUs with proven reliability and minimum downtime. Ready availability of requisite spares.
- 2.6** Careful logging of operational data / historical information from the Data Monitoring Systems, and periodical analysis of the same to identify any abnormal or slowly deteriorating conditions.
- 2.7** The designed array capacity at STC shall be suitably determined to meet the proposed guaranteed generation output at the point of interconnection by the contractor in his bid. The contractor shall take care of first year degradation also by installing additional DC capacity as the CUF calculations will not factor the first-year degradation of the modules.
- 2.8** Each component offered by the bidder shall be of established reliability. The minimum target reliability of each equipment shall be established by the bidder considering its mean time between failures and mean time to restore, such that the availability of complete system is assured. Bidder's recommendation of the spares shall be on the basis of established reliability.
- 2.9** Bidder shall design the plant and equipment in order to have sustained life of 25 years with minimum maintenance efforts.
- 2.10** The work execution planning for supply, erection, commissioning and all other allied works for SPV Power Plant shall be such that it is completed within stipulated time from the date of order/ LOI/ NTP, whichever is later.

B Electrical System

1 Photovoltaic Modules

1.1 Standards and Codes

Photovoltaic Modules shall comply with the specified edition of the following standards and codes.

Standard	Description
IEC 61215-1:2016 Ed.1	Terrestrial photovoltaic (PV) modules - Design qualification and type approval - Part 1: Test requirements



Bharat Coking Coal Limited

Tender for Design, Engineering, Procurement & Supply, Construction & Erection, Testing, Commissioning, Associated Transmission System and Comprehensive O&M for 5 (Five) Years of 20 MW (AC)/28 MWp (DC) Solar PV Power Plant and connecting Transmission lines at Dugdha Washery, BCCL- Dhanbad



CNUL

IEC 61215-1-1:2016/2021Ed.1	Terrestrial photovoltaic (PV) modules - Design qualification and type approval - Part 1-1: Special requirements for testing of crystalline silicon photovoltaic (PV) modules
IEC 61730-1:2016 Ed.2	Photovoltaic (PV) module safety qualification - Part 1: Requirements for construction
IEC 61730-2:2016 Ed.2	Photovoltaic (PV) module safety qualification - Part 2: Requirements for testing
IEC 61701:2011/2020 Ed.2	Salt mist corrosion testing of photovoltaic (PV) modules (Applicable for coastal and marine environment)
IEC 62716:2013 Ed.1	Photovoltaic (PV) modules - Ammonia corrosion testing (if applicable)
IEC TS 62804-1:2015 Ed.1	Photovoltaic (PV) modules - Test methods for the detection of potential-induced degradation - Part 1: Crystalline silicon (under conditions of 85°C/85% RH for minimum 192 hours)
<p>As per the Solar Photovoltaics, Systems, Devices and Components Goods (Requirements for Compulsory Registration) Order, 2017, PV Modules used in the grid connected solar power projects shall be registered with BIS and bear the Standard Mark as notified by the Bureau of Indian Standards.</p> <p>Further, PV Modules should have been included in the ALMM list as per MNRE Approved Models and Manufacturers of Solar Photovoltaic Modules (Requirements for Compulsory Registration) Order, 2019.</p>	

1.2 Technical Requirements

Parameter	Specification
Cell type	Mono-PERC (Peak Power rating of Module must not be less than 480 Wp)
Module Efficiency (Front side)	20.10 %
Open Circuit Voltage	50.80
Short Circuit Current	11.99 A
Maximum Power Point Voltage	42.00 V
Maximum Power Point Current	11.42 A
No of Cells	150
Rated power at STC	No negative tolerance is allowed
Temperature co-efficient of power	(a) Open Circuit Voltage = (-) 0.26 %/ °C (b) Short circuit current = (+) 0.04%/ °C (c) Maximum Power = (-) 0.36/ °C

20 MW (AC) Solar PV Power Plant at Dugdha, BCCL- Dhanbad, Jharkhand

Tender No.

.....

28 | Page



Bharat Coking Coal Limited

Tender for Design, Engineering, Procurement & Supply, Construction & Erection, Testing, Commissioning, Associated Transmission System and Comprehensive O&M for 5 (Five) Years of 20 MW (AC)/28 MWp (DC) Solar PV Power Plant and connecting Transmission lines at Dugdha Washery, BCCL- Dhanbad



CNUL

Application Class as per IEC 61730

Class II

1.3 Supplier Qualification Criteria

The PV Modules Supplier should have supplied minimum 500 MW in India in the past 5 years.

1.4 Component Specifications

1.4.1 The PV modules glass panel shall be:

- (i) For PV modules with backsheets, toughened low iron glass with minimum thickness of 3.2 mm for multi or mono-crystalline modules.
- (ii) In case of glass-glass modules, with minimum of 2 mm glass thickness on each side. It shall be laminated using a laminator with symmetrical structure, i.e. heating plates on both sides.
- (iii) The glass used shall have transmittance of above 90%.

1.4.2 The back sheet used in the PV modules shall be of three-layered structure durable for humid – hot conditions with properties of moisture barrier, elongation retention and UV resistance. The back sheet shall have the following properties.

Parameter	Value
Material thickness	≥ 300 micron
Water vapour transmission rate	< 2 g/m ² /day
Partial discharge test voltage	≥ 1000 V / 1500 V
Elongation at break	> 100%
Adhesion strength with encapsulant	> 40 N/cm
Interlayer adhesion strength	> 4 N/cm

The Employer reserves the right to conduct Pressure Cooker (PC) test/ Highly Accelerated Stress Test (HAST) to confirm the durability of the back sheet in accelerated conditions.

Pressure Cooker Test shall be carried out under following conditions:

121 °C /100 %RH and 2 ATM pressure for 48 hours. The apparatus shall be such that specimen is not dipped in water but exposed to vapor (steam) while maintaining aforementioned conditions. Necessary sensors for measurement of temperature, pressure and RH shall be installed for verification.

For acceptance:

- 1. There shall be no delamination or microcracks observed in the back sheet.



Bharat Coking Coal Limited

Tender for Design, Engineering, Procurement & Supply, Construction & Erection, Testing, Commissioning, Associated Transmission System and Comprehensive O&M for 5 (Five) Years of 20 MW (AC)/28 MWp (DC) Solar PV Power Plant and connecting Transmission lines at Dugdha Washery, BCCL- Dhanbad



CNUL

2. The back sheet shall retain 30% of the initial value (as per approved GTP) of the Elongation at Break.

1.4.3 The encapsulant used for the PV modules should be polyolefin based, UV resistant and PID resistant in nature. No yellowing of the encapsulant with prolonged exposures shall occur. The encapsulant shall have the following properties.

Parameter	Value
Gel content	> 75%
Transmittance	>90%
Volume resistivity	> $1 \times 10^{15} \Omega.cm$
Peeling strength with glass	> 40 N/cm

1.4.4 The sealant used for edge sealing of PV modules shall have excellent moisture ingress protection with good electrical insulation (Break down voltage >15 kV/mm) and with good adhesion strength. Edge tapes for sealing are not allowed.

1.4.5 The module frame shall be made of anodized Aluminium, which shall be electrically & chemically compatible with the structural material used for mounting the modules. It is required to have provision for earthing to connect it to the earthing grid. The anodization thickness shall not be less than 15 micron.

1.4.6 The material used for junction box shall be UV resistant to avoid degradation during module life. The degree of protection of the junction box shall be at least IP67. Minimum three number of bypass diodes and two number of IEC 62852/EN 50521 certified MC4 compatible connectors with appropriate length of IEC 62930/EN 50618 certified 4 sq.mm copper cable shall be provided. The cable length shall be in accordance with the PV Module wiring strategy and adequate to ensure that the cable bending radius standard is not exceeded.

1.4.7 Each PV Module shall be provided a RFID tag which is embedded inside the module lamination and must be able to withstand harsh environmental conditions. The RFID data base shall contain the following information. RFID scanner and database of all the modules containing the following information shall also be provided.

- (i) Name of the manufacturer of PV Module
- (ii) Name of the Manufacturer of Solar cells
- (iii) Type of cell: Mono / Multi
- (iv) Month and year of the manufacture (separately for solar cells and module)



Bharat Coking Coal Limited

Tender for Design, Engineering, Procurement & Supply, Construction & Erection, Testing, Commissioning, Associated Transmission System and Comprehensive O&M for 5 (Five) Years of 20 MW (AC)/28 MWp (DC) Solar PV Power Plant and connecting Transmission lines at Dugdha Washery, BCCL- Dhanbad



CNUL

- (v) Country of origin (separately for solar cells and module)
- (vi) I-V curve for the module
- (vii) Peak Wattage, I_m , V_m and FF for the module
- (viii) Unique Serial No. and Model No. of the module.
- (ix) Date and year of obtaining IEC PV module qualification certificate
- (x) Name of the test lab issuing IEC certificate
- (xi) Other relevant information on traceability of solar cells and modules as per ISO9000 series.

1.5 Warranty

- 1.5.1** PV modules must be warranted with linear degradation rate of power output except for first year (maximum 3% including LID) and shall guarantee 80% of the initial rated power output at the end of 25 years.
- 1.5.2** The modules shall be warranted, against all material/ manufacturing defects and workmanship for minimum of 10 years from the date of supply.
- 1.5.3** The above warranties shall be backed by third party insurance.

1.6 Approval

- 1.6.1** The Contractor shall provide Guaranteed Technical Particular (GTP) datasheet and Bill of Materials (BOM) of the module that is submitted for approval along with the datasheets of each component. The component datasheet shall contain all the information to substantiate the compliance for component specifications mentioned above.
- 1.6.2** The Contractor shall also provide test certificates corresponding to the standards mentioned above along with complete test reports for the proposed module. The tests should have been conducted at a test laboratory compliant with ISO 17025 for testing and calibration and accredited by an ILAC/IECEE member signatory. Laboratory accreditation certificate or weblink along with scope of accreditation shall also be submitted.
- 1.6.3** The BOM proposed shall be the subset of Constructional Data Form (CDF)'s of all the test reports.
- 1.6.4** The Contractor shall submit a detailed Manufacturing Quality Plan (MQP) for the PV Module with list of checks/tests performed during incoming material inspection, production, pre-dispatch and package.
- 1.6.5** The Contractor shall obtain the approval of the proposed module make & model prior to

20 MW (AC) Solar PV Power Plant at Dugdha, BCCL- Dhanbad, Jharkhand	<u>Tender No.</u> <u>.....</u>	31 Page
--	--	------------------



Bharat Coking Coal Limited

Tender for Design, Engineering, Procurement & Supply, Construction & Erection, Testing, Commissioning, Associated Transmission System and Comprehensive O&M for 5 (Five) Years of 20 MW (AC)/28 MWp (DC) Solar PV Power Plant and connecting Transmission lines at Dugdha Washery, BCCL- Dhanbad



manufacturing/ inspection call.

1.7 Manufacturing and Inspection

- 1.7.1** The Contractor shall inform the module manufacturing schedule to the Employer at least 15 (fifteen) working days before the start of proposed schedule.
- 1.7.2** Employer may arrange for inspection via Third Party Agency at the manufacturer’s factory before the start of proposed manufacturing schedule. Proof of procurement of components as per the approved BOM mentioning manufacturer name, manufacturing date and relevant test certificate shall be submitted during material inspection for verification. Payment towards Third Party Agency Inspection fee shall be borne by EPC Contractor. The Manufacturing shall start only after the clearance by the Employer after the material inspection.
- 1.7.3** The cells used for module making shall be free from all defects like edge chipping, breakages, printing defects, discoloration of top surface etc. Only Class A solar cell shall be used.
- 1.7.4** The modules shall be uniformly laminated without any lamination defects.
- 1.7.5** Current binning of modules shall be employed to limit current mismatch of modules. Different colour codes shall be provided on the modules as well as pallet for identification of different bins. Maximum three nos. of bins will be allowed for each module rating.
- 1.7.6** Pre-dispatch inspection of modules shall be performed as per the inspection protocol attached in Annexure – A: PV Module Pre-dispatch Inspection Protocol.

1.8 Transportation, Handling, Storage and Installation

- 1.8.1** Transportation, handling, storage and installation of modules shall be in accordance with the manufacturer manual so as not to breach warranty conditions. The Standard Operating Procedure (SOP) for the same shall be shared by the Contractor prior to dispatch.
- 1.8.2** It is required to construct a temporary platform (graded) while keeping the modules at least above the highest flood level. If the contractor scheduled/ planned to mount the modules immediately after the receipt at site, then the module shall be kept in common storage area with proper arrangement.
- 1.8.3** The modules shall be stacked as per the manufacturer’s recommendation only and shall be covered with tarpaulin sheet in case the PV Modules are required to be stored at site for more than one month. In any case, the temporary platform for keeping the modules shall be treated

20 MW (AC) Solar PV Power Plant at Dugdha, BCCL- Dhanbad, Jharkhand	<u>Tender No.</u> <u>.....</u>	32 Page
--	--	------------------



Bharat Coking Coal Limited

Tender for Design, Engineering, Procurement & Supply, Construction & Erection, Testing, Commissioning, Associated Transmission System and Comprehensive O&M for 5 (Five) Years of 20 MW (AC)/28 MWp (DC) Solar PV Power Plant and connecting Transmission lines at Dugdha Washery, BCCL- Dhanbad



with anti-termite treatment.

2 String Monitoring Unit

2.1 Standards and Codes

Standard/Code	Description
IEC 60529	Enclosure Ingress Protection
IEC 62262	Enclosure Impact Protection
IEC 60269	Fuse
IEC 61643-31 or EN 50539-11	Surge Protection Device
IEC 62852 or EN 50521	Solar cable connector
IEC 60695-2-11	Fire hazard testing

2.2 Construction

2.2.1 SMU enclosure shall be made of UV resistant, fire retardant, thermoplastic material. Enclosure degree of protection shall be at least IP66/67 and mechanical impact resistance shall be at least IK **IK10 with hinge and latch lock. Minimum size of Enclosure should be 850 x 700mm and internal temperature rise should be <10 Deg C on full Load (Isc) as per IEC 61439-1&2 Standard.**

2.2.2 Not more than two strings can be connected in parallel to a single input of SMU. Onespere input terminal along with connector shall be provided for each SMU.

2.2.3 Every SMU input shall be provided with fuses on both positive and negative side. In case of negative grounded system, fuse at positive side only is acceptable. The rating of the fuses shall be selected such that it protects the modules from reverse current overload. The fuses shall be ‘gPV’ type conforming to IEC 60269-6.

2.2.4 DC switch disconnecter of suitable rating shall be provided at SMU output to disconnect both positive and negative side simultaneously.

2.2.5 Type-II surge protective device (SPD) conforming to IEC 61643-31 / EN 50539-11 shall be connected between positive/negative bus and earth.

2.2.6 Resistance Temperature Detector (RTD) type or semiconductor type temperature sensor shall be provided to monitor the cabinet temperature.

2.2.7 MC4 connector conforming to IEC 62852 or EN 50521 shall be provided at each SMU input. Cable gland (double compression metallic) of suitable size for DC cables shall be provided at



Bharat Coking Coal Limited

Tender for Design, Engineering, Procurement & Supply, Construction & Erection, Testing, Commissioning, Associated Transmission System and Comprehensive O&M for 5 (Five) Years of 20 MW (AC)/28 MWp (DC) Solar PV Power Plant and connecting Transmission lines at Dugdha Washery, BCCL- Dhanbad



CNUL

the SMU output.

- 2.2.8** UV resistant printed cable ferrules for solar cables & communication cables and punched/ embossed aluminium tags for DC cables shall be provided at cable termination points for identification.
- 2.2.9** Suitable communication interface shall be provided to communicate the data to SCADA. The following parameters shall be measured/ monitored and made available at SCADA.
 - (i) String current
 - (ii) Bus voltage
 - (iii) Output current
 - (iv) Cabinet temperature
 - (v) DC disconnect switch ON/OFF status
 - (vi) SPD operating status
- 2.2.10** Galvanic Isolation to be maintained between power board and communication board of Monitoring device for ease of Maintenance using shunt measurement technology .
- 2.2.11** Communication of SMU with SCADA should be Wireless, preferably AES 128 bit Encryption, Spread spectrum Technology, Wireless Communication should have following features for hassle free communication with refresh rate <10 sec per SMU.
 - a) Carrier Sense
 - b) Collision Detect
 - c) Collision Avoidance

2.3 Warranty

The SMU unit shall be warranted against all material/manufacturing defects and workmanship for minimum of 2 (two) years from the date of supply.

2.4 Tests

Routine tests and acceptance tests for the assembled unit shall be as per the Quality Assurance Plan (QAP) approved by the Employer.

3 **Solar and DC Cables**

3.1 Standards and Codes

Cable	From	To	Conductor/ Insulation	Voltage Rating	Applicable Standard
-------	------	----	--------------------------	-------------------	------------------------



Bharat Coking Coal Limited

Tender for Design, Engineering, Procurement & Supply, Construction & Erection, Testing, Commissioning, Associated Transmission System and Comprehensive O&M for 5 (Five) Years of 20 MW (AC)/28 MWp (DC) Solar PV Power Plant and connecting Transmission lines at Dugdha Washery, BCCL- Dhanbad



Solar Cable*	Module	SMU	Copper/ XLPO	1.1 kV DC/ 1.5 kV DC	IEC 62930/ EN 50618/
DC Cable	SMU	PCU	Copper or Aluminium/ XLPE	1.1 kV DC/ 1.5 kV DC	IS 7098
* Cable used for module interconnection shall also be referred as solar cable.					

- 3.2** Solar cable outer sheath shall be flame retardant, UV resistant and black in colour. Solar cable with positive polarity should have marking of red line on black outer sheath.
- 3.3** DC cables shall be single core, armoured, Flame Retardant Low smoke (FRLS), PVC outer sheath conforming to IS 7098. DC cable with positive polarity should have marking of red line on black outer sheath.
- 3.4** In addition to manufacturer's identification on cables as per relevant standard, following marking shall also be provided over outer sheath.
- (i) Cable size and voltage grade
 - (ii) Word 'FRNC/ FRLS' (as applicable) at every metre
 - (iii) Sequential marking of length of the cable in metres at every metre
- 3.5** Cables shall be sized based on the following considerations: (i) Rated current of module
- (ii) Total power loss in the cables (Modules to Inverter) shall be limited to 1.5 %. The Contractor shall provide power loss calculations in excel sheet.
 - (iii) Short circuit withstand capability
 - (iv) De-rating factors according to laying pattern
- 3.6** Warranty
The cables (Solar and DC) shall be warranted against all material/ manufacturing defects and workmanship for minimum of 1 (one) year from the date of supply.
- 3.7** Tests
Type test, routine test and acceptance tests requirements shall be as per IEC 62930/EN 50618 for solar cables and IS 7098 for DC cables.
- 3.8** Installation
- 3.8.1** Cable installation shall be as per IS 1255.
- 3.8.2** Only terminal cable joints shall be accepted. No cable joint to join two cable ends shall be



Bharat Coking Coal Limited

Tender for Design, Engineering, Procurement & Supply, Construction & Erection, Testing, Commissioning, Associated Transmission System and Comprehensive O&M for 5 (Five) Years of 20 MW (AC)/28 MWp (DC) Solar PV Power Plant and connecting Transmission lines at Dugdha Washery, BCCL- Dhanbad



accepted.

- 3.8.3** Solar cables shall be provided with UV resistant printed ferrules and DC cables shall be provided with punched/ embossed aluminium tags. The marking shall be done with good quality letter and numbers of proper size so that the cables can be identified easily.
- 3.8.4** Cable terminations shall be made with properly crimped lugs and passed through cable glands at the entry & exit point of the cubicles. Bimetallic lugs shall be used for connecting Cu bus bar and Al cables or vice-versa.
- 3.8.5** Solar cables, wherever exposed to direct sunlight and buried underground, shall be laid through Double Wall Corrugated (DWC) HDPE conduits. The size of the conduit pipe shall be selected on the basis of 40% fill criteria.
- 3.8.6** Solar cables shall be aesthetically tied to Module Mounting Structure using UV resistant cable-ties suitable for outdoor application.
- 3.8.7** A.C and D.C cables shall be kept in separate trenches. The horizontal and vertical clearances between power and communication cable shall not be less than 300mm.

3.8.8 Cable Sealing System

Modular multi-diameter cable sealing system consisting of frames, blocks and accessories shall be installed where the underground and over ground cables enter or leave LCR/MCR/BESS enclosures. Cable sealing system shall consist of multi-diameter type peelable blocks of different sizes to suit the various cables. It should be simple, easy and quick to assemble & re-assemble the cable sealing system. Solid blocks shall not be used on frame. Frames & stay-plate material shall be of galvanized steel and for compression, single piece wedge with galvanized steel bolts shall be used. 30% spare blocks on the frame shall be provided for expansion in future. Cable sealing system should have been tested for fire/ water /smoke tightness.

4 Power Conditioning Unit

4.1 Standards and Codes

Power Conditioning Unit (PCU) shall comply with the specified edition of the following standards and codes.

Standard	Description
IEC 61683 Ed. 1	Photovoltaic systems - Power conditioners - Procedure for measuring efficiency



Bharat Coking Coal Limited

Tender for Design, Engineering, Procurement & Supply, Construction & Erection, Testing, Commissioning, Associated Transmission System and Comprehensive O&M for 5 (Five) Years of 20 MW (AC)/28 MWp (DC) Solar PV Power Plant and connecting Transmission lines at Dugdha Washery, BCCL- Dhanbad



IEC 62109-1 Ed. 1	Safety of power converters for use in photovoltaic power systems - Part 1: General requirements
IEC 62109-2 Ed. 1	Safety of power converters for use in photovoltaic power systems - Part 2: Particular requirements for inverters
IEC 61000-6-2 Ed. 2	Electromagnetic compatibility (EMC) - Part 6-2: Generic standards - Immunity standard for industrial environments
IEC 61000-6-4 Ed. 2.1	Electromagnetic compatibility (EMC) - Part 6-4: Generic standards - Emission standard for industrial environments
IEC 62116 Ed. 2	Utility-interconnected photovoltaic inverters - Test procedure of islanding prevention measures
IEC 60068-2-1:2007	Environmental testing - Part 2-1: Tests - Test A: Cold
IEC 60068-2-2:2007	Environmental testing - Part 2-2: Tests - Test B: Dry heat
IEC 60068-2-14:2009	Environmental testing - Part 2-14: Tests - Test N: Changeof temperature
IEC 60068-2-30:2005	Environmental testing - Part 2-30: Tests - Test Db: Dampheat, cyclic (12 h + 12 h cycle)
CEA Technical Standards for Connectivity to the Grid Regulations 2007 with 2013 and 2019 Amendment	
As per the Solar Photovoltaics, Systems, Devices and Components Goods (Requirements for Compulsory Registration) Order, 2017, Inverters used in the grid connected solar power projects shall be registered with BIS and bear the Standard Mark as notified by the Bureau of Indian Standards.	

4.2 Supplier Qualification Criteria

The Inverter Supplier should have supplied minimum 1 GW in India in the past 5 years. The solar inverter supplier shall be Class-I local supplier as per MNRE Order dated 23rd Sep, 2020 on Public Procurement (Preference to Make in India) to provide for Purchase Preference (linked with local content) in respect of Renewable Energy (RE) Sector.

4.3 Technical Requirements

Parameter	Specification
Rated AC power	As per design

20 MW (AC) Solar PV Power Plant at Dugdha, BCCL- Dhanbad, Jharkhand

Tender No.
.....



Bharat Coking Coal Limited

Tender for Design, Engineering, Procurement & Supply, Construction & Erection, Testing, Commissioning, Associated Transmission System and Comprehensive O&M for 5 (Five) Years of 20 MW (AC)/28 MWp (DC) Solar PV Power Plant and connecting Transmission lines at Dugdha Washery, BCCL- Dhanbad



CNUL

Maximum input voltage	1500 V
Rated AC output voltage	As per design
Tolerance on rated AC output voltage	+/-10%
Rated frequency	50 Hz
Operating frequency range	47.5 Hz to 52 Hz
Power factor control range	0.9 lag to 0.9 lead
European efficiency	Minimum 98%
Maximum loss in Sleep Mode	0.05% of rated AC power
Total Harmonic Distortion	Less than 3% at 100% load
Degree of protection	Central Inverter – IP 20 (Indoor)/IP 54 (Outdoor), String Inverter – IP 65

- 4.3.1** The rated/ name plate AC capacity of the PCU shall be AC power output of the PCU at 50°C.
- 4.3.2** Maximum power point tracker (MPPT) shall be integrated in the PCU to maximize energy drawn from the Solar PV array. The MPPT voltage window shall be sufficient enough to accommodate the output voltage of the PV array at extreme temperatures prevailing at site.
- 4.3.3** The PCU output shall always follow the grid in terms of voltage and frequency. The operating voltage and frequency range of the PCU shall be sufficient enough to accommodate the allowable grid voltage and frequency variations.

4.4 Construction

- 4.4.1** Power Conditioning Unit (PCU) shall consist of an electronic three phase inverter along with associated control, protection, filtering, measurement and data logging devices.
- 4.4.2** Every DC input terminal of PCU shall be provided with fuse/MCB/MCCB of appropriate rating. One spare DC input terminal shall be provided for each PCU.
- 4.4.3** Type-II surge protective device (SPD) conforming to IEC 61643-31 / EN 50539-11 shall be connected between positive/ negative bus and earth.
- 4.4.4** In case external auxiliary power supply is required, UPS shall be used to meet auxiliary power requirement of PCU. It shall have a backup storage capacity of 2 hours.
- 4.4.5** Circuit Breaker of appropriate voltage and current rating shall be provided at the output to isolate the PCU from grid in case of faults.
- 4.4.6** The PCU shall be tropicalized and the design shall be compatible with conditions prevailing



Bharat Coking Coal Limited

Tender for Design, Engineering, Procurement & Supply, Construction & Erection, Testing, Commissioning, Associated Transmission System and Comprehensive O&M for 5 (Five) Years of 20 MW (AC)/28 MWp (DC) Solar PV Power Plant and connecting Transmission lines at Dugdha Washery, BCCL- Dhanbad



at site. Suitable number of exhaust fan with proper ducting shall be provided for cooling keeping in mind the extreme climatic condition of the site as per the recommendations of OEM to achieve desired performance and life expectancy.

4.4.7 All the conducting parts of the PCU that are not intended to carry current shall be bonded together and connected to dedicated earth pits through protective conductor of appropriate size. DC negative terminal shall be grounded. In case DC negative grounding is not possible, appropriate anti-PID device shall be provided.

4.4.8 Dedicated communication interface shall be provided to monitor the PCU from SCADA.

4.4.9 PCU front panel shall be provided with LCD/ LED to display all the relevant parameters related to PCU operation and fault conditions. It shall include, but not limited to, the following parameters.

- (i) DC input power
- (ii) DC input voltage
- (iii) DC input current (for each terminal)
- (iv) AC output power
- (v) AC output voltage (all the 3 phases and line)
- (vi) AC output current (all the 3 phases and line)
- (vii) Frequency
- (viii) Power Factor

In case of outdoor PCU, PCU without LCD display with provision for data access over Bluetooth shall be acceptable.

4.5 Operating Modes

Operating modes of PCU shall include, but not limited to, the following modes. These operating modes and conditions for transition are indicative only. The Contractor shall provide the detailed flow chart indicating the various operating modes and conditions for transition during detailed engineering.

4.5.1 Standby Mode

The PCU shall continuously monitor the input DC voltage and remain on Standby Mode until it reaches the pre-set value.

4.5.2 MPPT Mode



Bharat Coking Coal Limited

Tender for Design, Engineering, Procurement & Supply, Construction & Erection, Testing, Commissioning, Associated Transmission System and Comprehensive O&M for 5 (Five) Years of 20 MW (AC)/28 MWp (DC) Solar PV Power Plant and connecting Transmission lines at Dugdha Washery, BCCL- Dhanbad



When the input DC voltage is above the pre-set value and AC grid connection conditions are fulfilled, the PCU shall enter into MPPT mode.

4.5.3 Sleep Mode

When the AC output power/DC input voltage decreases below the pre-set value for pre-set time delay, the PCU shall switch into Sleep Mode.

4.6 Protection Features

The PCU shall include appropriate self-protective and self-diagnostic feature to protect itself and the PV array from damage in the event of PCU component failure or from parameters beyond the PCU’s safe operating range due to internal or external causes. The self-protective features shall not allow signals from the PCU front panel to cause the PCU to be operated in a manner which may be unsafe or damaging. Faults due to malfunctioning within the PCU, including commutation failure, shall be cleared by the PCU protective devices.

The PCU shall provide protection against the following type of faults, among others.

- (i) DC/AC over current
- (ii) DC/AC over voltage
- (iii) DC reverse polarity
- (iv) DC earth fault
- (v) AC under voltage
- (vi) AC under frequency/over frequency
- (vii) Islanding
- (viii) Over temperature
- (ix) Lightning surges

4.7 Grid Support Functions

4.7.1 Active power regulation

The PCU shall be able to limit the active power exported to the grid based on the setpoint provided through PCU front control panel. The PCU shall also be able to automatically limit the active power after an increase in grid frequency above a pre-set value. The ramp rate shall be adjustable during operation and start-up after fault. The applicability of the requirement shall be as per CEA regulation and compliance.



Bharat Coking Coal Limited

Tender for Design, Engineering, Procurement & Supply, Construction & Erection, Testing, Commissioning, Associated Transmission System and Comprehensive O&M for 5 (Five) Years of 20 MW (AC)/28 MWp (DC) Solar PV Power Plant and connecting Transmission lines at Dugdha Washery, BCCL- Dhanbad



CNUL

4.7.2 Reactive power control

The PCU shall be able to inject /absorb reactive power to/ from the grid based on the set point provided through PCU front control panel. The same shall be performed automatically with adjustable ramp rate based on dynamic changes in grid voltage or reactive power reference.

4.7.3 Voltage Ride Through

The PCU shall remain connected to the grid during temporary dip or rise in grid voltage as per the LVRT and HVRT requirements of CEA Technical Standards for Connectivity to the Grid Regulations. The PCU shall also be able to inject reactive power during the period of voltage dip.

4.8 Warranty

The complete Power Conditioning Unit shall be warranted against all material/ manufacturing defects and workmanship for a minimum of 5 (five) years from the date of supply.

4.9 Tests

4.9.1 Type Tests

The type test certificates as per the standards mentioned above should be from any of the ILAC/IECEE member signatory accredited Test Centres. Laboratory accreditation certificate or weblink along with scope of accreditation shall also be submitted. It is the responsibility of the Contractor to substantiate the compliance for CEA Regulations using test reports.

4.9.2 Routine Tests

Routine tests and acceptance tests shall be as per the Quality Assurance Plan (QAP) approved by the Employer.



Bharat Coking Coal Limited

Tender for Design, Engineering, Procurement & Supply, Construction & Erection, Testing, Commissioning, Associated Transmission System and Comprehensive O&M for 5 (Five) Years of 20 MW (AC)/28 MWp (DC) Solar PV Power Plant and connecting Transmission lines at Dugdha Washery, BCCL- Dhanbad



CNUL

5 Inverter Transformer and Auxiliary Transformer

5.1 Standards and Codes

Inverter transformer and auxiliary transformer, wherever applicable, shall comply with the latest edition of the following standards and codes including amendments.

Standard	Description
IS 2026, IEC 60076	Specification of Power Transformers
IS 11171, IEC 60076	Dry-Type Power Transformers
IS 2099, IEC 60137	Bushings for alternate voltage above 1000 V
IS 335, IEC 60296	Insulating oil
IS 3639	Fittings and Accessories for Power Transformers
IS 12063	Degree of protection provided by enclosures
CBIP publication no. 295	
Indian Electricity rules and other statutory regulations	

5.2 Technical Requirements

Parameters	Inverter Transformer	Auxiliary Transformer
VA Rating	As per system design requirement	



Bharat Coking Coal Limited

Tender for Design, Engineering, Procurement & Supply, Construction & Erection, Testing, Commissioning, Associated Transmission System and Comprehensive O&M for 5 (Five) Years of 20 MW (AC)/28 MWp (DC) Solar PV Power Plant and connecting Transmission lines at Dugdha Washery, BCCL- Dhanbad



Voltage Ratio	33 kV / Inverter output voltage	As per system design
Duty, Service & Application	Continuous Solar Inverter application and converter Duty (Outdoor)	Continuous application (Outdoor/Indoor)
Winding	As per system design requirement	2
Frequency	50 Hz	50Hz
Nos. of Phase	3	3
Vector Group & Neutral earthing	As per system/inverter manufacturer requirement	Dyn11
Cooling	ONAN	ONAN/ AN
Tap Changer	OCTC, No. of steps shall be as per system requirement	
Impedance at 75°C	As per Inverter Manufacturer requirement	As per system requirement
Permissible Temperature rise over an ambient of 50°C (irrespective of tap)		
Top Oil	50°C	As per IS/IEC
Winding	55°C	As per IS/IEC
SC withstand time (thermal)	2 second	2 second
Short Circuit Apparent power	As per system requirement	
Termination	As per system requirement	
Bushing rating, Insulation class (Winding & bushing)	36 kV – porcelain bushings 1.1 kV – epoxy bushings	As per the system requirement
Noise level	As per NEMA TR-1	
Loading Capability	Continuous operation at rated MVA on any tap with voltage variation of +/-3%, also transformer shall be capable of being loaded in accordance with IEC 60076-7	

20 MW (AC) Solar PV Power Plant at Dugdha, BCCL- Dhanbad, Jharkhand

Tender No.
.....

43 | Page



Bharat Coking Coal Limited

Tender for Design, Engineering, Procurement & Supply, Construction & Erection, Testing, Commissioning, Associated Transmission System and Comprehensive O&M for 5 (Five) Years of 20 MW (AC)/28 MWp (DC) Solar PV Power Plant and connecting Transmission lines at Dugdha Washery, BCCL- Dhanbad



Flux density	Not to exceed 1.9 Wb/sq.m. at any tap position with combined frequency and voltage variation from rated V/fratio by 10% corresponding to the tap. Transformer shallalso withstand following over fluxing conditions due to combined voltage and frequency fluctuations: a) 110% for continuous rating b) 125% for at least one minute c) 140% for at least five seconds. Bidder shall furnish over fluxing characteristic up to 150%
Air Clearance	As per CBIP

5.3 Construction

- 5.3.1** The transformer shall be provided with conventional single compartment conservatorwith prismatic toughened glass oil gauge. The top of the conservator shall be connected to the atmosphere through indicating type cobalt free silica gel breather with transparent enclosure. Silica gel shall be isolated from atmosphere by an oil seal. Inverter transformers shall be provided with Magnetic Oil Gauge (MOG) with low oil level alarm contact.
- 5.3.2** It is the responsibility of the Contractor to ensure that the inverter transformer complywith all the requirements of inverter provided by the inverter manufacturer.
- 5.3.3** Inverter Transformer shall be designed for at least 5% total harmonic distortion (THD)to withstand distortion generated by the inverter as well as possible outside harmonics from the network.
- 5.3.4** The transformer shall be suitable for continuous operation with a frequency variationof ± 2.5% from nominal frequency of 50 Hz without exceeding the specified temperature rise.
- 5.3.5** Inverter Transformer shall have shield winding between LV & HV windings. Each LV winding must be capable of handling non-sinusoidal voltage with voltage gradient asspecified by the inverter manufacturer. Also, shield winding shall be taken out from tank through shield bushing and the same shall be brought down to the bottom of thetank using copper flat and support insulator for independent grounding.
- 5.3.6** Neutral bushing of Inverter duty transformer shall be brought outside the tank for thetesting purpose. It shall be covered with MS sheet and a sticker “For testing purposeonly. Do not earth”. Neutral bushing of auxiliary transformer shall be brought outsidethe tank for earthing.
- 5.3.7** Inverter transformer shall have 150 mm dial type Oil Temperature Indicator (OTI) andWinding Temperature Indicator (WTI) with alarm and trip contacts. All indicators shallhave accuracy



Bharat Coking Coal Limited

Tender for Design, Engineering, Procurement & Supply, Construction & Erection, Testing, Commissioning, Associated Transmission System and Comprehensive O&M for 5 (Five) Years of 20 MW (AC)/28 MWp (DC) Solar PV Power Plant and connecting Transmission lines at Dugdha Washery, BCCL- Dhanbad



CNUL

of 1.5%. For inverter transformers, WTI shall be provided for all the windings.

- 5.3.8** The radiators shall be detachable type, mounted on the tank with shut off valve at each point of connection to the tank, lifts, along with drain plug/ valve at the bottom and air release plug at the top.
- 5.3.9** Marshalling Box shall be of sheet steel, dust and vermin proof provided with proper lighting and thermostatically controlled space heaters. The degree of protection shall be IP 55. Marshalling Box of all transformers shall be preferably Tank Mounted. Onedummy terminal block in between each trip wire terminal shall be provided. At least 10% spare terminals shall be provided on each panel. The gasket used shall be of neoprene rubber. Wiring scheme (TB details) shall be engraved in a stainless-steel plate with viewable font size and the same shall be fixed inside the Marshalling Box door.
- 5.3.10** Buchholz relay, double float type with alarm and trip contacts, along with suitable gas collecting arrangement shall be provided.
- 5.3.11** Inverter transformer shall be provided with spring operated Pressure Relief Device (with trip contacts) with suitable discharge arrangement for oil. For Auxiliary transformers, diaphragm type explosion vent shall be provided.
- 5.3.12** Filter valve at top the tank and drain cum sampling valve at bottom of the tank shall be provided.
- 5.3.13** All external surface of the transformer shall be painted with two coats of epoxy-basedpaint of colour shade RAL 7032. Internal surface of cable boxes and marshalling boxshall be painted with epoxy enamel white paint. The minimum dry film thickness (DFT) shall be 100 microns.
- 5.3.14** LV and HV cable box shall be provided with disconnecting chamber to facilitate the movement of transformer without disturbing cable box and termination.
- 5.3.15** Air release plug, bi-directional wheel/skids, cover lifting eyes, transformer lifting lugs,jacking pads, towing holes, core and winding lifting lugs, inspection cover, rating plate, valve schedule plate, accessories and terminal marking plates, two nos. of earthing terminals shall be provided.
- 5.3.16** Rain hoods to be provided on Buchholz, MOG & PRD. Entry points of wires shall besuitably sealed.
- 5.3.17** The accessories listed above are indicative only. Accessories which are not mentioned above but required for satisfactory operation of the transformers are deemed to be included in the



Bharat Coking Coal Limited

Tender for Design, Engineering, Procurement & Supply, Construction & Erection, Testing, Commissioning, Associated Transmission System and Comprehensive O&M for 5 (Five) Years of 20 MW (AC)/28 MWp (DC) Solar PV Power Plant and connecting Transmission lines at Dugdha Washery, BCCL- Dhanbad



contract without extra charges.

5.3.18 Fire-protection for inverter transformer shall be provided in accordance with relevant CEA regulations as amended time to time.

5.4 Dry Type Auxiliary Transformer

5.4.1 Transformer shall be cast resin encapsulated dry type transformer, made of cold rolled grain-oriented silicon steel laminations of M4 grade or better. Winding conductor shall be electrolytic grade Copper/Aluminium and insulation shall be Class F or better.

5.4.2 The transformers shall be housed in a metal protective housing, having a degree of protection of IP-23 suitable for indoor installation. The enclosure shall be provided with suitable hardware and accessories required for satisfactory operation of the transformer per the relevant standard.

5.5 Warranty

The transformer shall be warranted for minimum of 5 (five) years against all material/manufacturing defects and workmanship.

5.6 Testing and Inspection

5.6.1 Type Tests and Special Tests

The following type test and special test reports shall be submitted during detailed engineering. The tests should have been conducted on a similar transformer by NABL accredited laboratory.

5.6.1.1 Type Tests

(i) Lightning impulse (Full & Chopped Wave) test on windings as per IEC 60076-3 / IS 2026-3

Temperature Rise test at a tap corresponding to maximum losses as per IEC 60076-2 / IS 2026-2

5.6.1.2 Special Tests

(i) Measurement of zero-sequence impedance as per IEC 60076-1 / IS 2026-1

(ii) Measurement of harmonics of no-load current as per IEC 60076-1 / IS 2026-1

(iii) Measurement of acoustic noise level as per NEMA TR-1

(iv) Short-circuit withstand test as per IEC 60076-5 / IS 2026-5

In case the contractor is not able to submit the test reports during detailed engineering, the contractor shall submit the reports of type/special tests either conducted by NABL accredited



Bharat Coking Coal Limited

Tender for Design, Engineering, Procurement & Supply, Construction & Erection, Testing, Commissioning, Associated Transmission System and Comprehensive O&M for 5 (Five) Years of 20 MW (AC)/28 MWp (DC) Solar PV Power Plant and connecting Transmission lines at Dugdha Washery, BCCL- Dhanbad



laboratory or witnessed by Employer.

5.6.1.3 Type and Special tests are not required for auxiliary transformers of rating including 100 kVA and below. However, auxiliary transformer shall have minimum 3-star BEE rating as per BIS guidelines.

5.6.2 Routine Tests

Each completed transformer shall be subjected to following routine tests as per the latest edition of IEC 60076 / IS 2026 unless specified otherwise.

- (i) Measurement of winding resistance at each tap
- (ii) Measurement of voltage ratio between HV and LV windings at each tap
- (iii) Check of vector group
- (iv) Measurement of no-load loss and no-load current
- (v) Measurement of short-circuit impedance and load loss
- (vi) Magnetic balance test as per CBIP manual publication no. 295
- (vii) Separate source voltage withstand test
- (viii) Induced over voltage withstand test
- (ix) Measurement of insulation resistance
- (x) Marshalling box functional test
- (xi) IR Measurement on wiring of marshalling box
- (xii) Breakdown voltage test on transformer oil as per IS 335
- (xiii) Oil leakage test on completely assembled transformer along with radiators

5.6.3 Tests at Site

After erection at site all transformer(s) shall be subjected to the following tests.

- (i) Measurement of voltage ratio
- (ii) Check of vector group
- (iii) Magnetic balance test
- (iv) Measurement of insulation resistance
- (v) Breakdown voltage test on transformer oil

In case the equipment is not found as per the requirements of the Technical Specifications of NIT, all expenses incurred during site testing will be to the Contractor's account and the equipment shall be replaced by him at free of cost.

20 MW (AC) Solar PV Power Plant at Dugdha, BCCL- Dhanbad, Jharkhand	<u>Tender No.</u> <u>.....</u>	47 Page
--	--	------------------



Bharat Coking Coal Limited

Tender for Design, Engineering, Procurement & Supply, Construction & Erection, Testing, Commissioning, Associated Transmission System and Comprehensive O&M for 5 (Five) Years of 20 MW (AC)/28 MWp (DC) Solar PV Power Plant and connecting Transmission lines at Dugdha Washery, BCCL- Dhanbad



CNUL

6 HT Switchgear

6.1 Standards and Codes

All equipment provided under HT switchgear shall comply with latest editions and amendments of the relevant IEC standards and IS codes. In particular, the switchgear shall comply with the following standards and codes.

Standard/Code	Description
IS/IEC 62271-1	High Voltage Switchgear and Control gear - Part 1: Common Specifications
IS/IEC 62271-100	High Voltage Switchgear and Control gear - Part 100: AC Circuit Breakers
IS/IEC 62271-102	High Voltage Switchgear and Control gear - Part 102: AC Disconnectors and Earthing Switches
IS/IEC 62271-200	High Voltage Switchgear and Control gear - Part 200: AC Metal Enclosed Switchgear and Control gear for Rated Voltages Above 1 kV and Up to and Including 52 kV
IEC 61869	Instrument Transformers
IS 3231	Electrical relays for power systems protection
IEC 60255	Measuring relays and protection equipment
IEC 61850	Communication networks and systems for power utility automation
IEC 61131-3	Programmable controllers - Part 3: Programming languages
IS 9385	High voltage fuses
IS 9431	Indoor post insulators of organic material for systems with nominal voltages greater than 1000 V up to and including 300 kV
IEC 60099-4	Surge arresters - Part 4: Metal-oxide surge arresters without gaps for A.C. systems
IS 3070-3	Lightning Arresters for Alternating Current Systems - Part 3: Metal Oxide Lightning Arresters Without Gaps
IEC 62052-11	Electricity metering equipment (A.C.) - General requirements, tests and test conditions - Part 11: Metering equipment
IEC 62053	Electricity metering equipment (A.C.) - Particular requirements

20 MW (AC) Solar PV Power Plant at Dugdha, BCCL- Dhanbad, Jharkhand

Tender No.
.....



Bharat Coking Coal Limited

Tender for Design, Engineering, Procurement & Supply, Construction & Erection, Testing, Commissioning, Associated Transmission System and Comprehensive O&M for 5 (Five) Years of 20 MW (AC)/28 MWp (DC) Solar PV Power Plant and connecting Transmission lines at Dugdha Washery, BCCL- Dhanbad



IS 14697	AC Static Transformer Operated Watthour and Var-hour Meters, Class 0.2S and 0.5S
----------	--

6.2 Technical Parameters

Parameter	Specification
System Parameters	
Highest system voltage	36 kV
Rated system voltage	33 kV
Rated frequency	50 Hz
Number of phases	3
Power frequency withstand voltage	70 kV (r.m.s.)
Lightning impulse withstand voltage	170 kV (peak)
System fault current	As per system requirement
Circuit Breaker	
Type	Vacuum type
Operating duty cycle	O – 0.3sec – CO – 3min – CO
Short circuit breaking current	As per system requirement
Short circuit making current	2.5 times S.C. breaking current
Re-strike performance class	C2
Mechanical endurance class	M1
Current Transformer	
Accuracy class	0.2 for metering (0.2s for metering at outgoing feeder), 5P20 for protection
Rated VA burden	As per requirement
Insulation class	Class F
Voltage Transformer	
Accuracy class	0.2 for metering, 3P for protection
Rated VA burden	As per requirement
Insulation class	Class F

6.3 Switchgear Panel

20 MW (AC) Solar PV Power Plant at Dugdha, BCCL- Dhanbad, Jharkhand	<u>Tender No.</u> <u>.....</u>	49 Page
--	--	------------------



Bharat Coking Coal Limited

Tender for Design, Engineering, Procurement & Supply, Construction & Erection, Testing, Commissioning, Associated Transmission System and Comprehensive O&M for 5 (Five) Years of 20 MW (AC)/28 MWp (DC) Solar PV Power Plant and connecting Transmission lines at Dugdha Washery, BCCL- Dhanbad



CNUL

- 6.3.1** The switchgear panel shall be free standing, floor mounted, single front, single tier fully compartmentalized, metal enclosed construction. Each panel shall have separate compartments for circuit breaker, bus bars, cable termination and auxiliary circuit.
- 6.3.2** The circuit breakers shall be mounted on horizontally withdrawable trucks with locking facility in SERVICE and TEST positions.
- 6.3.3** The panel enclosure shall be constructed with CRCA steel/Aluzinc sheet. The thickness of load bearing members shall be minimum 3 mm and that of non-load bearing members shall be minimum 2 mm.
- 6.3.4** All surfaces shall be painted with two coats of epoxy-based paint of colour shade RAL 7032. The minimum dry film thickness (DFT) shall be 100 microns.
- 6.3.5** The circuit breaker and auxiliary circuit compartments provided on the front side shall have separate concealed hinged doors. Cable and bus bar compartments provided on the rear side shall have separate bolted covers. All doors and covers shall be provided with neoprene/synthetic rubber gaskets to prevent entry of vermin and dust.
- 6.3.6** Pressure relief device shall be provided in each high voltage compartment of a panel to safely vent the gases in the event of internal arc. Seal-off bushing arrangement shall be provided between the breaker compartment and bus bar/cable compartments to prevent transfer of arc from one compartment to other.
- 6.3.7** Automatic safety shutters shall be provided to cover up the fixed high voltage contacts on bus bar and cable sides when the truck is moved to TEST position.
- 6.3.8** Degree of protection shall not be less than IP 5X for auxiliary circuit compartment. However, for remaining compartments it shall not be less than IP 4X. For outdoor panels, degree of protection shall not be less than IP 55.
- 6.3.9** Mechanical /Electrical interlocks shall be provided to prevent mal-operation and in particular to ensure the following.
 - (i)** The breaker shall be operated only if it is in SERVICE or TEST position.
 - (ii)** Movement of the breaker truck between SERVICE and TEST positions shall be possible only if the breaker is OFF.
 - (iii)** It shall be possible to open the door only when the breaker is in TEST position.
- 6.3.10** Panel shall be provided with local bus-bar protection.
- 6.3.11** Each switchgear panel shall be provided with thermostatically controlled space heaters,



Tender for Design, Engineering, Procurement & Supply, Construction & Erection, Testing, Commissioning, Associated Transmission System and Comprehensive O&M for 5 (Five) Years of 20 MW (AC)/28 MWp (DC) Solar PV Power Plant and connecting Transmission lines at Dugdha Washery, BCCL- Dhanbad



separately for breaker, cable and bus bar compartments, to prevent condensation within the compartment. The space heater shall be connected to 240 V, 50 Hz, single phase AC supply through suitable switch and fuse.

- 6.3.12** 240 V, 5 A, SPN industrial socket-outlet with ON/OFF switch shall be provided in each panel.
- 6.3.13** Each panel shall be provided with LED lamp rated for 240 V, 50 Hz, single phase AC supply for interior illumination controlled by door switch.
- 6.3.14** Gapless, metal-oxide surge arrestors shall be provided between line and earth in cable compartment of the switchgear panel.
- 6.3.15** Suitable lifting hooks shall be provided for each panel.

6.4 Circuit Breakers

- 6.4.1** Circuit breakers shall be of vacuum type. It shall comprise of three separate identical single pole units operated through the common shaft and shall be fully interchangeable both electrically and mechanically.
- 6.4.2** The circuit breaker operating mechanism shall be based on motor operated spring charging and it shall be re-strike free, trip free both electrically and mechanically, with anti-pumping feature.
- 6.4.3** The rated control voltage of the spring charging motor shall be 110 VDC/230 VAC. Closing coil shall operate at all values of voltages between 85% and 110% of rated voltage. Opening coil shall operate correctly under all operating conditions of the circuit breaker up to the rated breaking capacity and at all values of supply voltage between 70% and 110% of rated voltage.
- 6.4.4** The spring charging motor shall have adequate thermal rating such that continuous sequence of the closing and opening operations is possible as long as power supply is available to the motor. It shall also be possible to charge the spring manually and close the breaker in the event of failure of motor / control supply to motor. Operating handle shall be provided for charging the operating mechanism. After failure of control supply to the motor, one open-close-open operation shall be possible with the energy contained in the operating mechanism.
- 6.4.5** The motor rating shall be such that it requires not more than 30 seconds for full charging of the closing spring. Closing action of the circuit breaker shall compress the opening spring ready for tripping. When closing springs are discharged after closing the breaker, they shall be automatically charged for the next operation.
- 6.4.6** Mechanical indicators shall be provided to indicate OPEN/CLOSED positions of the circuit

20 MW (AC) Solar PV Power Plant at Dugdha, BCCL- Dhanbad, Jharkhand	<u>Tender No.</u>	51 Page
--	-----------------------------------	------------------



Bharat Coking Coal Limited

Tender for Design, Engineering, Procurement & Supply, Construction & Erection, Testing, Commissioning, Associated Transmission System and Comprehensive O&M for 5 (Five) Years of 20 MW (AC)/28 MWp (DC) Solar PV Power Plant and connecting Transmission lines at Dugdha Washery, BCCL- Dhanbad



CNUL

breaker and CHARGED/ DISCHARGED positions of the closing spring. An operation counter shall also be provided. These indicators and counter shall be visible from the panel front door without opening it.

6.5 Relays

6.5.1 All relays shall be microprocessor based numerical type. However, auxiliary relays can be static or electromechanical type. The relays shall be flush mounted on panel front with connections from the inside.

6.5.2 The relays shall be capable of operating continuously between 80 – 120% of auxiliary voltage.

6.5.3 All numerical relays shall have adequate number of freely configurable, optically isolated, Binary Inputs (BI) and potential free Binary Outputs (BO).

6.5.4 All numerical relays shall have minimum four no. of current inputs, three for phase current and one for earth current, suitable for CT secondary current of 1A. The current inputs shall be compatible with both residual connected CT and Core Balance CT (CBCT). In addition, numerical relay in main outgoing feeder shall have three no. of voltage inputs for Under Voltage/Over Voltage protection.

6.5.5 All I/O's shall have galvanic isolation. Analog inputs shall be protected against switching surges and harmonics.

6.5.6 Making, breaking and continuous capacity of the relay contacts shall be adequate enough for the circuits in which they are used.

6.5.7 The numerical relay shall have the following protection functions with at least two independent protection setting groups. The protection functions shall be selectable from any of the IEC characteristic curves.

- (i) Definite time (DT) phase over current protection
- (ii) Inverse Definite Minimum Time (IDMT) phase over current protection
- (iii) Definite time (DT) earth fault current protection
- (iv) Inverse Definite Minimum Time (IDMT) earth fault current protection
- (v) Under Voltage protection
- (vi) Over Voltage protection

6.5.8 Transformer feeder protection relay shall have provision for the following protection functions.

- (i) Buchholz alarm & trip



Bharat Coking Coal Limited

Tender for Design, Engineering, Procurement & Supply, Construction & Erection, Testing, Commissioning, Associated Transmission System and Comprehensive O&M for 5 (Five) Years of 20 MW (AC)/28 MWp (DC) Solar PV Power Plant and connecting Transmission lines at Dugdha Washery, BCCL- Dhanbad



- (ii) Oil Temperature Indicator (OTI) alarm & trip
- (iii) Winding Temperature Indicator (WTI) alarm & trip
- (iv) Pressure Relief Valve (PRV) trip
- (v) Magnetic Oil Gauge (MOG) alarm

6.5.9 All numerical relays shall have provision for measurement and storage of electrical parameters such as voltage, current, frequency, active power, reactive power etc.

6.5.10 The numerical relay shall be able to record faults and events in non-volatile memory.

- (i) Fault record – At least 5 recent faults including the protection function operated, operating phase(s), voltages and currents along with date and time stamp.
- (ii) Event record – At least 200 events with date and time stamp.

6.5.11 The numerical relay shall have trip circuit supervision facility to monitor the circuit breaker trip circuit both in pre-trip and post-trip conditions. The relay shall also be able to provide circuit breaker monitoring, CT and VT supervision.

6.5.12 The numerical relay shall have self-diagnostic feature with separate output contact for indication of any internal relay failure.

6.5.13 The numerical relay shall have RS-232/RS-485/RJ-45/USB ports on front side for local communication with PC and on rear side for remote communication to SCADA system.

6.5.14 The numerical relay shall have feature for time synchronization through the SCADA System / networking.

6.5.15 The numerical relay shall be provided with backlit alphanumeric LCD to access protection settings, measurement parameters, fault and event records. Read and write access to protection settings shall be password protected.

6.6 Instrument Transformers

6.6.1 Instrument transformers shall be completely encapsulated cast resin type, suitable for continuous operation at the ambient temperature prevailing inside the switchgear enclosure, when the switchgear is operating at its rated load and the outside ambient temperature is 50°C.

6.6.2 Polarity marks shall indelibly be marked on each instrument transformer and at the lead terminals at the associated terminal block.

6.6.3 Voltage transformers shall be single phase units. Bus voltage transformers shall be housed in a separate panel on withdrawable truck.



Bharat Coking Coal Limited

Tender for Design, Engineering, Procurement & Supply, Construction & Erection, Testing, Commissioning, Associated Transmission System and Comprehensive O&M for 5 (Five) Years of 20 MW (AC)/28 MWp (DC) Solar PV Power Plant and connecting Transmission lines at Dugdha Washery, BCCL- Dhanbad



6.6.4 HRC fuses of suitable rating shall be provided on primary side of voltage transformers. For secondary side, four pole Miniature Circuit Breakers (MCB) shall be provided with its supervision facility.

6.7 Earthing

6.7.1 An earth bus made of copper shall be provided throughout the length of the panel. It shall be bolted to the framework of each panel and brazed to each breaker earthing contact bar.

6.7.2 The earth bus shall have sufficient cross section to carry maximum fault current without exceeding the allowable temperature rise.

6.7.3 All non-current carrying conductors of the panel shall be connected to the earth bus. All joints to the earth bus shall be made through at least two bolts. Hinged doors shall be earthed through flexible earthing braid of adequate cross section. Suitable provision shall be provided at each end of the earth bus for connection with Owner's Earth conductor.

6.7.4 Positive earthing of the breaker truck and frame shall be maintained when it is in the connected position and in all other positions whilst the auxiliary circuits are not totally disconnected.

6.7.5 All metallic cases of relays, instruments and other panel mounted equipment shall be connected to earth bus by independent copper wires of size not less than 2.5 sq. mm with green colour insulation.

6.7.6 Instrument transformer secondary neutral point shall be earthed at one place only on the terminal block. Such earthing shall be made through links so that earthing of one circuit may be removed without disturbing the earthing of other circuits.

6.7.7 Separate earthing trucks shall be provided for earthing of busbars and incoming/outgoing feeders. The trucks shall have voltage transformer to indicate presence of voltage prior to earthing. An audible alarm shall also be provided in case of voltage on the earthing terminal. Integral earth switches may also be considered instead of earthing trucks. The earthing truck/switch shall have short circuit withstand capability equal to that of the associated switchgear panel.

6.7.8 The interlocks shall be provided to ensure the following.
(i) It is not possible to rack-in the earthing truck/close the earthing switch when the breaker truck is in SERVICE position.
(ii) It is not possible to rack-in the breaker truck into SERVICE position when earthing truck is connected/earthing switch is in closed position.



Bharat Coking Coal Limited

Tender for Design, Engineering, Procurement & Supply, Construction & Erection, Testing, Commissioning, Associated Transmission System and Comprehensive O&M for 5 (Five) Years of 20 MW (AC)/28 MWp (DC) Solar PV Power Plant and connecting Transmission lines at Dugdha Washery, BCCL- Dhanbad



CNUL

6.8 Bus bar

- 6.8.1** Bus bar shall be made of copper or aluminium with uniform cross section throughout their length. They shall be adequately supported on insulators to withstand electrical and mechanical stresses due to specified short circuit current.
- 6.8.2** All bus bars joints shall be thoroughly cleaned and anti-oxide grease shall be applied. Plain and spring washers shall be provided to ensure good contacts at the joints and taps. Wherever aluminium to copper connections are required, suitable bimetallic connectors or clamps shall be used.
- 6.8.3** Bus bars shall be provided with heat shrinkable sleeves of suitable insulation class throughout their length with proper colour coding. All bus bar joints and taps shall be shrouded.
- 6.8.4** Bus bar support insulators shall be made of non-hygroscopic, arc and track resistant, high strength material suitable to withstand stresses due to over voltage and short circuit current.
- 6.8.5** The Contractor shall submit busbar sizing calculation for specified continuous and short time current ratings during detailed engineering.

6.9 Measuring Instruments

- 6.9.1** All the measuring instruments shall be digital, flush mounting type with communication facility.
- 6.9.2** All feeders except main outgoing feeder shall be provided with digital Multi-Function Meter (MFM). Tri Vector Meter (TVM) shall be provided for the main outgoing feeder (in the HT Panel). Accuracy class of MFM shall be 0.2 and that of TVM shall be 0.2S.
- 6.9.3** Measuring instruments shall have provision to display the following parameters.
 - (i) Line and phase voltages
 - (ii) Line and phase currents
 - (iii) Active power, Reactive power, Apparent power
 - (iv) Frequency
 - (v) Power factor
 - (vi) Total Harmonic Distortion (THD)

6.10 Wiring and Terminal blocks

- 6.10.1** All internal wiring shall be done with 650 V grade, 1.5 sq.mm. PVC insulated stranded flexible copper wire. For CT secondary circuits, 2.5 sq.mm copper wire shall be used.
- 6.10.2** Wire terminations shall be made with solderless crimping type tinned copper lugs,



Bharat Coking Coal Limited

Tender for Design, Engineering, Procurement & Supply, Construction & Erection, Testing, Commissioning, Associated Transmission System and Comprehensive O&M for 5 (Five) Years of 20 MW (AC)/28 MWp (DC) Solar PV Power Plant and connecting Transmission lines at Dugdha Washery, BCCL- Dhanbad



CNUL

Which shall firmly grip the conductor. Insulation sleeves shall be provided at all the wire terminations.

- 6.10.3** Printed identification ferrules, marked to correspond with panel wiring diagram shall be provided at both ends of each wire. The ferrules shall be firmly located on each wire so that they cannot move or turn freely on the wire. Wire identification shall be done in accordance with IS 11353.
- 6.10.4** The Contractor shall be solely responsible for the completeness and correctness of the internal wiring and for the proper functioning of the connected equipment.
- 6.10.5** All internal wiring to be connected to the external equipment shall terminate on terminal blocks. Terminal blocks shall be rated for 650 V, 10 A and made of non- inflammable material.
- 6.10.6** CT and VT secondary circuits shall be terminated on stud type, non-disconnecting terminal blocks.
- 6.10.7** At least 10% spare terminals shall be provided on each panel and these spare terminals shall be distributed on all terminal blocks.

6.11 Warranty

The HT panel unit shall be warranted for minimum of 2 (two) years against all material/ manufacturing defects and workmanship.

6.12 Testing and Inspection

6.12.1 Type Tests

The switchgear panel shall be of type tested design. The following type test reports shall be submitted during detailed engineering. The tests should have been conducted on the similar equipment by NABL accredited laboratory.

Test	Standard	Relevant IEC Clause
Switchgear Panel		
Dielectric tests		
Power frequency voltage test	IEC 62271-200	6.2.6.1
Lightning impulse voltage test	IEC 62271-200	6.2.6.2
Dielectric tests on auxiliary and control circuits	IEC 62271-200	6.2.10



Bharat Coking Coal Limited

Tender for Design, Engineering, Procurement & Supply, Construction & Erection, Testing, Commissioning, Associated Transmission System and Comprehensive O&M for 5 (Five) Years of 20 MW (AC)/28 MWp (DC) Solar PV Power Plant and connecting Transmission lines at Dugdha Washery, BCCL- Dhanbad



CNUL

Measurement of the resistance of the main circuit	IEC 62271-200	6.4.1
Temperature-rise tests	IEC 62271-200	6.5
Short-time withstand current and peak withstand current tests	IEC 62271-200	6.6
Verification of the IP coding	IEC 62271-200	6.7.1
Verification of making and breaking capacities	IEC 62271-200	6.101
Mechanical operation test	IEC 62271-200	6.102
Internal arc test	IEC 62271-200	6.106
Circuit Breaker		
Mechanical operation test at ambient air temperature (M2 Class)	IEC 62271-100	6.101.2
Basic short-circuit test-duties	IEC 62271-100	6.106
Relays		
Vibration tests	IEC 60255-21-1	
Shock and bump tests	IEC 60255-21-2	
Seismic tests	IEC 60255-21-3	
Electromagnetic compatibility requirements	IEC 60255-26	
Product safety requirements	IEC 60255-27	
Common requirements	IEC 60255-1	
Functional requirements	Relevant parts of IEC 60255-100 series	
Current Transformers		
Temperature-rise test	IEC 61869-2	7.2.2
Impulse voltage withstand test on primary terminals	IEC 61869-2	7.2.3
Tests for accuracy	IEC 61869-2	7.2.6
Short-time current tests	IEC 61869-2	7.2.201
Voltage Transformer		

20 MW (AC) Solar PV Power Plant at Dugdha, BCCL- Dhanbad, Jharkhand

Tender No.

.....

57 | Page



Bharat Coking Coal Limited

Tender for Design, Engineering, Procurement & Supply, Construction & Erection, Testing, Commissioning, Associated Transmission System and Comprehensive O&M for 5 (Five) Years of 20 MW (AC)/28 MWp (DC) Solar PV Power Plant and connecting Transmission lines at Dugdha Washery, BCCL- Dhanbad



Temperature-rise test	IEC 61869-3	7.2.2
Impulse voltage withstand test on primary terminals	IEC 61869-3	7.2.3
Test for accuracy	IEC 61869-3	7.2.6
Short-circuit withstand capability test	IEC 61869-3	7.2.301

In case the contractor is not able to submit the test reports during detailed engineering, the contractor shall submit the reports of type/special tests either conducted by NABL accredited laboratory or witnessed by Employer.

6.12.2 Routine Tests

Routine tests and acceptance tests shall be as per the Quality Assurance Plan (QAP) approved by the Employer.

7 AC Cables

7.1 Standards and Codes

All AC Cables shall conform to the following standards and codes.

IS 7098	Crosslinked polyethylene insulated PVC sheathed cables, Part 1: For working voltage up to and including 1100 V
IS 7098	Crosslinked Polyethylene Insulated Thermoplastics Sheathed Cables Part 2: for Working Voltages from 3.3 kV up to and Including 33 kV

7.2 All AC cables shall be flame retardant, low smoke (FRLS) type designed to withstand all mechanical, electrical and thermal stresses develop under steady state and transient operating conditions.

7.3 Only terminal cable joints shall be accepted. No cable joint to join two cable ends shall be accepted. However, cable joints may be allowed if the route length is more than maximum available drum length subject to Employer’s approval.

7.4 In addition to manufacturer's identification on cables as per relevant standard, following marking shall also be provided over outer sheath.

- (i) Cable size and voltage grade (ii)

Word 'FRLS' at every metre

- (iii) Sequential marking of length of the cable in metres at every metre



Bharat Coking Coal Limited

Tender for Design, Engineering, Procurement & Supply, Construction & Erection, Testing, Commissioning, Associated Transmission System and Comprehensive O&M for 5 (Five) Years of 20 MW (AC)/28 MWp (DC) Solar PV Power Plant and connecting Transmission lines at Dugdha Washery, BCCL- Dhanbad



- 7.5** Cables shall be sized based on the following considerations: (i) Rated current the equipment
- (ii) Total power loss in LT cable (from inverter to inverter transformer) shall be limited to 0.5%. For HT cables (from inverter transformer to plant take-off point), total power loss shall be limited to 0.5%. The Contactor shall provide power loss calculations in excel sheet.
- (iii) Short circuit withstand capability as per design for 1s.
- (iv) De-rating factors according to laying pattern

7.6 Warranty

All cables shall be warranted for minimum of 1 (one) year against all material/manufacturing defects and workmanship.

7.7 Testing

Type routine and acceptance tests requirements shall be as per relevant standards for all cable sizes.

7.8 Installation

7.8.1 Cable installation shall be as per IS 1255.

7.8.2 Cables within transformer yard and switchyard shall be laid through RCC cable trench with supports.

7.8.3 Cable terminations shall be made with properly crimped lugs and passed through cable glands at the entry & exit point of the cubicles. Bimetallic lugs shall be used for connecting Cu bus bar and Al cables or vice-versa.

7.8.4 All AC cables shall be provided with punched/embossed aluminium tags. The marking shall be done with good quality letter and numbers of proper size so that the cables can be identified easily.

8 **Auxiliary Supply System**

8.1 Scheme for Auxiliary supply system shall be submitted by contractor during detailed engineering for the approval by Employer.

8.2 It shall mainly comprise of auxiliary transformer, AC distribution board(s) (ACDB), Battery & battery charger system, emergency lighting network, Uninterrupted power supply (UPS), distribution cables and metering & protective devices.



Bharat Coking Coal Limited

Tender for Design, Engineering, Procurement & Supply, Construction & Erection, Testing, Commissioning, Associated Transmission System and Comprehensive O&M for 5 (Five) Years of 20 MW (AC)/28 MWp (DC) Solar PV Power Plant and connecting Transmission lines at Dugdha Washery, BCCL- Dhanbad



- 8.3** Auxiliary system shall be provided with two independent sources for reliable auxiliary power supply.
- 8.4** Following consideration shall be taken into account while sizing the auxiliary transformer:
 - (i) 20% future load margin (ii) 20% design margin
 - (iii) Total connected load at 0.8 power factor

9 AC Combiner Box

9.1 Standards and Codes

Standard/Code	Description
IEC 60529	Enclosure ingress protection
IEC 62262	Enclosure impact protection
IEC 61643	Surge protection
IEC 60269	Fuse
IEC 60947-2	Circuit Breaker

9.2 Construction

- 9.2.1** Enclosure shall be made of UV resistant, fire retardant, thermoplastic material. Enclosure degree of protection shall be at least IP 65 and mechanical impact resistance shall be at least IK07.
- 9.2.2** Bus bar shall be made of copper and of sufficient cross section to carry maximum operating current without exceeding the allowable temperature rise. The Contractor shall submit bus bar sizing calculation during detailed engineering.
- 9.2.3** Fuse/MCB/MCCB of suitable rating conforming to relevant IEC standards shall be provided at each input of the combiner box.
- 9.2.4** Moulded Case Circuit Breaker (MCCB) of suitable rating conforming to IEC 60947-2 shall be



Bharat Coking Coal Limited

Tender for Design, Engineering, Procurement & Supply, Construction & Erection, Testing, Commissioning, Associated Transmission System and Comprehensive O&M for 5 (Five) Years of 20 MW (AC)/28 MWp (DC) Solar PV Power Plant and connecting Transmission lines at Dugdha Washery, BCCL- Dhanbad



provided at the output of combiner box for protection and isolation.

9.2.5 Type-II surge protection device (SPD) conforming to IEC 61643 shall be connected between all the three phases and Earth.

9.2.6 Double compression metallic cable gland of suitable size shall be provided for both input and output cables.

9.3 Warranty

9.3.1 AC Combiner Box unit shall be warranted for minimum of 1 (One) year from the date of supply against all material/ manufacturing defects and workmanship.

9.4 Approval

9.4.1 Documents/Drawings

- (i) Guaranteed Technical Particular (GTP) Datasheet
- (ii) Bill of Materials along with the datasheet of each component
- (iii) General Arrangement (GA) drawing
- (iv) Bus bar sizing calculation
- (v) Quality Assurance Plan (QAP)

9.4.2 Test Certificates/Reports

- (i) Test certificates of fuse/MCB/MCCB and SPD
- (ii) Enclosure ingress protection and impact protection test certificates

9.5 Tests

Routine tests and acceptance tests for the assembled unit shall be as per the Quality Assurance Plan (QAP) approved by the Employer.

10 LT Switchgear

10.1 Standards and Codes

All equipment provided under LT switchgear shall comply with latest revisions and amendments of the relevant IEC standards and IS codes. In particular, the switchgear shall comply with the following standards and codes.

Standard/Code	Description
IS/IEC 61439-1	Low-voltage switchgear and control gear assemblies - Part 1: General rules



Bharat Coking Coal Limited

Tender for Design, Engineering, Procurement & Supply, Construction & Erection, Testing, Commissioning, Associated Transmission System and Comprehensive O&M for 5 (Five) Years of 20 MW (AC)/28 MWp (DC) Solar PV Power Plant and connecting Transmission lines at Dugdha Washery, BCCL- Dhanbad



Voltage class and frequency	650V, 50Hz
CT Secondary Current	1 or 5 A
Class of insulation	Class F
Accuracy class & burden	
a) For Protection	5P20, 5VA PS Class for REF and core balance CT (CBCT)
b) For Metering	Class 0.5, 5VA (min)
Minimum primary earth fault current to be detected by CBCT	1 A
Instrument Security Factor for metering CT	5
Voltage transformer (VT)	
Type	Cast Resin
Accuracy class	0.5
Rated Voltage factor	1.1 continuous, 1.5 for 30 seconds
Class of insulation	E or better
Moulded case circuit breaker (MCCB)	
Rated voltage	415 V
Release	Thermal-Magnetic/Microprocessor
Rated current	As per system requirement
Poles	4 poles
Rated insulation level	690 V
Rated ultimate and service short circuit breaking Capacity	As per system requirement
Rated Making capacity (as per system requirement)	2.1 X Short circuit breaking Capacity
Utilization category	A

10.3 Constructional Details

10.3.1 The panel shall be metal enclosed, free standing, floor mounted, modular type with compartmentalized construction having degree of protection of IP 24 (Indoor) and IP54 (outdoor) as per IS/IEC 60529. All doors and covers shall be provided with neoprene gaskets

20 MW (AC) Solar PV Power Plant at Dugdha, BCCL- Dhanbad, Jharkhand

Tender No.

.....

63 | Page



Bharat Coking Coal Limited

Tender for Design, Engineering, Procurement & Supply, Construction & Erection, Testing, Commissioning, Associated Transmission System and Comprehensive O&M for 5 (Five) Years of 20 MW (AC)/28 MWp (DC) Solar PV Power Plant and connecting Transmission lines at Dugdha Washery, BCCL- Dhanbad



to prevent entry of vermin and dust.

- 10.3.2** All switches, push buttons etc. shall be operated front and shall be flush/semi-flush mounted.
- 10.3.3** The panel shall be fabricated from 2 mm CRCA sheet steel for frame & load bearing surfaces. Partitions may be fabricated from 1.6 mm CRCA if no components are mounted on them.
- 10.3.4** Cable entries shall be from bottom. The opening of cable entry shall be covered by 3mm thick gland plates with proper sealing to avoid water and rodent entry.
- 10.3.5** Earthing bus bar of suitable cross section shall be provided throughout the length of panel.
- 10.3.6** The panel shall be duly wired with suitable size of 1.1kV, PVC insulated cable and terminals shall be brought out for cable connections. 10% spare terminals subjected to minimum one of each rating shall be provided on each distribution switchgear. All wire shall have ferrules as per wiring diagram.
- 10.3.7** The panel shall be painted with 2 coats of primer after pre-treatment and 2 coats of Polyurethane / epoxy paint with shade as decided by the Owner.
- 10.3.8** The panel shall be of dead front construction suitable for front operated and back maintained functioning.
- 10.3.9** 240 V, 5 A, 3 pin industrial socket-outlet with ON/OFF switch shall be provided in each panel.
- 10.3.10** Each panel shall be provided with LED lamp rated for 240 V, 50 Hz, single phase AC supply for interior illumination controlled by door switch.
- 10.3.11** Suitable lifting hooks shall be provided for each panel.
- 10.3.12** Each switchgear panel shall be provided with thermostatically controlled space heaters to prevent condensation within the enclosure. The space heater shall be connected to 240 V, 50 Hz, single phase AC supply through suitable switch and fuse.
- 10.3.13** Earth leakage relay with Core balance CTs (CBCT) shall be provided on main incoming feeders having phase CT ratio more than 50/1A. CBCT's shall be circular window type with window size based on the overall diameter of the cables, to be finalized during detailed engineering.

10.4 Warranty

Distribution panels (ACDB and DCDB) shall be warranted for minimum of 1 (one) year against all material/ manufacturing defects and workmanship

10.5 Testing

Routine test and acceptance tests requirements shall be as per relevant standards for all cable

20 MW (AC) Solar PV Power Plant at Dugdha, BCCL- Dhanbad, Jharkhand	<u>Tender No.</u> <u>.....</u>	64 Page
--	--	------------------



Bharat Coking Coal Limited

Tender for Design, Engineering, Procurement & Supply, Construction & Erection, Testing, Commissioning, Associated Transmission System and Comprehensive O&M for 5 (Five) Years of 20 MW (AC)/28 MWp (DC) Solar PV Power Plant and connecting Transmission lines at Dugdha Washery, BCCL- Dhanbad



CNUL

sizes.

11 Uninterrupted Power Supply

11.1 Standards and Codes

Standard/Code	Description
IEC 62040-1	Uninterruptible power systems (UPS) - Part 1: General and safety requirements for UPS
IEC 62040-2	Uninterruptible power systems (UPS) - Part 2: Electromagnetic compatibility (EMC) requirements
IEC 62040-3	Uninterruptible power systems (UPS) - Part 3: Method of specifying the performance and test requirements

11.2 General Requirements

11.2.1 The Uninterrupted Power Supply (UPS) system shall be designed to supply power to following loads (but not limited to).

- (i) Data logger / SCADA
- (ii) Fire Detection/ Alarm Panel
- (iii) HMI of SCADA
- (iv) Emergency Lighting
- (v) Inverter’s Auxiliary supply (if applicable)
- (vi) HT panel auxiliary
- (vii) CCTV

11.2.2 Sizing of UPS shall be done considering the above-mentioned load at power factor of 0.8 lagging inclusive of 10% design margin at 50 °C.

20 MW (AC) Solar PV Power Plant at Dugdha, BCCL- Dhanbad, Jharkhand	<u>Tender No.</u> <u>.....</u>	65 Page
--	--	------------------



Bharat Coking Coal Limited

Tender for Design, Engineering, Procurement & Supply, Construction & Erection, Testing, Commissioning, Associated Transmission System and Comprehensive O&M for 5 (Five) Years of 20 MW (AC)/28 MWp (DC) Solar PV Power Plant and connecting Transmission lines at Dugdha Washery, BCCL- Dhanbad



CNUL

11.3 System Description

11.3.1 The UPS shall automatically provide continuous, regulated AC power to critical loads under normal and abnormal conditions, including loss of input AC power. The UPS system shall consist of the following major equipment.

(i) UPS Module

(a) Insulated Gate Bipolar Transistor (IGBT) Converter **(b)**

Insulated Gate Bipolar Transistor (IGBT) Inverter

(c) Digital Signal Processor (DSP) using Pulse Width Modulation (PWM) for

Direct Digital Control (DDC) of all UPS control and monitoring functions Static

(d) bypass switch

(ii) Battery system for 2 hours

(iii) Battery protective and disconnect device

(iv) Maintenance bypass switch

(v) LCD display panel and LED indications

(vi) Integrated UPS Communications Protocols capable of communicating with SCADA system

11.3.2 The UPS shall meet the following minimum specifications.

Parameter	Specification
Topology	Online double conversion UPS
Input	
Voltage	230 V ± 10% AC
Frequency	50 ± 5 Hz
Power factor	0.95
Output	
Voltage	230V ± 1% AC
Frequency	50 Hz
Power factor	0.8
Battery	
Type	Sealed, Maintenance-Free (AGM) battery



Bharat Coking Coal Limited

Tender for Design, Engineering, Procurement & Supply, Construction & Erection, Testing, Commissioning, Associated Transmission System and Comprehensive O&M for 5 (Five) Years of 20 MW (AC)/28 MWp (DC) Solar PV Power Plant and connecting Transmission lines at Dugdha Washery, BCCL- Dhanbad



Capacity	100% UPS load for 2 hours
Monitoring and communication	
LED Indicators	Load on Inverter, Battery operation, Load on Bypass, Overload, LCD Fault, UPS Fault
Electrical contacts	Closing contacts for each of the following conditions: <ol style="list-style-type: none"> 1. Unit on Battery 2. Low Battery 3. Summary Alarm 4. UPS On 5. Input Fail
Local Display	LCD/ LED
SCADA communications	RS-232 or RS-485 Interface Port
Overall efficiency	>90%
Electrical Protection	Input/ output under voltage, over temperature, overload, Short circuit, battery low trip

11.3.3 The UPS shall be forced air cooled by internally mounted fans. The fans shall be redundant in nature to ensure maximum reliability. The fans shall be easily replaceable without the use of special tools.

11.3.4 Contractor shall provide the Operation & Maintenance Manual and mandatory spareparts list along with the equipment

11.4 Warranty

UPS shall be warranted for minimum of 5 (five) years and batteries shall be warranted for a minimum of 2 (two) years against all material/ manufacturing defects and workmanship

11.5 Tests

11.5.1 Routine tests and acceptance tests on final product shall be done as per QAP approved by the Employer.

11.5.2 On completion of installation and commissioning of the equipment on site tests shall be carried out with the max. available load, which does not exceed the rated continuous load. An on-site test procedure shall be submitted by contractor include a check of controls and indicators after installation of the equipment.



Bharat Coking Coal Limited

Tender for Design, Engineering, Procurement & Supply, Construction & Erection, Testing, Commissioning, Associated Transmission System and Comprehensive O&M for 5 (Five) Years of 20 MW (AC)/28 MWp (DC) Solar PV Power Plant and connecting Transmission lines at Dugdha Washery, BCCL- Dhanbad



12 Battery and Battery Charger

12.1 Standards and Codes

Standard/Code	Description
IEC 60896-22:2004	Stationary lead-acid batteries - Part 22: Valve regulated types - Requirements
IEC 60896-21:2004	Stationary lead-acid batteries - Part 21: Valve regulated types - Methods of test
IS 1652	Specification for stationary cells and batteries, lead acid type (with plant positive plates)
IS 8320	General requirements and methods of tests for lead acid storage batteries.
IS 15549	Stationary Regulated Lead Acid Batteries

12.2 General

110 V DC system (Battery, Battery Charger & DCDB) in accordance with this specification and standards stated herein, shall comprise of the following.

- (i) Sealed Maintenance Free (VRLA) Battery complete with racks & accessories.
- (ii) One No. Float charger.
- (iii) One No. Float cum Boost charger.
- (iv) DC Distribution Board (DCDB)

12.3 Battery

12.3.1 Battery shall be used to supply the following loads with back up of two hours in case of complete power failure:

- (i) Trip and closing coil of HT circuit breaker
- (ii) Spring charging motors for HT circuit breaker
- (iii) Annunciator and Indication circuit of HT panel
- (iv) Auxiliary supply to protection relays

12.3.2 The battery sizing shall account for suitable temperature correction factors, ageing factors of 1.25, design margin of 1.25 & depth of discharge of 80%.

12.3.3 The design of the battery bank and sizing calculation along with the data sheet for the battery and battery charger shall be submitted for approval.



Bharat Coking Coal Limited

Tender for Design, Engineering, Procurement & Supply, Construction & Erection, Testing, Commissioning, Associated Transmission System and Comprehensive O&M for 5 (Five) Years of 20 MW (AC)/28 MWp (DC) Solar PV Power Plant and connecting Transmission lines at Dugdha Washery, BCCL- Dhanbad



12.3.4 Battery voltage – 220V or 110V DC

12.4 Battery Charger

12.4.1 The Float Charger shall be used to supply normal DC loads and float charging current of charged battery. The Float cum Boost charger shall be designed to supply boost charging current requirement of the associated battery as well as to supply normal DC load. After full discharge of battery bank, the Float Cum boost charger shall be capable of charging the battery to its full capacity in 8 hours duration while supplying normal DC load.

12.4.2 The float charger shall have both auto and manual voltage regulation arrangements with provision of selector switch.

12.4.3 Suitable filter circuits shall be provided in all the chargers to limit the ripple content (peak to peak) in the output voltage and current to 2% and 5% respectively.

12.4.4 Digital Outputs shall be configured for connection to the SCADA to monitor the outputs like charger output current, output voltage, float/boost mode, etc.

12.4.5 The charging equipment shall be housed in a free standing, floor mounted compartmentalized panels. Panel shall have provision for bottom cable entry with removable undrilled cable gland plate of 3.0 mm thickness.

12.4.6 The panel shall be of CRCA sheet steel construction having thickness of at least 2.0mm. Degree of protection provided by the enclosure to the internals of charger shall be IP-42.

12.4.7 The instruments, switches and indicating lamps shall be flush mounted on the front panel.

12.5 DC distribution board (DCDB)

12.5.1 DCDB shall be an integral part of a battery charger.

12.5.2 Doors and covers shall be provided with neoprene gaskets to prevent entry of vermin and dust. Also, door shall be provided with lock and key arrangement to prevent unauthorized access to the board.

12.5.3 DCDB shall have adequate number of outgoing feeders with double pole, DC MCBs. At least 20% feeders shall be provided as spare.

12.6 Warranty

Batteries and battery charger shall be warranted for minimum of 2 (two) years against all material/ manufacturing defects and workmanship.

12.7 Tests

20 MW (AC) Solar PV Power Plant at Dugdha, BCCL- Dhanbad, Jharkhand	<u>Tender No.</u> <u>.....</u>	69 Page
--	--	------------------



Bharat Coking Coal Limited

Tender for Design, Engineering, Procurement & Supply, Construction & Erection, Testing, Commissioning, Associated Transmission System and Comprehensive O&M for 5 (Five) Years of 20 MW (AC)/28 MWp (DC) Solar PV Power Plant and connecting Transmission lines at Dugdha Washery, BCCL- Dhanbad



Routine tests and acceptance tests shall be as per the Quality Assurance Plan (QAP) approved by the Employer.

13 Earthing

13.1 Standards and Codes

Earthing system shall comply with latest revisions and amendments of the relevant IEC standards and IS codes. In particular, earthing system shall comply with the following standards and codes.

Standard/Code	Description
IS 3043	Code of Practice for Earthing
IEC 62561-2	Requirements for conductors and earth electrodes
IEC 62561-7	Requirements for earthing enhancing compounds
IEEE 80	IEEE Guide for Safety in AC Substation Grounding
IEEE 142	IEEE Recommended Practice for Grounding of Industrial and Commercial Power Systems
Indian Electricity Rules	

13.2 General Requirements

13.2.1 Earthing system shall be designed based on system fault current and soil resistivity value obtained from geo-technical investigation report. Earth grid shall be formed consisting of number of earth electrodes sufficient enough to dissipate the system fault current interconnected by earthing conductors.

13.2.2 The earth electrode shall be made of high tensile low carbon steel rod, molecularly bonded by high conductivity copper on outer surface with coating thickness not less than 250 micron as per relevant standards. Suitable earth enhancing material shall be filled around the electrode to lower the resistance to earth. Inspection chamber and lid shall be provided as per IS 3043.



Bharat Coking Coal Limited

Tender for Design, Engineering, Procurement & Supply, Construction & Erection, Testing, Commissioning, Associated Transmission System and Comprehensive O&M for 5 (Five) Years of 20 MW (AC)/28 MWp (DC) Solar PV Power Plant and connecting Transmission lines at Dugdha Washery, BCCL- Dhanbad



- 13.2.3** Earth conductors shall be made of copper bonded steel or galvanized steel of sufficient cross section to carry the fault current and withstand corrosion.
- 13.2.4** Earth conductors buried in ground shall be laid minimum 600 mm below ground level unless otherwise indicated in the drawing. Back filling material to be placed over buried conductors shall be free from stones and harmful mixtures.
- 13.2.5** Earth electrodes shall not be situated within 1.5m from any building whose installation system is being earthed. Minimum distance between earth electrodes shall be two times the driven depth of the electrode.
- 13.2.6** Transformer yard and switchyard fence shall be connected to the earth grid by one GS flat and gates by flexible lead to the earthed post.
- 13.2.7** All welded connections shall be made by electric arc welding. For rust protection, the welds should be treated with red lead compound and afterwards thickly coated with bitumen compound.

13.3 Earthing of PV array field

- 13.3.1** All PV Modules, Module Mounting Structures (MMS) and String Monitoring Unit (SMU) structures in the PV array field shall be bonded to the earthing system by two distinct connections.
- 13.3.2** Each PV Module frame shall be earthed using copper wire of sufficient cross section. The copper wire shall be connected to the earth hole provided in the module frame using suitable arrangement in line with the manufacturer recommendation. The earthing arrangement shall use stainless washers to prevent galvanic corrosion between aluminium frame and copper wire. In order to achieve effective earthing, serrated washers shall be employed to penetrate the anodization layer of the module frame.
- 13.3.3** Continuous copper earthing wire shall be run to connect a group of modules and both ends of the loop shall be bolted to the DC earth grid using bimetallic lugs and stainless-steel fasteners. The copper earthing wire shall be routed in such a way to avoid physical contact with the module aluminium frame.
- 13.3.4** The connection between MMS and DC earth grid shall be bolted or welded. Portion of the MMS which undergoes welding at site shall be coated with two coats of cold galvanising and anti-corrosion paint afterwards.
- 13.3.5** Earth electrodes of the DC earth grid shall be uniformly distributed throughout the PV array



Bharat Coking Coal Limited

Tender for Design, Engineering, Procurement & Supply, Construction & Erection, Testing, Commissioning, Associated Transmission System and Comprehensive O&M for 5 (Five) Years of 20 MW (AC)/28 MWp (DC) Solar PV Power Plant and connecting Transmission lines at Dugdha Washery, BCCL- Dhanbad



field so that optimum earth resistance is offered to leakage current flowing from any module frame or MMS.

13.3.6 SMU equipment earthing point shall be connected to the DC earth grid using flexible copper cable of sufficient cross section as recommended by the manufacturer. The connection with the DC earth grid shall be done using suitable bimetallic lugs and stainless-steel fasteners.

13.4 PCU Earthing

DC negative bus bar of the PCU shall be earthed to avoid Potential Induced Degradation (PID). DC negative bus bar and PCU equipment earth shall be bonded to the PCU earth bus and connected to earth electrodes through flexible copper cable of sufficient cross section as mentioned by the manufacturer. In case negative earthing provision is not available, suitable anti-PID device shall be provided. The interconnection of PCU earth electrodes with DC earth grid shall be as per PCU manufacturer recommendation.

13.5 Transformer Earthing

13.5.1 Inverter transformer neutral shall be floating, not to be earthed. However, recommendation of inverter manufacturer shall also be taken into account.

13.5.2 Transformer tank, cable box, marshalling box and all other body earth points shall be earthed.

13.5.3 Inverter transformer shield shall be earthed separately using minimum two no. of earth electrodes. Earthing conductor between shield bushing and earth electrodes shall be copper flat of suitable size not less than 25 x 6 mm.

13.5.4 Neutral and body of the auxiliary transformer shall be earthed.

13.6 Inverter Room and Main Control Room Earthing

13.6.1 Metallic enclosure of all electrical equipment inside the inverter room and main control room shall be connected to the earth grid by two separate and distinct connections.

13.6.2 Cable racks and trays shall be connected to the earth grid at minimum two places using galvanized steel flat.

13.6.3 SCADA and other related electronic devices shall be earthed separately using minimum two no. of earth electrodes.

13.7 Switchyard Earthing

The metallic frame work of all switchyard equipment and support structures shall be connected to the earth grid by means of two separate and distinct connections.



Bharat Coking Coal Limited

Tender for Design, Engineering, Procurement & Supply, Construction & Erection, Testing, Commissioning, Associated Transmission System and Comprehensive O&M for 5 (Five) Years of 20 MW (AC)/28 MWp (DC) Solar PV Power Plant and connecting Transmission lines at Dugdha Washery, BCCL- Dhanbad



Switchyard shall be shielded against direct lightning stroke by provision of over head shield wire or earth wire or spikes(masts) or a combination there of as per CEA regulations 2010 (Technical standards)- 42(2)(C).

13.8 Tests

Type test reports for earthing electrode, earth enhancing compound and its associated accessories shall be submitted during detailed engineering for approval.

On completion of installation, continuity of earth conductors and efficiency of all bonds and joints shall be checked. Earth resistance at earth terminations shall be measured and recorded.

The earth plate shall be provided to facilitate its identification and for carrying out periodical inspection.

14 Lightning Protection System

14.1 Lightning Protection System (LPS) for entire plant against direct lightning strokes shall be provided as per IEC 62305:2010 or NFC 17-102:2011 standard consisting of capture head transducer with Piezo electric impact controller (with 1KA to 100 Ka range).

14.2 Protection level for the entire plant shall be Level-I.

14.3 LPS as per IEC 62305

Location of air terminals shall be designed as per rolling sphere method.

14.4 LPS as per NFC 17-102

Lightning Protection System shall consist of following accessories.

Lightning Protection System shall follow and consist of following accessories.

- (i) Early Streamer Emission (ESE) air terminal technology
- (ii) Piezo-Electric Transducer technology based Saint Elmo
- (iii) The ESE lightning conductor shall operate permanently with both POSITIVE & NEGATIVE lightning strikes
- (iv) The lightning conductor shall have no radio active source & shall not depend on any battery or external power supplied for its operation



Bharat Coking Coal Limited

Tender for Design, Engineering, Procurement & Supply, Construction & Erection, Testing, Commissioning, Associated Transmission System and Comprehensive O&M for 5 (Five) Years of 20 MW (AC)/28 MWp (DC) Solar PV Power Plant and connecting Transmission lines at Dugdha Washery, BCCL- Dhanbad



- (v) The capture head should be provided inalterable and good conductor structured to generate a forced air circulation at its tip and its prolongation
- (vi) Highly insulated poly-plastic adaptor to fix the ESE air terminal with the FRP mast
- (vii) Fiberglass Reinforced Plastic (FRP) mast
- (viii) Coupler to connect FRP mast with GI mast
- (ix) GI tubular pole supported on RCC pedestal and foundation structure through Base plate & Anchor bolt assembly
- (x) Down-conductor: PVC insulated flexible copper cable of suitable size complying with EN 50164-2 or equivalent standard. It shall be routed along the mast with suitable fixings and connectors
- (xi) Test joint with each down conductor
- (xii) Lightning event counter complying with EN 50164-6 or equivalent standard. It shall be fixed at suitable height in series with the down conductor.
- (xiii) Earth termination system in accordance with NFC 17-102. Earth electrodes shall comply with the EN 50164-2 or equivalent standard. Earth enhancing compounds complying with EN 50164-7 or equivalent standard, may be used where soil resistivity is higher and making it impossible to achieve system resistance within specified limit.

14.5 Accessories listed above are indicative only and any other fittings or accessories, which are usual or necessary for satisfactory operation of the lightning protection shall be provided by the Contractor without extra charges.

14.6 Necessary foundation/anchoring for holding the lightning mast in position to be made after giving due consideration to shadow on PV array, maximum wind speed and maintenance requirement at site in future.

14.7 The product shall be warranted for minimum of 2 (two) years against all material/manufacturing defects and workmanship.

20 MW (AC) Solar PV Power Plant at Dugdha, BCCL- Dhanbad, Jharkhand

Tender No.
.....

74 | Page



Bharat Coking Coal Limited

Tender for Design, Engineering, Procurement & Supply, Construction & Erection, Testing, Commissioning, Associated Transmission System and Comprehensive O&M for 5 (Five) Years of 20 MW (AC)/28 MWp (DC) Solar PV Power Plant and connecting Transmission lines at Dugdha Washery, BCCL- Dhanbad



14.8 Type test reports as per IEC 62305:2010 or NFC 17-102:2011 shall be submitted during detailed engineering for approval.

15 Communication Cables

15.1 Optical Fibre Cables

15.1.1 Optic Fibre cable shall be galvanized corrugated steel taped armoured, fully water blocked with dielectric central member for outdoor/ indoor application so as to prevent any physical damage.

15.1.2 The cable shall have multiple single-mode or multimode fibres on as required basis so as to avoid the usage of any repeaters.

15.1.3 The outer sheath shall have Flame Retardant, UV resistant properties and are to be identified with the manufacturer's name, year of manufacturing, progressive automatic sequential on-line marking of length in meters at every meter on outer sheath.

15.1.4 The cable core shall have suitable characteristics and strengthening for prevention of damage during pulling.

15.1.5 All testing of the optic fibre cable being supplied shall be as per the relevant IEC, EIA and other international standards.

15.1.6 The Contractor shall ensure that minimum 100% cores are kept as spare in all types of optical fibre cables.

15.1.7 Cables shall be suitable for laying in conduits, ducts, trenches, racks and underground buried installation.

15.1.8 Spliced/ Repaired cables are not acceptable. Penetration of water resistance and impact resistance shall be as per IEC standard.

15.2 Communication Cable (Modbus)

15.2.1 Data (Modbus) Cable to be used shall be shielded type with stranded copper conductor. Cable shall have minimum 2 pair each with conductor size of 0.5 Sq.mm. Cable shall be flame retardant according to IEC 60332-1-2.

15.2.2 Cable shall be tested for Peak working voltage of not less than 300 V and shall be suitable for serial interfaces (RS 422 and RS 485).

15.2.3 Communication cable shall be laid through underground with suitable HDPE ducts.

15.2.4



Bharat Coking Coal Limited

Tender for Design, Engineering, Procurement & Supply, Construction & Erection, Testing, Commissioning, Associated Transmission System and Comprehensive O&M for 5 (Five) Years of 20 MW (AC)/28 MWp (DC) Solar PV Power Plant and connecting Transmission lines at Dugdha Washery, BCCL- Dhanbad



16 SCADA

16.1 General Requirements

16.1.1 The Contractor shall provide complete SCADA system with all accessories, auxiliaries and associated equipment and cables for the safe, efficient and reliable operation and monitoring of entire solar plant and its auxiliary systems.

16.1.2 The Contractor shall provide all the components including, but not limited to, Hardware, Software, Panels, Power Supply, HMI, Laser Printer, Gateway, Networking equipment and associated Cables, firewall etc. needed for the completeness.

16.1.3 SCADA System shall have the provision to perform the following features and/or functions:

- (i)** Web enabled Operator Dashboards: Showing key information on Generation, Performance and Current Status of various equipment in Single Line Diagram (SLD) format with capability to monitor PV array string level parameters.
- (ii)** Real time Data Logging with Integrated Analytics & Reporting: Logging of all parameters - AC, DC, Weather, System Run Hours, Equipment Status and Alarms as well as derived/ calculated/ integrated values. The SCADA User interface shall be customizable and enable Report Generation and Graphical Analysis.
- (iii)** Fault and System Diagnostics with time stamped event logging.
- (iv)** Support for O&M Activities: The interface shall allow integration with Surveillance System(s), Module Cleaning System and various other O&M support systems to provide a Data Analysis and Decision Support System for smooth and efficient Plant Operations.
- (v)** AI based Distributed Analytics for Predictive Maintenance, trend analysis and Alerts.
- (vi)** Generate, store and retrieve user configurable Sequence of Event (SOE) Reports.
- (vii)** Interface with different field equipment in the plant and work seamlessly with field equipment supplied by different companies.
- (viii)** Transfer of plant data reliably, to an Owner designated server or Cloud on any kind of remote network including low bandwidth and wireless links such as 2G/3G/4G/VSAT

(Note: Telecom Lease line connection, if required for transferring data from Plant over internet shall be taken by Contractor in the name of Employer for O&M period)

16.1.4 The Control system shall be designed to operate in non-air-conditioned area. However, the

20 MW (AC) Solar PV Power Plant at Dugdha, BCCL- Dhanbad, Jharkhand	<u>Tender No.</u> <u>.....</u>	76 Page
--	--	------------------



Bharat Coking Coal Limited

Tender for Design, Engineering, Procurement & Supply, Construction & Erection, Testing, Commissioning, Associated Transmission System and Comprehensive O&M for 5 (Five) Years of 20 MW (AC)/28 MWp (DC) Solar PV Power Plant and connecting Transmission lines at Dugdha Washery, BCCL- Dhanbad



CNUL

Contractor shall provide a Package/ Split AC of suitable capacity decided by heat load requirement in SCADA room at Main Control Room.

16.2 Architecture

16.2.1 The SCADA System shall be built over Industrial IoT architecture with integrated Analytics, secure web access, enterprise software and Database.

16.2.2 Data acquisition shall be distributed across MCR and LCRs while plant level data aggregation shall be done in both local and remote server (as specified by Owner).

16.2.3 Analog and Digital IO modules shall have integrated processor for distributed IO processing and control.

16.2.4 Data communication system shall be built over fibre optic cables/ wireless network with high bandwidth TCP/IP communication (Fast Ethernet or 802.11a/b/g/n) across all Inverter and Control Rooms with Internet/Intranet access at Main Control Room. Firewall shall be provided for network security.



16.2.5 Plant SCADA Server shall have Industrial Grade server hardware running SCADA & Monitoring Software with data storage (complete plant data) space for 2 years.

16.2.6 Plant data for monitoring and control operations should be accessible without dependence on external network.

16.2.7 A virtual/cloud server running SCADA & Monitoring Software shall be configured in parallel with Plant Server to enable easy access to plant data from outside the plant without having to login to plant server. Effectively, the plant data shall be replicated in both places i.e. between systems at the Plant Server and Remote Server to provide data redundancy for complete plant data.

Note: Configuration of Cloud server and procurement of associated subscription services shall be in the scope of the EPC Contractor.

16.2.8 Operator Workstation/PC shall be of Industrial Grade for browser-based access to plant data from Plant or remote server. Plant control & SLDC/Utility related operations shall only be initiated through browser-based interface requiring no client software or database to be installed on the Workstation. All critical software and Plant Data shall be installed/stored on local and remote servers only with user access control for protecting the software and data assets from accidental deletion or corruption.

 Bharat Coking Coal Limited	Tender for Design, Engineering, Procurement & Supply, Construction & Erection, Testing, Commissioning, Associated Transmission System and Comprehensive O&M for 5 (Five) Years of 20 MW (AC)/28 MWp (DC) Solar PV Power Plant and connecting Transmission lines at Dugdha Washery, BCCL- Dhanbad	
---	---	---

16.2.9 Internet/Intranet at Plant: Public or private network access shall be provided at the plant through any broadband/VSAT connectivity of 50 Mbps or higher bandwidth. In case no broadband/VSAT connectivity can be provided at the plant, a 3G/4G data card from any Internet Service Provider (ISP) may be provided. SCADA system shall be capable of sending all plant data in real time to the Remote Server.

16.2.10 GPS based Time Synchronization System: The SCADA system shall have a Master/Slave Clock system along with antenna, receiver, cabinet and internal interconnection cables. All SCADA controllers, servers, OWS and communicating equipment shall be synchronized to the GPS clock.

16.3 Industrial IoT Controllers & Data Acquisition

The Plant SCADA and Monitoring System may use one or more IIoT Controllers at each Inverter Control Room and MCR for the purpose of data acquisition and data forwarding to the Local and Remote SCADA Servers. The IIoT Controllers shall meet the following minimum requirements:

16.3.1 The IIoT Controllers shall be distributed in nature and work independently of other IIoT Controllers or any central controller in the system.

16.3.2 Shall be capable of supporting wide range of field protocols to communicate with different field equipment (Modbus over serial RS485 / Ethernet/IEC 61850 /IEC 104 etc) and IIOT protocols http, https, FTP, SNTP, SNMP, SMTP, SQL, MySQL, DCP .

16.3.3 Shall have local storage for a minimum of 2 weeks (in case of network failure).

16.3.4 Provide web-based interface to configure the controller for various equipment in the field.

16.3.5 IO Functionality: Shall support status monitoring of VCBs & Trip relays on RMU/HT/BESS & Transformer panels through distributed DI/AI modules.

16.3.6 Controls: Shall be capable of Controlling breakers (ON/OFF). Both ON/OFF and Parameter control of inverters shall be supported.

16.3.7 Data Communication with Servers: Shall send the data collected, from all the equipment at Inverter Control Room and/or Main Control Room, to the Monitoring & Control Server.

16.3.8 Controllers shall be capable of sending data over Internet connections USB data cards.

16.3.9 IIOT Controller should have min 8 MB programming memory and should support min 8 GB memory expansion.

16.3.10 IIOT Controller should have min 2 Ethernet port on onboard.

16.3.11 Master controller in main control room SCADA shall be provided with two processors (Main processing unit and memories), one for normal operation and one as hot standby. Any fault in primary

20 MW (AC) Solar PV Power Plant at Dugdha, BCCL- Dhanbad, Jharkhand	<u>Tender No.</u> <u>.....</u>	78 Page
--	--	------------------



Bharat Coking Coal Limited

Tender for Design, Engineering, Procurement & Supply, Construction & Erection, Testing, Commissioning, Associated Transmission System and Comprehensive O&M for 5 (Five) Years of 20 MW (AC)/28 MWp (DC) Solar PV Power Plant and connecting Transmission lines at Dugdha Washery, BCCL- Dhanbad



controller there should be bump less transfer to standby controller. Synchronization between primary and secondary controller should be on direct Fiber connectivity.

16.4 Functionalities

- 16.4.1** The SCADA system shall monitor instantaneous and cumulative electrical parameters from all DC & AC Equipment including inverters, string combiner boxes, weather station, MFM, Transformer, BESS, Switchgear (LT & HT Panels) and Plant EMS Controller at regular intervals not greater than one minute.
- 16.4.2** The SCADA system shall monitor Instantaneous and cumulative environment parameters from weather sensors or data loggers as well as BESS parameters at same interval as electrical parameters and provide PR, CUF, State of Charge (SoC) etc. on the fly.
- 16.4.3** The SCADA system shall provide Alarms and Alerts on equipment faults and failure in less than 5 seconds. Alarms on status change of hardwired DI shall also be provided.
- 16.4.4** The SCADA system shall provide configurable alerts on any parameter crossing settable thresholds. The list of such parameters shall be finalised in consultation with the Owner.
- 16.4.5** The SCADA system shall enable integration with other sub-systems at the plant for supporting O&M activities. The list shall include but not limited to:
 - (i) Surveillance Cameras,
 - (ii) Module Cleaning System – For monitoring of water usage and efficacy of cleaning process.
- 16.4.6** The SCADA system shall have user-friendly browser-based User Interface for secure access from anywhere, for minimum ten concurrent connections from the Operator PC or other securely connected laptop/mobile, for plant monitoring, O&M, daily reporting, and analysis. A dashboard providing summary details of total plant generation, day’s export, irradiance, Inverter Control Room level generation and performance indicators like PR and CUF.
- 16.4.7** Reporting: The SCADA system shall provide downloadable reports in Excel/PDF, configurable for equipment parameters across the plant.
- 16.4.8** The system shall have Configurable Analysis page for self-configured as well as on demand Analytics charts.
- 16.4.9** The SCADA system shall be extensible to include maintenance of O&M schedules and related activities for plant equipment as per the O&M Manual.
- 16.4.10** Connectivity shall be provided to Owner’s Data Monitoring Centre. Data collected by Plant

20 MW (AC) Solar PV Power Plant at Dugdha, BCCL- Dhanbad, Jharkhand	<u>Tender No.</u> <u>.....</u>	79 Page
--	--	------------------



Bharat Coking Coal Limited

Tender for Design, Engineering, Procurement & Supply, Construction & Erection, Testing, Commissioning, Associated Transmission System and Comprehensive O&M for 5 (Five) Years of 20 MW (AC)/28 MWp (DC) Solar PV Power Plant and connecting Transmission lines at Dugdha Washery, BCCL- Dhanbad



CNUL

SCADA shall be replicated in real-time, using industry standard interfaces such as Web Services, OPC-UA, data files, as required – with Owner’s Central Monitoring System. The data recording intervals for different parameters from different devices in the solar plant shall be considered when creating schedules to “push” the data from Plant SCADA to Owner’s Data Monitoring Centre.

16.4.11 Mobile User Interface: summary of plant performance and issues should be accessible in a mobile Native UI or browser UI.

16.4.12 Data Communication to SLDC: SCADA system shall provide required interface to integrate with TRANSCO-SLDC, in compliance with grid code, to send any parameters specified by SLDC.

Note: The methodology and specification of SLDC interface will be provided separately by SLDC/TRANSCO and it shall be the responsibility of the Contractor to determine the same.

16.4.13 Power Plant Control: SCADA system shall provide required interface to the local SCADA operator to set various power control modes (active/reactive power/frequency/PF) through the inverters over industry standard communication protocols like Modbus over TCP/IP.

16.4.14 Forecasting and Scheduling: SCADA shall provide day ahead and week ahead forecasting and scheduling for power generation at the plant as per SLDC/Utility stipulations.

16.4.15 Predictive Maintenance: SCADA system shall have in-built or pluggable frameworks to support AI based Predictive Maintenance for all key equipment including inverters, transformers and switchgear at the plant.

16.4.16 All programming functionalities shall be password protected to avoid unauthorized modification.

16.4.17 The Contractor shall provide software locks and passwords to Employer for all operating & application software. Also, the Contractor shall provide sufficient documentation and program listing so that it is possible for the Employer to carry out modification at a later date.

16.5 Earthing

16.5.1 Two isolated electronic earth pits near to SCADA panel at every Inverter and Control Room with < 1 Ohm resistance shall be provided. One earth pit shall be used for protective/body earth and the other to be used for Signal Earth.

16.5.2 Apart from providing separate earth pits, manufacturer specified earthing recommendations



Bharat Coking Coal Limited

Tender for Design, Engineering, Procurement & Supply, Construction & Erection, Testing, Commissioning, Associated Transmission System and Comprehensive O&M for 5 (Five) Years of 20 MW (AC)/28 MWp (DC) Solar PV Power Plant and connecting Transmission lines at Dugdha Washery, BCCL- Dhanbad



shall be followed for all communicating equipment connected to SCADA. This includes but is not limited to SMBs, Inverters, WMS and Switchgear panels.

16.6 Communication Cable Laying

16.6.1 All RS485, IO and CAT6 cables shall be laid in separate conduits with a minimum separation of 1.5ft from AC/DC power cables all along.

16.6.2 Power cables shall be laid deep in the trenches first. Data cables shall be laid in separate conduits after partially filling the trenches to ensure minimum 1.5 ft separation between power and communication cables all along the trench.

16.6.3 IO Cables between switch gear panels and SCADA panel shall be laid on separate cable trays, with a minimum of 1.5ft separation from trays carrying AC Power cables.

16.6.4 RS485 & CAT6 cables between switch gear panels or Inverters and SCADA panel shall be laid on separate cable trays, with a minimum of 1.5ft separation from trays carrying AC Power cables.

16.7 Control Cabinets / Panels / Desks at Main Control Room

16.7.1 The cabinets shall be IP-22 protection class. The Contractor shall ensure that the temperature rise is well within the safe limits for system components even under the worst condition and specification requirements for remote I/O cabinets.

16.7.2 The cabinets shall be totally enclosed, free standing type and shall be constructed with minimum 2 mm thick steel plate frame and 1.6 mm thick CRCA steel sheet or as per supplier's standard practice for similar applications.

16.8 Software Licences

The Contractor shall provide software license for all software being used in Contractor's System. The software licenses shall be provided for the project and shall not be hardware/machine-specific.

16.9 Hardware at Main Control Room

16.9.1 The Hardware as specified shall be based on latest state of the art Workstations and Servers and technology suitable for industrial application & power plant environment.

16.9.2 The Local Monitoring & Control Server and the Operating Work station, to be deployed in the Plant Control Room, shall have the following server hardware and operating system along with accessories:

20 MW (AC) Solar PV Power Plant at Dugdha, BCCL- Dhanbad, Jharkhand	<u>Tender No.</u> <u>.....</u>	81 Page
--	--	------------------



Bharat Coking Coal Limited

Tender for Design, Engineering, Procurement & Supply, Construction & Erection, Testing, Commissioning, Associated Transmission System and Comprehensive O&M for 5 (Five) Years of 20 MW (AC)/28 MWp (DC) Solar PV Power Plant and connecting Transmission lines at Dugdha Washery, BCCL- Dhanbad



CNUL

Plant Server	
Server Hardware	Hex/Octal Core Xeon, 32GB RAM (expandable to 64 GB RAM), 8 X 2TB SATA hard discs in RAID 5 configuration, 4 Nos. of 2TB external USB hard disc (for backup), dual powersupplies, 2 LAN ports, LCD console, keyboard & mouse. The Server hardware shall be housed in a rugged fan-cooled, and rodent-proof Server Rack.
Operating System	Operating System and Database shall be of enterprise scale (RedHat Linux or equivalent Linux OS or Windows OS, Oracle/MySQL or equivalent DB), with required AMC for 5 years.
Accessories	<ol style="list-style-type: none"> 1. Monitor: Min 22" LED Flat Monitor with non-interfaced refresh rate min. 75 Hz. 2. Keyboard: ASCII type 3. Pointing Device: Mouse 4. Intelligent UPS (on line): Minimum 2 hour battery backup.
Operator Workstation	
Hardware	i7 CPU running at 3.0 GHz or faster with 8GB RAM, 500GB hard disk, 32" LED monitor, keyboard and mouse, 4 USB ports, LAN port
Operating System	Windows operating system with necessary tools, anti-virus software.
Accessories	<ol style="list-style-type: none"> 1. Screen Display Unit: Min 50" LED Flat Monitor with wall mounted arrangement for the display of SCADA screen 2. A4 size monochrome laser printer. 3. UPS of required capacity with 2 hour battery backup.

16.9.3 All network components of LAN and Workstations shall be compatible to the LAN, without degrading its performance.

16.10 Factory Acceptance Test (FAT)

FAT procedure shall be submitted by bidder for approval. SCADA shall communicate with all third devices which are part of solar plant and same shall be demonstrated during the FAT.



Bharat Coking Coal Limited

Tender for Design, Engineering, Procurement & Supply, Construction & Erection, Testing, Commissioning, Associated Transmission System and Comprehensive O&M for 5 (Five) Years of 20 MW (AC)/28 MWp (DC) Solar PV Power Plant and connecting Transmission lines at Dugdha Washery, BCCL- Dhanbad



17 Illumination

17.1 Standards and Codes

LED luminaires shall be tested at independent laboratory as per the following test standards.

Standard/Code	Description
LM79-08	Electrical and Photometric Measurements of Solid-State Lighting Products
LM 80-15	Measuring Luminous Flux and Color Maintenance of LED Packages, Arrays and Modules

17.2 General specification

17.2.1 This specification covers design, supply and installation of uniformly Illumination system along the peripheral & internal roads, main control room & inverter rooms, switchyard and other facilities including entry points/gate(s) inside the plant area.

17.2.2 The Contractor shall furnish Guaranteed Technical Particulars of the LED luminaires, from renowned brands available in the market for approval of Employer.

17.2.3 Lighting system shall work on the auxiliary supply and same shall be incorporated in auxiliary loads. The Contractor shall provide minimum 20% of total lighting points as emergency lighting points, fed from UPS DB or DCDB as per scheme adopted by the Contractor. Indoor and outdoor emergency lights shall be provided at each inverter room, main control room, security room and main gate.

17.3 Lighting Levels

17.3.1 The average LUX level of 10 lm is to be maintained in switchyard. However, a lux level of 20 lm ((10+10) additional switchable on requirement only) is to be maintained in switchyard on transformer.

17.3.2 The lighting system for outdoor and indoor areas of solar power plant shall be designed in such a way that uniform illumination is achieved. Average LUX level to be maintained in different areas shall be as under:

Area	LUX
Control Room and equipment rooms	300
Office	300
Battery & other rooms	150



Bharat Coking Coal Limited

Tender for Design, Engineering, Procurement & Supply, Construction & Erection, Testing, Commissioning, Associated Transmission System and Comprehensive O&M for 5 (Five) Years of 20 MW (AC)/28 MWp (DC) Solar PV Power Plant and connecting Transmission lines at Dugdha Washery, BCCL- Dhanbad



Internal Roads	4
Transformer yard/Switchyard	20
H – pole and metering point	10

17.3.3 The lighting level shall take into account appropriate light output ratio of luminaires, coefficient of utilization maintenance factor (of 0.7 or less) to take into account deterioration with time and dust deposition and illuminance uniformity [U_o] shall be min 0.3.

17.3.4 Plant boundary/ Peripheral area shall be illuminated with chain-link/Boundary wall post mounted LED floodlights (at every 100m) for area lighting as per following specifications:

Input Voltage	AC 220-240V
Frequency	50Hz~60Hz
LED power Consumption	50 W
LED luminous efficiency	85 Lm /W
Led Luminous Flux	4500 lm
lamp's Efficiency	> 88 %
Color Temperature	Cool White
Color Rendering Index	> 75
Light Distribution	Symmetric / circular spot
Light Design	LED+ Reflector
LED Junction Temperature	≤80°C
Working Temperature	-40°C ~ 55°C
IP Grade	IP65
Mechanical Strength	IK08
Working Life-span	30000 Hrs
Certification	CE& ROHS
Warranty	3 Years Product Replacement

17.4 LED Luminaire for Outdoor Applications (Other than Peripheral Area)

17.4.1 LED luminaires shall meet the following parameters.



Bharat Coking Coal Limited

Tender for Design, Engineering, Procurement & Supply, Construction & Erection, Testing, Commissioning, Associated Transmission System and Comprehensive O&M for 5 (Five) Years of 20 MW (AC)/28 MWp (DC) Solar PV Power Plant and connecting Transmission lines at Dugdha Washery, BCCL- Dhanbad



Parameter	Specified Value
Input voltage	170 - 260 V
Input Frequency	50 Hz +/-1 Hz
Power Factor	0.90 (Minimum)
Luminaire efficacy	> 90 lumens per watt
Beam Angle	Minimum 120°
Total Harmonic Distortion	< 10 %
Working Humidity	10% - 90% RH (Preferably Hermetically sealed unit)

Degree of Protection	Minimum IP 65 (for Outdoor fixtures)
Luminaire Casing	Powder coated metal / Aluminium.
Colour Temperature	5700 K (cool day light)
Colour Rendering Index	> 65
Moisture protection in case of casing damage	IP 65 (driver unit shall preferably be totally encapsulated)

- 17.4.2** The LED luminaire (outdoor) housing, heat sink, pole mounting bracket, individual LED reflectors and front heat resistant tempered glass should be provided.
- 17.4.3** The LED luminaire (outdoor) housing should be made of non-corrosive, high- pressure, die-cast aluminium and the housing should be power coated grey, so as to ensure good weatherability. Each individual LED source should be provided with an asymmetrical distribution high reflectance aluminized reflector, which should ensure that the light distribution of the luminaire is suitable for road lighting applications (widebeam distribution) and should ensure high pole to pole spacing.
- 17.4.4** The luminaire should be provided with in-built power unit and electronic driver.
- 17.4.5** The luminaire should be suitable for standard street light poles and should be suitable for side entry and bottom entry (post top).
- 17.4.6** GI Lighting pole of suitable diameter capable of withstanding system and wind load, shall be provided with average Zn coating thickness of 80micron. The street light poles shall have loop in loop out arrangement for cable entry and light fixture / wiring protected with suitably rated MCB.
- 17.4.7** All outdoor lighting system shall be automatically controlled by synchronous timer or photocell. Provision to bypass the timer or photocell shall be provided in the panel.



Bharat Coking Coal Limited

Tender for Design, Engineering, Procurement & Supply, Construction & Erection, Testing, Commissioning, Associated Transmission System and Comprehensive O&M for 5 (Five) Years of 20 MW (AC)/28 MWp (DC) Solar PV Power Plant and connecting Transmission lines at Dugdha Washery, BCCL- Dhanbad



CNUL

17.4.8 Lighting panels shall be earthed by two separate and distinct connections with earthing system. Switch boxes, junction boxes, lighting fixtures, etc. shall be earthed by means of separate earth continuity conductor. Cable armour shall be connected to earthing system at both the ends. Proper earthing of street light poles shall be ensured.

17.4.9 Junction box for lighting shall be made of fire retardant material. The degree of protection shall be IP55 for outdoor JB.

17.4.10 Lighting cables, wherever exposed to direct sunlight, shall be laid through Double Wall Corrugated (DWC) HDPE conduits.

17.5 LED Luminaire/Lamps for Indoor Applications

17.5.1 LED luminaire/lamps shall have minimum 3-star BEE rating.

17.5.2 All indoor LED luminaire/lamps shall be supplied with proper diffuser to avoid direct visibility of LED and suitable heat sink for longer life.

17.6 Warranty

All luminaires shall be warranted against all material/ manufacturing defects and workmanship for minimum of 2 (two) years from the date of supply.

18 **Weather Monitoring System**

As a part of weather monitoring system, the Contractor shall provide the following measuring instruments with all necessary software and hardware required to integrate with SCADA.

18.1 Pyranometer

18.1.1 The Contractor shall provide minimum 2 (two) number of Class-A pyranometers (ISO 9060:2018 classification) along with necessary accessories for measuring incident solar radiation at horizontal and inclined plane of array (POA).

18.1.2 Specification of the pyranometer / albedometer shall be as follows.

Parameter	Specification
Spectral Response (50% points)	0.285 to 2.8 micron
Operating temperature range	0°C to +80°C
Response Time(63%)	<0.7 Sec
Non Stability(change/year)	<0.5%
Non- linearity(100 to 1000W/m2)	<0.2%
Zero offsets(unventilated)	7W/m2



Bharat Coking Coal Limited

Tender for Design, Engineering, Procurement & Supply, Construction & Erection, Testing, Commissioning, Associated Transmission System and Comprehensive O&M for 5 (Five) Years of 20 MW (AC)/28 MWp (DC) Solar PV Power Plant and connecting Transmission lines at Dugdha Washery, BCCL- Dhanbad



a)thermal radiation (@ 200 W/m2)	2W/m2
b) temperature change (5 K/h)	
Detector Type	Thermopile
Accuracy of bubble level	<0.1 Deg
Tilt Response(0 deg to 90 Deg at 1000 W/m2)	<0.2%
Ingress Protection	IP 67

18.1.3 Each instrument shall be supplied with necessary cables. Calibration certificate with calibration traceability to World Radiation Reference (WRR) or World Radiation Centre (WRC) shall be furnished along with the equipment. The signal cable length shall not exceed 20m. The Contractor shall provide instrument manual in hard and soft form.

18.2 Temperature Sensor

The Contractor shall provide minimum 3 (three) temperature sensors (1 (one) for ambient temperature measurement with shielding case and 2 (two) for module temperature measurement). The temperature sensor shall be Resistance TemperatureDetector (RTD) type with measurement range of 0°C to 120°C with IP-65 ingress protection. The instrument shall have valid calibration certificate. Accuracy to be +/- 2 Dec C and resolution at 0.01 Deg C with RS485 Modbus communication output to be considered with 11 plates radiation shield for protection.

18.3 Anemometer

Contractor shall provide minimum one no. Wind Speed sensor/Frequency Proportional to Wind speed/ Ultrasonic and one no. Wind Direction sensor ,Ultrasonic Type / Resistance proportional to wind Direction

Parameter	Specification
Operating Temperature Range	0 Deg C to +70 Deg C
Velocity range with accuracy limit	0-75 m/s with +/-0.3 m/s or +/-3% (0-35m/s) Resolution: 0.01 m/s
Wind direction range with accuracy limit	0 to 360o with <+/-2o accuracy(0-35m/s) Resolution: 1o



Bharat Coking Coal Limited

Tender for Design, Engineering, Procurement & Supply, Construction & Erection, Testing, Commissioning, Associated Transmission System and Comprehensive O&M for 5 (Five) Years of 20 MW (AC)/28 MWp (DC) Solar PV Power Plant and connecting Transmission lines at Dugdha Washery, BCCL- Dhanbad



CNUL

Mounting Bracket	Anodized Aluminium bracket to reduce corrosion, all mounting bolts of SS
Protection Class	IP 66
Output	RS 485
Supply Voltage	12-24 V

18.4 Data logger and Data Acquisition System

Data logger for the weather monitoring station should have the following features:

18.4.1 Provision for analog, digital and counter type inputs for interfacing with various type of sensors

(i) Analog Input

- **Should have modular type structure where input channels can be added based on future requirement.**
- Adequate nos. for all analog sensors with redundancy
- Provision for operation in different current and voltage ranges as per connected sensors
- Accuracy of +/-0.1% of FS

(ii) Digital Inputs

- Adequate no. of Digital inputs and outputs for the application

(iii) Provision for RS232/RS485 serial outputs and TCP-IP outputs

(iv) External battery backup and charging option with Solar Power

(v) Connectivity and Data transmission:

- MODBUS RS485/TCP-IP interface for data collection and
- Storage on SCADA

(vi) Display Settings: Touch Panel with minimum 10.0 cm display with Ingress Protection - IP66(front) which should be easily accessible and should display relevant details like all sensor values, battery strength, network strength etc.



Bharat Coking Coal Limited

Tender for Design, Engineering, Procurement & Supply, Construction & Erection, Testing, Commissioning, Associated Transmission System and Comprehensive O&M for 5 (Five) Years of 20 MW (AC)/28 MWp (DC) Solar PV Power Plant and connecting Transmission lines at Dugdha Washery, BCCL- Dhanbad



(vii) Provision of Time synchronization with the SCADA GPS Synchronisation clock.

(viii) Data Storage: Provision for at least 2 MB internal Flash Memory and at least 2 GB Micro SD card (expandable)

18.4.2 Solution should have sufficient numbers of MCB,SPD and fuse in the data logger

18.4.3 IIOT Protocols in data logger to be maintained- FTP/HTTP/MQTT/SNTP/UDP/TCP and Field Bus Protocol to be maintained – Modbus, Profinet, CAN & OPC

19 CCTV Camera

19.1 CCTV Cameras along with monitoring stations (sufficient numbers) and all other accessories required for its proper operation must be installed to have complete coverage of following areas for 24 hours.

- (i) Main entry: Covering all the entry/exit
- (ii) Along the Plant Perimeter: Covering complete perimeter of Plant Area to capture all possible intrusion
- (iii) Control Rooms: Covering Entry/Exit and Equipment Rooms (iv) Switchyard

19.2 Monitoring stations of the CCTV Network shall be installed in Main Control Room.

19.3 The CCTV system shall be designed as a standalone IP based network architecture. System shall use video signals from different cameras at defined locations, process the video signals for viewing on monitors at control room and simultaneously record all video streams using latest compression techniques.

19.4 Camera shall be colour, suitable for day and night surveillance (even under complete darkness) and network compatible.

19.5 It shall be possible to control all cameras i.e., PTZ auto/ manual focus, selection of pre-sets, video tour selection etc. The software shall support flexible 1/2/4 windows split screen display mode or scroll mode on the display monitor for live video.

19.6 The system shall support video analytics in respect of the following: (i)
Video motion detection

- (ii) Object tracking
- (iii) Object classification

20 MW (AC) Solar PV Power Plant at Dugdha, BCCL- Dhanbad, Jharkhand	<u>Tender No.</u>	89 Page
--	-----------------------------------	------------------



Bharat Coking Coal Limited

Tender for Design, Engineering, Procurement & Supply, Construction & Erection, Testing, Commissioning, Associated Transmission System and Comprehensive O&M for 5 (Five) Years of 20 MW (AC)/28 MWp (DC) Solar PV Power Plant and connecting Transmission lines at Dugdha Washery, BCCL- Dhanbad



(iv) Camera server shall be provided with sufficient storage space to storage recordings of all cameras at HD mode for a period of 15 days. All recordings shall have camera ID, location, date and time of recording.

20 Fire Alarm System

20.1 Standards and Codes

Standard/Code	Description
IS 2189	Selection, Installation and Maintenance of Automatic Fire Detection and Alarm System Code of Practice
IS 2171	Portable Fire Extinguishers, Dry Powder (Cartridge Type)
IS 8149	Functional requirements for twin CO2 fire extinguishers (trolley mounted)
IS 2546	Galvanized mild steel fire bucket
National Building code 2016	

20.2 Contractor shall ensure the compliance of fire detection and alarm system as per relevant standards and regulations. The installation shall meet all applicable statutory requirements and safety regulations of state/central fire department/body or any other competent authority in terms of fire protection.

20.3 Firefighting system for the proposed power plant for fire protection shall be consisting of but not limited to:

- (i) Sand buckets
- (ii) Portable fire extinguishers (CO2 and dry powder type) (iii) Microprocessor based fire alarm panel
- (iv) Multi sensor smoke detectors
- (v) Hooter cum strobe
- (vi) Manual call points



Bharat Coking Coal Limited

Tender for Design, Engineering, Procurement & Supply, Construction & Erection, Testing, Commissioning, Associated Transmission System and Comprehensive O&M for 5 (Five) Years of 20 MW (AC)/28 MWp (DC) Solar PV Power Plant and connecting Transmission lines at Dugdha Washery, BCCL- Dhanbad



(vii) Cables from sensor to fire Panel.

- 20.4** Minimum two numbers of fire extinguishers (CO2 and Foam type each, of capacity 9 kghaving BIS certification marking as per IS: 2171) shall be provided at every building/ encloser, transformer yard and switchyard. However, contractor must comply with existing building code for fire protection and relevant IS codes.
- 20.5** Four numbers of stand with four sand buckets on each stand shall be provided in the Transformer Yard. Sand buckets inside the building shall be provided at strategic locations as decided during detailed engineering.
- 20.6** Digital output from the fire detection system shall be integrated with SCADA
- 20.7** Contractor shall submit the plan for fire and smoke detection system for the Employer's approval.

21 Testing Instruments

The Contractor shall provide the following set of instruments for on-site testing.

21.1 Earth resistance tester

Parameter	Specification
Display	Backlit LCD or LED display
Range	Earth Resistance: up to 2000 Ω Earth Voltage: 200 V
Accuracy	± (2% + 5)
Safety Ratings	IP 56
Accessories	
Earth Ground Stakes – 4 Nos.	
Cable reels – 3 Nos.	
Battery – 2 set	
Carry Case with sufficient space for accommodating accessories	

21.2 Array tester

Parameter	Specification
Display	Backlit LCD or LED display
Functionality	All electrical tests required by IEC 62446-1:2016



Bharat Coking Coal Limited

Tender for Design, Engineering, Procurement & Supply, Construction & Erection, Testing, Commissioning, Associated Transmission System and Comprehensive O&M for 5 (Five) Years of 20 MW (AC)/28 MWp (DC) Solar PV Power Plant and connecting Transmission lines at Dugdha Washery, BCCL- Dhanbad



Memory	Up to 200 records & USB downloadable to Computer
Accessories	
A set of two, 4mm fused leads for extra protection during installation tests	
Leads which enable the array tester to connect directly to PV arrays	
Battery – 2 set	
Carry Case with sufficient space for accommodating accessories	

21.3 Insulation tester

Parameter	Specification
Display	Backlit LCD or LED display
Insulation Test Range	0.1 MΩ to 10 GΩ
Test Voltage	250V, 500V, 1000V, 5000V
Test Voltage accuracy	+20% on positive side only no negative variation is allowed
Accessories	
Heavy duty Test Leads with Alligator Clips – 1 set	
Battery – 2 set	
Carry Case with sufficient space for accommodating accessories	

21.4 Digital Multimeter

Parameter	Specification
Voltage Range	1500 V DC / 1000 V AC (True RMS)
Display	4 ½ digits, Backlit LCD or LED
Measuring Category	1000 V CAT-III as per IEC 61010-1
Additional Functions	Resistance, Temperature, Continuity, Diode, Capacitance, Frequency, Duty cycle measurement
Accessories	

20 MW (AC) Solar PV Power Plant at Dugdha, BCCL- Dhanbad, Jharkhand

Tender No.
.....



Bharat Coking Coal Limited

Tender for Design, Engineering, Procurement & Supply, Construction & Erection, Testing, Commissioning, Associated Transmission System and Comprehensive O&M for 5 (Five) Years of 20 MW (AC)/28 MWp (DC) Solar PV Power Plant and connecting Transmission lines at Dugdha Washery, BCCL- Dhanbad



Temperature Probe – 1
Test Leads with Alligator Clips – 1 set
Battery – 2 set
Carry Case with sufficient space for accommodating accessories.

21.5 Clamp meter

Parameter	Specification
Current Range	400 A DC / 1000 A AC (True RMS)
Display	4 digits, Backlit LCD or LED
Measuring Category	1000 V CAT-III as per IEC 61010-1
Additional Functions	Active, Reactive, Apparent Power, Power Factor and THD
Accessories	
Test Leads – 1 set	
Battery – 2 set	
Carry Case with sufficient space for accommodating accessories.	

21.6 Infra-red thermal imaging camera

Parameter	Specification
Spectral response	8 μm to 14 μm (LW)
Temperature-sensitivity and calibration range	-20 °C to +120 °C
Atmospheric air temperature	-10 °C to +40 °C
Thermal sensitivity	NETD ≤ 0.1 K at 30 °C
Geometric resolution	640 x 480 pixels
Photo camera resolution	Approx. 30 times of IR camera resolution
Absolute error of measurement	< ± 2 K
Adjustable parameters	Emissivity, ambient temperature
Adjustable functions	Focus, temperature level and span



Bharat Coking Coal Limited

Tender for Design, Engineering, Procurement & Supply, Construction & Erection, Testing, Commissioning, Associated Transmission System and Comprehensive O&M for 5 (Five) Years of 20 MW (AC)/28 MWp (DC) Solar PV Power Plant and connecting Transmission lines at Dugdha Washery, BCCL- Dhanbad



CNUL

Measurement functions	Measuring spot, measuring area with average and maximum temperature
Calibration	The measuring system (Camera, lens, aperture and filter): The camera has to be traceably calibrated at least every two years. The calibration has to be documented. If the camera is not compliant, it has to be readjusted by the manufacturer.
Documentation	Storing of the infrared picture with the radiometric data

21.7 Digital lux meter

Parameter	Specification
Range	0 – 1000 lux
Accuracy	± (2% + 5)
Resolution	1 lux
Display	3½ digits, Backlit LCD/LED
Accessories	
Battery – 2 set	
Carry Case with sufficient space for accommodating accessories.	

21.8 All testing equipment shall possess valid calibration certificate issued from approved NABL labs.

21.9 Instruments of superior rating is allowed after seeking consent of the Employer.

21.10 Maintenance, calibration, up keeping, repair & replacement of these tools will be in the scope of the Contractor under the O&M Contract.

21.11 It is Contractor’s responsibility to arrange for tools, tackles, logistics, test kits, manpower, experts etc. required for trouble free operation of Plant.



Bharat Coking Coal Limited

Tender for Design, Engineering, Procurement & Supply, Construction & Erection, Testing, Commissioning, Associated Transmission System and Comprehensive O&M for 5 (Five) Years of 20 MW (AC)/28 MWp (DC) Solar PV Power Plant and connecting Transmission lines at Dugdha Washery, BCCL- Dhanbad



CNUL

22 Power evacuation system

22.1 The contractor has to do the power evacuation and integration to and with the designated substation via either overhead transmission line or underground cables at specified grid voltage with all necessary infrastructure such as protection switchgears and metering systems as per the requirement of the STU/Employer.

22.2 The power evacuation system for the plant shall be as per the state TRANSCO / DISCOM requirement and appropriate approval. The contractor shall get the route approval from the Employer and TRANSCO / DISCOM as the case may be prior to start of the construction. Any changes in the route or scheme introduced by TRANSCO / DISCOM at any point of the time prior to commissioning shall be complied without any additional cost to the Employer.

22.3 The ROW for the TL/UG cable shall be obtained prior to the construction of the line from the concerned authorities.

22.4 Overhead Transmission Line

In case the power evacuation is planned with overhead transmission line for plant internal and external evacuation, the design of tower and its accessories shall be as per the DISCOM’s requirement and the design shall be submitted to Employer for approval/ accord.

22.5 Underground cable

In case the power evacuation is planned with underground cable for plant internal evacuation, the cable shall be approved by the Employer. However, in case of external power evacuation, the evacuation plan shall be as per DISCOM’s requirement and the same shall be submitted to Employer for approval/ accord.

C Civil, Mechanical and Plumbing Works

20 MW (AC) Solar PV Power Plant at Dugdha, BCCL- Dhanbad, Jharkhand	<u>Tender No.</u>	95 Page
--	--	------------------



Bharat Coking Coal Limited

Tender for Design, Engineering, Procurement & Supply, Construction & Erection, Testing, Commissioning, Associated Transmission System and Comprehensive O&M for 5 (Five) Years of 20 MW (AC)/28 MWp (DC) Solar PV Power Plant and connecting Transmission lines at Dugdha Washery, BCCL- Dhanbad



1 General Requirement

1.1 This section of Technical Specifications describes detailed technical and functional requirements of all civil, structural, mechanical & plumbing works included in the scope.

1.2 This excludes design, supply and installation of Galvanised 220 kV and 132 kV Transmission Line towers, Tower extensions & accessories and 11 kV, 22 kV & 33 kV transmission poles & accessories which shall be designed following latest guidelines of respective SEB (State electricity board) and got approved from SEB/STU before execution. In absence of SEB/ STU guidelines REC (Rural electrification corporation) standards shall be followed. Poles at corner with angle > 100 shall be provided with 4-pole structure or lattice tower. Use of Pre-stressed cement concrete spun poles is not acceptable. Approved copies of these designs & drawings shall be submitted to the employer for reference and record.

1.3 Standards & Codes

1.3.1 All design and construction of civil works shall conform to relevant Indian standards such as BIS, IRC, MORTH, NBC etc.

1.3.2 Design of steel structures shall conform to IS: 800, 801 or 802 as applicable. Design of concrete structures shall conform to IS: 456. For design of liquid retaining structure IS: 3370 shall be followed. Only in case of non-availability of Indian standard, equivalent American or British standard may be used for design with prior approval of the Engineer and the contractor shall submit proper justification for the same along with his request to the Engineer for review and approval, and the decision of the Engineer shall be final and binding.

1.3.3 All the design/ drawings shall be prepared/ approved either by in-house Engineering Team of the contractor (or by his Engineering Consultant) with qualified engineering staff with relevant experience in successful design of solar SPV plants.

1.3.4 The design calculations for MMS, RCC structure, Steel structure, Foundation system including piling, Road work, Drainage work, etc. shall be submitted for prior approval of Engineer before commencement of construction.

1.3.5 As per project requirements, the Employer may ask for approval of all civil designs and drawings by a Chartered Civil/ Structural Engineer.

1.4 The design calculations shall be supplemented with a neat sketch showing the structure geometry, node and member nos., lengths of various typical members, support points and type



Bharat Coking Coal Limited

Tender for Design, Engineering, Procurement & Supply, Construction & Erection, Testing, Commissioning, Associated Transmission System and Comprehensive O&M for 5 (Five) Years of 20 MW (AC)/28 MWp (DC) Solar PV Power Plant and connecting Transmission lines at Dugdha Washery, BCCL- Dhanbad



of supports, types of materials & type of sections with properties considered in analysis & design. The report shall also include back-up calculations for various loads adopted in design, brief write-up on primary load cases and design load combinations considered and conclusions on design results (with supporting sketches) for easy reference and clarity. Where a computer program (other than STAAD) is used for analysis and design, the contractor shall include a write-up on the computer program used along with examples for validation check. Design Input (format suitable to the programme used and also in STAAD format) and output file shall also be given in the design report and in soft copy to facilitate its review and approval by the Engineer.

- 1.5** The methodology for construction of MMS and its foundations, Road & drainage works and Procedure for pile load test shall also be submitted for prior approval of Engineer before start of these works.

2 Topographical Survey

- 2.1** The contractor shall be responsible for detailed Topographical Survey of the proposed project site. The work shall be carried out through an agency with relevant experience and qualified survey team.
- 2.2** The Topographical survey shall be conducted at 20m x 20m grid, or as directed by the Engineer, only with the help of digital surveying instruments like Total Station/ Auto level.
- 2.3** The Contractor shall carry the Bench Mark from nearest GTS Bench mark or any other established source like Railway station, Permanent PWD/ WRD structure etc. as approved by the Engineer, by fly-levelling and establish two permanent bench marks (PBM) at site. All subsequent transfer of levels shall be carried out with respect to these PBMs. The work shall also include constructing permanent reference pillars (RP) at suitable locations as directed by the Engineer. These reference pillars shall be labelled permanently with their respective coordinates and reduced levels for future use. The Permanent Bench Marks (PBM) and reference pillars (RP) shall be shown on the survey drawings.
- 2.4** While carrying bench mark to the project site, levels shall also be established on the permanent objects like culverts etc. at least on one object in every 1 (one) km if available along with route with adequate description about the objects. These levels shall be maintained at site & also mentioned in the survey report to facilitate locating these objects later on.
- 2.5** The survey work shall be carried out in UTM grid system. The contractor shall also establish the latitudes and longitudes and UTM coordinates of all the corners of the project site. At least



Bharat Coking Coal Limited

Tender for Design, Engineering, Procurement & Supply, Construction & Erection, Testing, Commissioning, Associated Transmission System and Comprehensive O&M for 5 (Five) Years of 20 MW (AC)/28 MWp (DC) Solar PV Power Plant and connecting Transmission lines at Dugdha Washery, BCCL- Dhanbad



50m width of the adjoining plots and surrounding areas shall also be covered in the survey for correlation with adjoining plots and facilities. The grids for the survey work shall be established in N-S & E-W direction (corresponding to Geographical North or Plant North) as directed by the Engineer.

2.6 Positions, both in plan and elevation, of all natural and artificial features in the area like waterways, railway tracks, trees, cultivation, houses, fences, pucca and kutcha roads including culverts and crossings, foot tracks, other permanent objects like telephone posts and transmission towers etc. are to be established and subsequently shown on survey maps by means of conventional symbols (preferably symbols of survey of India Maps). All hills and valleys within the area/areas are to be surveyed and plotted on maps by contours. Any unusual condition or formation on the ground, locations of rock outcrops (if visible on the surface) and springs/falls, sand heap/dune, possible aggregate deposits etc. shall also be noted and plotted on contour maps. The C/L coordinates of existing road & cross drainage (CD) works (culverts etc.) at intermediate points & at corners/ intersections and width of carriage way of the road shall be recorded with their position on the contour maps.

2.7 The record of measurement of all Reduced Levels (RL) shall be submitted in digital format, (in x, y z coordinate system) along with preliminary contour plan of the site, for Engineer's review before submission of final contour map. The contour interval shall be as required for proper representation of the topography however it shall not be more than 0.5m. The Contractor shall submit survey maps of the site in 1:10,000 scale indicating grid lines and contour lines, demarcating all permanent features like roads, railways, waterways, buildings, power lines, natural streams, trees, sand dunes etc. Present use of the site i.e. mining, quarrying, agriculture etc., existing drainage pattern of the site, possibility of water logging and high flood level of the area shall also be captured in the document. The project plot boundary with coordinates of all corner points along with coordinate grid of 50m x 50m interval shall be marked on the contour map.



Bharat Coking Coal Limited

Tender for Design, Engineering, Procurement & Supply, Construction & Erection, Testing, Commissioning, Associated Transmission System and Comprehensive O&M for 5 (Five) Years of 20 MW (AC)/28 MWp (DC) Solar PV Power Plant and connecting Transmission lines at Dugdha Washery, BCCL- Dhanbad



CNUL

3 Geotechnical Investigations

- 3.1** The contractor shall be responsible for detailed Geotechnical investigations at the proposed project site for the purpose of foundation design for various buildings, structures, HT lines, MMS etc. and other design/ planning requirements. The investigation work shall be carried out through any Govt. approved/ NABL accredited agency. The contractor shall submit the credentials of the proposed agency along with relevant certificates in support thereof for verification/ approval of the Investigation Agency by the Engineer.
- 3.2** The scope of work includes execution of complete soil exploration including boring and drilling with rotary drilling rig, standard penetration test (SPT), collecting disturbed (DS) and undisturbed samples (UDS), collecting ground water samples, trial pits, electrical resistivity tests (ERT), field & laboratory CBR tests, conducting laboratory tests on collected samples of soil & ground water and preparation and submission of report. SPT shall be carried out in all types of soil deposits and in all rock formations with core recovery up to 20% met within a borehole (BH). SPT test shall be conducted at every 1.5m interval or at change of strata. The starting depth of SPT shall be 0.5m from ground level. UDS shall be collected at every 1.5m interval or at change of strata. The min. size of trial pit shall be 2.0mx2.0mx2.5m deep.
- 3.3** The field investigations shall mainly include drilling of min. 5m deep BHs (50% of total No. of boreholes shall be 10m deep), conducting SPT and collecting Disturbed (DS) and Undisturbed samples (UDS), conducting in-situ CBR test for approach road to the plant, internal roads & peripheral road; Trial pits (TP) and Electrical resistivity tests (ERT). Number and location of BHs, California bearing ratio (CBR) tests, ERTs and TPs shall be decided as per the project layout, site topography and soil conditions in consultation with the Employer. The proposed locations shall fairly represent the total project site to get the complete required geotechnical information. The BH near MCR and ICR shall be 10m deep. There shall be minimum 1 no. of BH per 5 acres of the area (However, total number of boreholes shall not be less than 5), 3 nos.



Bharat Coking Coal Limited

Tender for Design, Engineering, Procurement & Supply, Construction & Erection, Testing, Commissioning, Associated Transmission System and Comprehensive O&M for 5 (Five) Years of 20 MW (AC)/28 MWp (DC) Solar PV Power Plant and connecting Transmission lines at Dugdha Washery, BCCL- Dhanbad



of Trial pits, 5 nos. of CBR test & ERT, 5 nos. of Ground water samples for laboratory investigations. The soil/ rock samples for laboratory investigations shall be collected from each borehole and trial pit in sufficient nos. (Note- In case the project plot is divided in to number of discrete blocks separated from each other, min. 3 nos. of bore holes, 2 trialpits, 2 ERT and 2 CBR tests shall be taken per such block with at least 1 No. of BHs per 5 acres as specified above).

- 3.4** The proposed Geotechnical investigation plan indicating proposed locations of TPs, BHs, water sample collection points, CBR test & ERT shall be submitted to the Employer for review and approval before start of work.
- 3.5** Laboratory tests shall be conducted on DS & UDS samples and ground water samples in sufficient no. & shall include, Soil classification, Grain size analysis including Hydrometer analysis, determination of Bulk and dry density, Specific gravity, Natural moisture content, Atterberg limits, Tri-axial shear tests (Unconsolidated Undrained – UU) on UDS, Undrained shear test, Consolidation tests, Unconfined compression tests (UCS), Free swell index, chemical analysis of soil and water samples to determine the carbonates, sulphates, chlorides, nitrates, pH, Organic matter and any other chemical harmful to concrete and reinforcement/ steel. Laboratory tests on rock samples shall be carried out for Hardness, Specific Gravity, Unit Weight, Uniaxial Compressive Strength (in-situ & saturated), Slake Durability etc. Laboratory CBR test on soaked samples shall also be conducted on min. 5 no. of soil samples to ascertain the suitability of soil for sub-grade and requirement of any treatment of subgrade soil in case of CBR <2% as per IRC requirements.
- 3.6** After completion of field and laboratory work, the contractor shall submit a Geotechnical Investigation Report for Engineer’s approval. All bore log details and lab test results shall be presented in the report as per provisions of relevant BIS standards indicating BH coordinates, Existing GL, Depth of water table, Method of drilling etc. The report shall include a Map showing the locations of various field tests including coordinates, calculations and recommendations for foundation type and safe bearing capacity (SBC) for various Plant buildings (ICR, MCR etc.) and Open installations, Switch Yard structures & Sub-Station (as applicable), Transformer foundation, HT lines (as applicable), MMS foundation etc. corresponding to settlement of 25mm.
- 3.7** The report shall include the study for “Liquefaction potential assessment of the ground and



Bharat Coking Coal Limited

Tender for Design, Engineering, Procurement & Supply, Construction & Erection, Testing, Commissioning, Associated Transmission System and Comprehensive O&M for 5 (Five) Years of 20 MW (AC)/28 MWp (DC) Solar PV Power Plant and connecting Transmission lines at Dugdha Washery, BCCL- Dhanbad



CNUL

suggestions for any ground improvement measures” as required.

- 3.8** The report shall also include ground water analysis (water sample collected from borewell) to ascertain its suitability for construction purposes, recommendations for type of cement, grade of concrete & minimum cement content as per prevalent soil characteristics with respect to presence of aggressive chemicals and environment exposure conditions as per relevant BIS specifications. However, minimum grade of concrete shall be as specified under Cl.14 ‘Concrete Works’.
- 3.9** In case the contractor wishes to adopt concrete pile foundation for MMS supports the Geo-tech. report shall also include the calculations, based on soil properties, for safe pile capacity under direct compression, lateral load and pull out as per IS:2911. For single pile, Lateral load capacity shall be min. of the values obtained as per IS:2911 & Brom’s method corresponding to free pile head. The report shall also include recommendations about type of pile, its depth and dia. to be used.
- 3.9.1** In coastal areas and in marshy or swelling type soil, under reamed or driven precast concrete pile shall be used. In case contractor wishes to use helical piles the design, fabrication and installation shall conform to IBC (International building code).
- 3.9.2** The contractor shall carry out field trials for initial load test on pile to verify the pile design to confirm the safe load carrying capacity under direct compression, Lateral load and Pull out. The min. of the two values (design value as per soil characteristics & field test results) shall be adopted.
- 3.9.3** The nos. of piles to be tested under each category shall be finalized corresponding to geotechnical characteristics at site, plot area etc. However, minimum 5 nos. of piles shall be tested {min. 3 nos. in each block (block size < 25 acre) and min. 5 nos. in each block (block size .25 acres) if the plant site is divided in discrete blocks separated from each other} under each category of load.
- 3.9.4** The locations of test piles shall be distributed over the plant site and to be finalized in consultation with Engineer. In case the MMS column is fixed using base plate- anchor bolt assembly, the adequacy of provided pile reinforcement in job (working) pile corresponding to the set of test loads shall be reviewed by the contractor for any additional requirement of reinforcement and the same shall be provided in the pile to be cast for initial load test.
- 3.9.5** In case the Contractor proposes to embed the Column leg in the pile for fixing, the test pile



Bharat Coking Coal Limited

Tender for Design, Engineering, Procurement & Supply, Construction & Erection, Testing, Commissioning, Associated Transmission System and Comprehensive O&M for 5 (Five) Years of 20 MW (AC)/28 MWp (DC) Solar PV Power Plant and connecting Transmission lines at Dugdha Washery, BCCL- Dhanbad



shall be provided with embedded column leg as per approved design and any dowels as required for application of test load. The drawing for the Test pile shall be submitted to Engineer for his approval before casting the test pile. The load test on pile shall be conducted after min. of 28 days from the date of casting. In case the contractor desires to conduct the test earlier than 28 days, he may use suitable higher-grade concrete or if there is substantial evidence from earlier cube test results on design grade concrete to demonstrate the early gain of required compressive strength prior to application of the test load.

3.9.6 However, under no circumstances the test shall be conducted before 15 days of the date of casting the pile. All the dial gauges and hydraulic jack assembly shall be properly calibrated as per the requirements of relevant BIS standards and valid calibration certificate to this effect from Govt. / NABL accredited Test agency shall be submitted to the Engineer before use.

3.9.7 The contractor shall submit detailed methodology for conducting the tests in line with IS: 2911 (Part 4) for Engineer’s approval before commencement of any test. After completion of these tests the contractor shall compile the test results and submit thereon in a proper format as specified in the BIS standard with recommendations/ conclusions for Engineer’s approval. The pile work shall start only after approval of the final pile design duly verified/ confirmed with initial load test results.

3.10 All buildings and Plinth for Open installations (MCR, ICR etc.), Transformer yard, Switchyard and Sub-station area shall have levelled ground as detailed under Cl. No. 5 below.

4 Other Investigations

4.1 The contractor shall also obtain and study other input data at proposed project site for design of the project from metrological department/ local govt. authorities. This shall include data related to Rainfall, Maximum & Minimum ambient Temperature, Humidity, HFL etc.

4.2 The contractor shall carry out Shadow Analysis at proposed site and accordingly design strings and array layout with optimum use of space, material and man power. In case of large variations in topography (3° to the horizontal) the study shall also include the effect of topographical variations on array layout and MMS structure design adequacy and stability. The contractor shall submit all the details/ design to the Engineer for review/ approval.

4.3 The contractor shall also identify potential quarry areas for coarse and fine aggregate to be used for concrete and shall carry out the concrete mix design for concrete grade to be used in construction of all concrete works (M25 and above) before start of construction. However, for



Bharat Coking Coal Limited

Tender for Design, Engineering, Procurement & Supply, Construction & Erection, Testing, Commissioning, Associated Transmission System and Comprehensive O&M for 5 (Five) Years of 20 MW (AC)/28 MWp (DC) Solar PV Power Plant and connecting Transmission lines at Dugdha Washery, BCCL- Dhanbad



CNUL

piling M25 concrete with nominal mix of (1:1:2) may be used. For grades of concrete less than M25 to be used in PPC works, nominal mix as specified in IS:456 may be used. The concrete mix shall be designed for each source of cement and aggregates as per provisions of IS:10262 Standard and confirmed through 28 days compressive strength of concrete trial mix samples. Target mean strength of concrete for mix design shall be based on σ (standard deviation) = 5.. The concrete mix design shall be carried out through NABL accredited Laboratory or any Govt. agency approved by the Engineer. In case the contractor proposes to use RMC, the same shall conform to IS: 4926. The Contractor shall submit the Concrete mix design proposed to be used by the RMC for review and approval by the Employer. (Reports of periodic quality tests for the supply concrete batch shall be maintained by the RMC supplier as per approved Quality Plan and the same shall be submitted to the Employer for review and record).

5 Area Grading and Land Development

5.1 The Finished Grade Level (FGL) of the proposed plant shall be fixed with reference to the highest flood level (HFL) and surrounding ground profile at proposed site to avoid flooding of plant site. The data regarding HFL at proposed site shall be obtained from the metrological department by the contractor. In case of absence of this data, the contractor shall assess the required information through local site reconnaissance. The area at and around (up to 25m beyond external wall/ area including access road & parking whichever is minimum) all buildings/ plinth for open installations (ICR, MCR etc.), transformer yard and switch-yard shall be uniformly levelled at suitable RL (i.e. FGL) to be finalized considering topography and HFL at site. The minimum plinth level of all buildings/ open installations shall be 450mm above FGL. Module mounting structure foundation/ Pile cap or any other pedestal shall be min. 200mm above FGL. Top of transformer foundation pedestal shall be min, 500mm above the FGL.

5.2 A detailed drawing for site levelling and grading (if necessary) shall be submitted by the contractor before commencement of construction of all buildings, plinth for open installation and transformer/switchyard works. The estimated volume of cutting and filling shall also be marked on the Grading drawings for reference. The final grade level to be adopted for different blocks shall be clearly marked on the Plant Layout/ Array Layout drawing.

5.3 It is envisaged that the MMS are installed on natural/ existing ground without any levelling or grading of the area. Contractor shall accordingly consider the effect of the existing ground slope on the design of MMS structure as specified elsewhere in the specifications. If any ground



Bharat Coking Coal Limited

Tender for Design, Engineering, Procurement & Supply, Construction & Erection, Testing, Commissioning, Associated Transmission System and Comprehensive O&M for 5 (Five) Years of 20 MW (AC)/28 MWp (DC) Solar PV Power Plant and connecting Transmission lines at Dugdha Washery, BCCL- Dhanbad



CNUL

undulations at column locations are observed the same shall be filled up with PCC (1:3:6) up to surrounding ground level immediately after pile installation before start of erection of other MMS members. In case of pile, the PCC fill shall extend min. 500mm outside pile cap all around and remaining area may be filled up with local soil properly compacted.

- 5.4** The contractor is responsible for making the site ready and easily approachable by clearing bushes, felling of trees (mandatory permissions/ licenses/ statutory clearances from competent authorities if required for cutting of trees, blasting or mining operations, disposal of waste material etc. shall be obtained by the contractor), cutting, filling with selected excavated earth or borrowed earth including identifying borrow areas. Except in exceptional cases (with approval of the Engineer), filling shall be made up of cohesive non-swelling material. The filling for levelling/ reclaiming the ground/ area shall be done in layers not more than 150mm of compacted thickness in case of cohesive (clayey) soils and 250mm compacted thickness in case of granular (sandy) soils with compaction up to 95% (of modified proctor density) and 80% (of relative density) respectively. The slope at edge of graded areas shall not be steeper than 1:1.5 (1 Vertical: 1.5 Horizontal) in cutting and 1:2 (1 Vertical: 2 Horizontal) in filling. In case of filling with rock material, the edges shall be provided in line with provisions of relevant BIS standard.
- 5.5** It shall be ensured that the land is grading and levelling is done properly to ensure free flow of surface run-off and the grade levels shall be fixed with respect to high flood level at site, drainage pattern and system requirements. It shall be ensured that the land is used optimally to have maximum solar power generation considering full utilization of the plot areas. It is advisable to follow the natural flow of water at the ground as far as possible for drainage design.
- 5.6** In case the filled up earth is brought from outside the plant or borrow areas (when the material inside plant area is not found suitable for grading work or if directed by the Engineer), the contractor shall carry out all required soil investigations to ascertain the suitability of the borrowed soil for land development and filling purposes. Contractor's scope shall also include arranging land lease, getting all necessary statutory approvals for mining, payment of necessary challan etc. Excess earth, if any, shall be disposed of properly at location as directed by the Engineer.



Bharat Coking Coal Limited

Tender for Design, Engineering, Procurement & Supply, Construction & Erection, Testing, Commissioning, Associated Transmission System and Comprehensive O&M for 5 (Five) Years of 20 MW (AC)/28 MWp (DC) Solar PV Power Plant and connecting Transmission lines at Dugdha Washery, BCCL- Dhanbad



CNUL

6 Roads

6.1 Suitable approach road (as applicable) from nearest public road up to plant Main gate, Access road from Main gate to Main control cum office room (MCR), Internal roads connecting MCR and other facilities/ buildings/ open installations like Local control room(s) (LCR)/ Inverter control room(s) (ICR), Sub-station & Switch yard (as applicable) etc. and peripheral road along inside of the boundary fence/ wall shall be provided for safe and easy transportation of men, material and equipment during construction and maintenance.

6.2 The Approach road connecting nearest public road and the Main gate shall be of 4.0m wide carriage way with 0.5m wide shoulders on either side. The access road connecting Main gate and MCR and internal access road(s) connecting MCR to various facilities/ buildings/ open Installations shall be of 3.0m wide carriage way with 0.5m wide shoulders on either side while the peripheral road shall be of 2.5m wide carriage way with 0.5m shoulders on either side. The top of road (TOR) elevation shall be minimum 150 mm above FGL to avoid flooding of roads during rains. The roads shall be provided with alongside drains as per design requirements of drainage system for effective disposal of storm water and to avoid cross flow of storm water over the road. The roads shall be designed as per IRC SP-72 corresponding to traffic category T3 and critical field CBR value of the subgrade. Shoulder shall be of min. 150mm thickness.

6.3 However, following minimum road section details shall be followed:

(i) Topping: Surface dressing with gravel or gravel-soil mixture conforming to Cl. 402 of MORD specifications for rural roads published by IRC (MORD specs). However, for sites with average annual rainfall > 1500mm, either 2 course surface bituminous dressing conforming to Cl. 505 of MORD specs or 20 mm thick open graded pre-mix carpet + Type – B or Type –C seal coat conforming to Cl. 506 of MORD specs. will be provided.

(ii) Base course WBM (CBR>100%) conforming to Cl. 405 of MORD specs: 75mm compacted thick, Grade III

(iii) Base course WBM (CBR>100%) conforming to Cl. 405 of MORD specs: 75 mm



Bharat Coking Coal Limited

Tender for Design, Engineering, Procurement & Supply, Construction & Erection, Testing, Commissioning, Associated Transmission System and Comprehensive O&M for 5 (Five) Years of 20 MW (AC)/28 MWp (DC) Solar PV Power Plant and connecting Transmission lines at Dugdha Washery, BCCL- Dhanbad



CNUL

compacted thick, Grade II

- (iv) Granular/ gravel sub-base course (CBR>20%), conforming to Cl. 401 of MORD specs: 175 mm compacted thick, compacted to 100% of max dry density
- (v) Compacted subgrade: 300mm thick below sub-base (non-expansive soil with max.dry density > 1.65 kN/m³) conforming to Cl 303 of MORD specs, compacted up to 98% of standard proctor density in layers of 150mm thickness. In case of expansive soils like black cotton soil suitable treatment as per Cl. 403 of MORD specs shall be provided before laying sub-base course.
- (vi) Gravel Shoulders conforming to Cl 407 of MORD specs: 150mm compacted thick, compacted to 100 % of max. dry density

6.4 Soaked CBR value of sub-grade shall not be less than 2%. Where the CBR of the subgrade is less than 2 % a capping layer of 100 mm thickness of material with a minimum CBR of 10 % is to be provided in addition to the sub-base required for CBR of 2 %. When the subgrade is silty or clayey soil and the annual rainfall of the area is more than 1000 mm, a drainage layer of 100 mm over the entire formation width should be provided conforming to the gradation given in Chapter 6 of IRC SP-20. This layer will form a part of the designed thickness of sub-base.

6.5 In case of no-availability of murrum in the nearby areas of the project site, suitable other screening/ blending material for WBM construction may be used conforming to provisions of IRC SP 20.

6.6 The construction of road shall conform to MORD specifications for Rural roads published by IRC.

6.7 Drain, cable or any other crossing shall be provided with RCC box or precast concrete pipe culvert. The culvert design shall conform to relevant IRC standard. The pipes for road culverts shall be of minimum class NP3 conforming to IS 458 with min. soil cover of 750mm above the pipe. In case of soil cushion less than 750mm the pipe shall be provided with 100 mm thick M20 reinforced concrete encasement with 10 dia. reinforcement rods @ 150mm c/c both ways. However, the water supply pipe for module cleaning and service/ drinking water shall be routed through Medium class GI steel pipe of required dia. conforming to IS: 1161.

6.8 Minimum dia. of casing pipe to be used at any facility like electric cable, water pipe line etc. shall be 150mm.

6.9 Maintenance pathways of min. 1.0 m width shall be provided between SPV arrays for easy movement of maintenance staff, tools, equipment and machinery, washing of modules etc. The



Bharat Coking Coal Limited

Tender for Design, Engineering, Procurement & Supply, Construction & Erection, Testing, Commissioning, Associated Transmission System and Comprehensive O&M for 5 (Five) Years of 20 MW (AC)/28 MWp (DC) Solar PV Power Plant and connecting Transmission lines at Dugdha Washery, BCCL- Dhanbad



pathway area shall be generally levelled and well compacted manually/ mechanically. Areas of depression, valley zones or wherever there is noticeable change in topography, shall be levelled using well compacted good earth matching the top finished surface with ground topography/ grade to avoid accumulation of water in the region and allowing its free flow to keep the area devoid of mud/ sludge.

- 6.10** There shall be no peripheral road. However, about 2.5m wide corridor shall be left along inside of the plant boundary suitably maintained clean of any vegetation and shall be provided with adequate illumination for movement of security personnel. Any undulations shall be made good with locally available coarse grained material to have fairly level passage way.
- 6.11** The design and drawings for approach road, all internal roads and culverts shall be submitted to the Engineer for approval before execution.

7 Surface/ Area drainage

- 7.1** The contractor shall design and construct storm water drainage network for smooth disposal of storm water from the plant to the nearest available drainage outlet.
- 7.2** The storm water drainage system shall be designed and planned to ensure no water stagnation in the plant.
- 7.3** The plant drainage system shall be designed for maximum hourly rainfall intensity and relevant time of concentration.
- 7.4** The design shall conform to the provisions of IRC SP 42 and best Industry practices. (The design rainfall shall be taken as max. hourly rainfall at 25 years return period at project site as provided in the Isopluvial map of the relevant subzone annexed with Flood Estimation Reports of Central Water Commission (CWC).
- 7.5** The coefficient of run-off for estimation of design discharge shall be considered as per catchment characteristics, however it shall not be less than 0.6.
- 7.6** The drainage scheme shall be designed considering the plant plot area and the surrounding catchment area contributing to the plant area drainage as per the topography.
- 7.7** The storm water drainage system shall be a network of open surface drains (with rectangular or trapezoidal cross section) and shall generally be designed to follow the natural flow of water and ground contours.
- 7.8** Suitable size plant peripheral drain as per design (min. 500mm wide x 500mm deep) along inside of plant boundary wall/ fence shall be provided for smooth channelization of outside storm



Bharat Coking Coal Limited

Tender for Design, Engineering, Procurement & Supply, Construction & Erection, Testing, Commissioning, Associated Transmission System and Comprehensive O&M for 5 (Five) Years of 20 MW (AC)/28 MWp (DC) Solar PV Power Plant and connecting Transmission lines at Dugdha Washery, BCCL- Dhanbad



water and to avoid flooding in the plant. The size of all internal and road side drains shall not be less than 450mm (bottom width) x 500mm (depth).

- 7.9** All trapezoidal drains shall have side slopes not steeper than 1:1 and shall be lined with either brick or RR masonry/ concrete or stone slabs as suitable to the site conditions. The min. Thickness of the lining shall be 115mm for brick masonry, 75mm for concrete slabs, 150mm for RR masonry and 100mm for stone slabs. The lining shall be in CM (1:4) and the joints shall be raked and pointed with CM (1:3), however, the joints in lining of plant peripheral drain may be left without pointing.
- 7.10** In case of rectangular drain, the thickness of the wall shall be checked against structural stability under action of the design loads as specified in Cl. No. 10.0 'Design Loads'. However, Min. thickness shall be 230mm for brick masonry, 300mm for RR masonry and 125mm for RCC work, except for garland drain around buildings where the min. wall thickness can be 115mm, 200mm and 100mm respectively for brick masonry, RR masonry and RCC work.
- 7.11** The structural design of drains shall be as per provisions of relevant BIS standards and good industry practice.
- 7.12** The drain outfall shall be connected to the nearest existing natural drain(s)/ water body outside plant premises and it shall be ensured that the drainage water shall not re-enter the plant nor encroach/ flood in the adjacent property/ plot.
- 7.13** The proposed drainage scheme along with design calculations and drawings shall be submitted to the Engineer for review/ approval before start of construction.
- 7.14** The contractor shall also explore for providing rain water harvesting system for water conservation by constructing suitable collection wells along the drains or through provision of detention ponds or percolation/recharge pit etc. The scheme for rain water harvesting along with design calculations shall be submitted for approval.



Bharat Coking Coal Limited

Tender for Design, Engineering, Procurement & Supply, Construction & Erection, Testing, Commissioning, Associated Transmission System and Comprehensive O&M for 5 (Five) Years of 20 MW (AC)/28 MWp (DC) Solar PV Power Plant and connecting Transmission lines at Dugdha Washery, BCCL- Dhanbad



8 Peripheral boundary Wall/Fence

8.1 The plant peripheral boundary shall be provided with either Chain link or barbed wire fencing or masonry boundary wall as specified.

8.2 The boundary fence/ wall shall be provided along the Solar PV plant boundary to demarcate the plant boundary and to keep away the unauthorised access to the plant. The fence/ wall shall be provided with Main entry gate. The fencing/ wall shall be with 2.5m height above grade level including 400mm dia. GI concertina wire along with 3 no. of barbed wires on either arm to be fixed on Y shape angle brackets. The main gateshall be min. 6.0m wide (clear) (4.5 m carriage way + 1.5m wicket gate).

8.3 Chain link fencing

8.3.1 The fencing shall be of Chain link (GI or poly coat GI as specified) mesh fabric with internal, corner and stay posts of RCC (min 200mm x 200mm size, M30 grade) or Hot dipped GI angle (min. ISA 75x75x6 mm), as applicable, along with 230 thick brick/300 thick RR masonry toe wall, with 100mm thick M15 PCC foundation (min. width 450mm and min. depth 450 mm below GL).

8.3.2 Intermediate, corner and stay posts shall be supported with min. 300 mm dia. and 850 mm deep (below GL) piles in cement concrete (nominal mix 1:1:2). The columnposts shall be extended in to the pile up to 800mm with 50mm cover at the bottom. The pile shall project 150mm above GL. The toe wall shall project 150mm above GL. The intermediate, corner and stay posts shall be supported by angle struts that shall have the same foundation as that of the main posts.

8.3.3 The brick masonry toe wall shall be plastered with 15thick CM (1:4) plaster on both faces and shall have min. 50 thick PCC (1:2:4) coping finished smooth and projecting 35mm on either side of the wall with top sloping inwards.

8.3.4 Spacing of intermediate posts shall not be more than 2.5m. Every 10th intermediate post shall be provided with a stay post while every corner post shall be provided with two stay posts on



Bharat Coking Coal Limited

Tender for Design, Engineering, Procurement & Supply, Construction & Erection, Testing, Commissioning, Associated Transmission System and Comprehensive O&M for 5 (Five) Years of 20 MW (AC)/28 MWp (DC) Solar PV Power Plant and connecting Transmission lines at Dugdha Washery, BCCL- Dhanbad



CNUL

either side.

- 8.3.5** Joints in RR masonry shall be properly raked and pointed with CM (1:3).
- 8.3.6** In case of pond/ drain crossing the fence, RCC beam of adequate size supported on RCC columns on either side and suitable grill of MS square rods (vertical spacing not more than 150mm) of min. Size 25x25 mm and min. 3 no. horizontal 20 SQ MS rods or 50 mm x 8 mm thick flats secured to RCC beam and columns; shall be provided in place of toe wall for smooth flow of water.
- 8.3.7** The GI chain link mesh fabric (40x40 mm with min. wire gauge 3.15mm, both ends twisted) and fencing shall conform to IS: 2721. Poly coat GI chain link mesh(50x50mm) shall conform to ASTM 668 and fencing shall conform to ASTM 668.
- 8.3.8** Each fence panel, in lieu of tie wire, shall be provided with 35x35x3mm GI edge angle at top and bottom with mesh fabric firmly secured to them and to intermediate support angles.
- 8.3.9** All MS sections shall be painted with 2 coats of epoxy paint of approved make and shade over 2 coats of suitable primer.

8.4 Boundary wall

The boundary wall structure shall be a RCC beam-column structure with wall of either brick (min. 230mm thick), concrete block (min. 200mm thick) or of Pre-cast RCC columns and wall panels (min. 75mm thick). The top of the wall shall be provided with concrete coping (min. 50mm thick with 40mm projection on either side).

8.5 Barbed wire fencing

The details of barbed wire fencing shall be same as those for chain link fencing except providing barbed wires (4mm dia.) in place of chain-link mesh. There shall be 10 no. of barbed wires which shall be equally placed along the fence height. The Barbed wire shall be of type 'Iowa' and class designation 1 with chromate conversion coating and shall conform to IS: 278. Every bay of the fence shall also be provided with one GI diagonal line wire of 4mm dia. conforming to IS: 280.

8.6 Main Gate

- 8.6.1** The Main entry gate of size as specified under clause no. 8.0 (2.5m height) shall be of rugged design with solid MS steel sections (25x25mm). The spacing of vertical members shall not be more than 150 mm.
- 8.6.2** The gate shall be complete with MS flat guide track, castor wheel(s), GI fittings & fixtures



Bharat Coking Coal Limited

Tender for Design, Engineering, Procurement & Supply, Construction & Erection, Testing, Commissioning, Associated Transmission System and Comprehensive O&M for 5 (Five) Years of 20 MW (AC)/28 MWp (DC) Solar PV Power Plant and connecting Transmission lines at Dugdha Washery, BCCL- Dhanbad



CNUL

like hinges, aldrop, locking arrangement, posts etc.

- 8.6.3** The main gate shall be of 2.5m height and shall have 4.5m wide Gate for vehicular movement and an adjacent 1.5m wide wicket gate for pedestrian movement.
- 8.6.4** Area near the main gate extending from 500 mm (min) outside the gate to 2700 mm (min) inside the gate, shall be brought to Top of Road elevation with respect to the approach road at main gate for full width of the gate. This shall be achieved by providing 200 mm thick PCC (1:2:4) over 100 mm thick PCC (1:4:8) further underlain with 300 mm thick well compacted boulder soling with interstices filled with sand, resting over well compacted subgrade.
- 8.6.5** The gate shall be provided with the Project name plate (2.5mx 1m, 3mm thick MS plate). The gate shall be painted with 2 coats of epoxy paint over 2 coats of suitable primer.
- 8.6.6** The column posts of the gate shall be supported through RCC pedestal and footing. Min. depth of foundation shall be 1200mm below NGL.
- 8.7** All design and drawings for peripheral boundary fence/ Wall and Main gate shall be submitted for Engineer's approval before execution.

9 Plant Layout

- 9.1** The contractor shall submit drawing showing proposed Project Plant and SPV module Layout.
- 9.2** The Plant and SPV module layout shall be a comprehensive drawing showing various requirements of the project like, Reference coordinate grid, Geographical and Plant North, Layout of boundary fence including coordinates of all corner points, Location of main entrance gate and any other access gates as per project needs, Block wise FGL, Layout of main approach road to the plant, Internal and peripheral roads, Security Room/ cabin (s), all Buildings and Open installations with coordinates, Temporary Storage yard/ facility to be used by the contractor during construction, Proposed Array layout, Lightening arrester, UG/Over ground water Tank(s), Storm water drains, Corridor for buried cables etc.
- 9.3** The cable corridor shall be laid through clear gap between arrays and shall not be laid below modules for easy maintenance.
- 9.4** All the facilities and buildings shall be presented with suitable Legend.
- 9.5** The drawing shall be in suitable scale to have proper representation of the information.
- 9.6** The Plant & SPV module layout drawing shall be submitted by the contractor for review/approval by the Engineer.

20 MW (AC) Solar PV Power Plant at Dugdha, BCCL- Dhanbad, Jharkhand

Tender No.
.....



Bharat Coking Coal Limited

Tender for Design, Engineering, Procurement & Supply, Construction & Erection, Testing, Commissioning, Associated Transmission System and Comprehensive O&M for 5 (Five) Years of 20 MW (AC)/28 MWp (DC) Solar PV Power Plant and connecting Transmission lines at Dugdha Washery, BCCL- Dhanbad



10 Design Loads

- 10.1** Unless otherwise specified elsewhere, Dead load, Live load, Wind load and Seismic load for buildings and structures shall be considered as per provisions of relevant BIS standards.
- 10.2** The following minimum imposed load as indicated for some of the important areas shall, however be considered for the design. If actual expected load is more than the specified minimum load, then actual load is to be considered.

S. No.	Area	Imposed (Live) Load
1	Roof	1.50 kN/ Sqm
2	Building floors (GF) & Grade Slab	10.00 kN/ Sqm
3	RCC Floors (General)	5.00 kN/ Sqm
4	Outdoor platforms, Stairs, Landing and Balconies, Walkway, Chequered plate & Grating (except cable trench cover)	5.00 kN/ Sqm
5	Road culverts & allied structures over drain & pipe crossings subjected to vehicular traffic	Design for Class – ‘AA’ loading (Wheeled & Tracked both) and check for Class – ‘A’ loading as per IRC Standard
6	Underground structures such as Sump, Pit, Trench, Drain, UG tank etc.	In addition to Earth pressure and Ground water table at FGL, a surcharge of 20kN /Sqm (10kN/Sqm for drains) shall also be considered. The structure shall be designed for following criteria – (a) Inside empty with outside fill+ surcharge and water table at GL & (b) Inside water with no fill & water table outside
7	Pre-cast and chequered plate cover over cable trench	4.00 kN/ Sqm



Bharat Coking Coal Limited

Tender for Design, Engineering, Procurement & Supply, Construction & Erection, Testing, Commissioning, Associated Transmission System and Comprehensive O&M for 5 (Five) Years of 20 MW (AC)/28 MWp (DC) Solar PV Power Plant and connecting Transmission lines at Dugdha Washery, BCCL- Dhanbad



8	Main access & Internal Roads	As per IRC SP 20 corresponding to vehicular traffic of 150 commercial vehicles per day and critical in-field CBR
---	------------------------------	--

10.3 Primary Loads

- (i) Dead Load (DL) (ii) Live Load (LL)
- (iii) Wind Load (WL) – Both along $\pm X$ & $\pm Z$ horizontal direction
- (iv) Seismic Load (EL) – Both along $\pm X$ & $\pm Z$ horizontal direction

10.4 Basic wind speed (V_b) at project site shall be taken as per IS 875 (part-3) unless otherwise specified elsewhere.

10.5 To calculate the design wind speed (V_z), the factors K_1 (probability factor or risk coefficient), K_2 (terrain roughness and height factor) and K_3 (topography factor) shall be considered as per IS 875 (Part-3) (However, minimum values for K_1 , K_2 and K_3 shall be 0.94, 1.0 and 1.0 respectively)

10.6 Topography factor ‘ k_3 ’ shall be taken as 1.0 upto upwards slope of 3° . For topography with upward slope greater than 3° , the value of ‘ k_3 ’ shall be calculated as per Annexure-C of IS 875 (Part-3).

10.7 In case of plant site within 60 km of sea coast, the importance factor for cyclonic region, ‘ k_4 ’ shall be taken as 1.15.

10.8 To calculate the design wind pressure ‘ p_d ’, factors ‘ k_a ’ (area averaging factor) and ‘ k_c ’ (combination factor) shall be taken as 1.0. (The factor ‘ k_d ’ shall be taken as 1.0 in case of plant site within 60km of sea coast).

10.9 The Seismic Load shall be considered corresponding to Earth quake zone at site as per IS: 1893 (Part- 4) with Importance factor 1.5. Ductile detailing as per IS 13920 shall be followed in concrete structures except in case of concrete support structure upto plinth level supporting open installations of inverter transformers and control panels at ICR/LCR, wherein the detailing shall conform to IS 456 and SP 34.

10.10 Notes for MMS Design

10.10.1 WL shall be considered as detailed below for estimation of WL under primary loads:

20 MW (AC) Solar PV Power Plant at Dugdha, BCCL- Dhanbad, Jharkhand	<u>Tender No.</u>	113 Page
--	-----------------------------------	-------------------



Bharat Coking Coal Limited

Tender for Design, Engineering, Procurement & Supply, Construction & Erection, Testing, Commissioning, Associated Transmission System and Comprehensive O&M for 5 (Five) Years of 20 MW (AC)/28 MWp (DC) Solar PV Power Plant and connecting Transmission lines at Dugdha Washery, BCCL- Dhanbad



- (i) WLx (downward), WLz (downward): Load due to positive pressure on design tilt angles of MMS members for wind acting in both ($\pm X, \pm Z$) directions.
- (ii) WLx (upward), WLz (upward): Load due to negative pressure on design tilt angles of MMS members for wind acting in both ($\pm X, \pm Z$) directions.
- (iii) WLx (member load), WLz (member load): Load due to wind action on side (exposed) face of respective MMS members (drag force) for wind acting in both($\pm X, \pm Z$) directions.
 - $\pm WLx$ (member load, transverse to MMS table): Load due to wind action of column, front and back bracing, longitudinal bracing
 - $\pm WLz$ (member load, along length of MMS table): Load due to wind action of column, rafter front and back bracing, longitudinal bracing

10.10.2 For estimation of design wind loads on purlins (Table 8 of IS 875- Part 3), WL (downward) and WL (upward) on modules (laid in the profile of mono slope canopy) shall be applied such that the center of pressure should be at ($0.3 \times$ length of canopy) from windward end (for simplicity, the wind load distribution may be taken as triangular with max. value at windward end). Solidity ratio (\emptyset) shall be taken as 0.5.

10.10.3 In design of MMS (for height of structures less than 10 m from ground), 20% reduction in wind pressure as per Note under Cl. 6.3 of IS 875 – Part 3 is not permitted in case of purlins (members supporting modules), which shall be designed against action of WL corresponding to full wind pressure.

10.11 Design Load combinations

10.11.1 Appropriate Load factors in LSM design for concrete structures and appropriate Factor of safety in WSM design (ASD) for all steel structures including MMS shall be considered as per relevant BIS standard. No increase in permissible stress is permitted in design of MMS.

10.11.2 Following load combinations shall be considered in design: For

- MMS Design:
 - (i) DL+LL
 - (ii) DL+LL \pm WLx (upward) \pm WLx (member load)
 - (iii) DL+LL \pm WLx (downward) \pm WLx (member load)
 - (iv) DL+LL \pm WLz (upward) \pm WLz (member load)
 - (v) DL+LL \pm WLz (downward) \pm WLz (member load)
 - (vi) DL+LL \pm ELx



Bharat Coking Coal Limited

Tender for Design, Engineering, Procurement & Supply, Construction & Erection, Testing, Commissioning, Associated Transmission System and Comprehensive O&M for 5 (Five) Years of 20 MW (AC)/28 MWp (DC) Solar PV Power Plant and connecting Transmission lines at Dugdha Washery, BCCL- Dhanbad



CNUL

(vii) DL+LL ± ELz

- For RCC and Steel structures except MMS:

(i) DL+LL

(ii) DL+LL ± WLx

(iii) DL+LL ± WLz

(iv) DL+LL ± ELx

(v) DL+LL ± ELz

10.11.3 All buildings, structures and foundations shall be designed to withstand loads corresponding to worst design load combination.

11 Foundations (General)

11.1 Contractor shall design all foundations for buildings, equipment, HT line Towers, Switchyard structures, Transformer, MMS & other structures as per relevant BIS standards and recommendations of Geotechnical investigation report.

11.2 No foundation for MMS, buildings, switchyard equipment and structures, sub-stations, HT line towers, transformers, etc. shall rest on filled-up ground. However, minor structures like cable trench, cable rack, pipe pedestal, etc. may rest on filled-up soil with max. safe bearing capacity for design considerations not more than 3 T/Sqm.

11.3 Min. depth of foundation for all buildings and plinth for open installations shall be 1.5 m below NGL. For all other structures, min. depth of foundation shall be 1.0 m unless specified otherwise.

11.4 All foundations of a building shall be founded at same RL (Reduced level) with respect to foundation depth below lowest NGL (Natural ground level) in the building area. The Levels shall be obtained with reference to the already established TBM using digital survey instrument such as Total Station/ Auto Level.

11.5 All design & drawings shall be submitted to the Engineer for approval before execution.



Bharat Coking Coal Limited

Tender for Design, Engineering, Procurement & Supply, Construction & Erection, Testing, Commissioning, Associated Transmission System and Comprehensive O&M for 5 (Five) Years of 20 MW (AC)/28 MWp (DC) Solar PV Power Plant and connecting Transmission lines at Dugdha Washery, BCCL- Dhanbad



CNUL

12 MMS Foundation

12.1 Module mounting structure (MMS) may be supported on isolated/ strip footing or pile foundation.

12.2 Bored cast-in situ, Driven precast or under reamed Concrete pile

12.2.1 In case the contractor proposes to provide bored cast-in-situ concrete pile; the type,dia. and length of pile shall be as per recommendations of Geotechnical investigation report corresponding to prevalent soil characteristics at site. However, the min. dia. and depth of the pile shall be 300mm (Min 350 mm for column depth more than 175mm) and 1800mm respectively except when very hard strata/ rock (N>100) is encountered at a higher level, the pile shall be extended in to the hard strata minimum 1.5 times the diameter of the pile with total depth of the pile not less than 1200mm below cut-off level.

12.2.2 As specified above, the MMS support shall project minimum 200mm above FGL (Finished grade level) to avoid any damage to the MMS column/sub support due to direct contact of rain water/ surface run-off. This shall be ensured through either single stage construction of entire pile length including portion above FGL or by providing a collar (to be cast in second stage) which shall project min. 75mm in planbeyond the pile face and shall extend min. 250mm below GL.

12.2.3 For proper bonding, the surface of first stage concrete shall be made rough by trowelling and cleaning out laitance and cement slurry by using wire brush on the surface of joint immediately after initial setting of concrete. The prepared surface should be clean watered to get saturated dry condition when fresh concrete is placedagainst it. The prepared surface shall be applied with a suitable bonding agent beforeconstruction of pile cap/ collar as required.

12.2.4 In case the column post/stub is supported through base plate-anchor bolt assembly,the same shall only be provided through RCC pile cap to be designed as per provisions of relevant BIS



Bharat Coking Coal Limited

Tender for Design, Engineering, Procurement & Supply, Construction & Erection, Testing, Commissioning, Associated Transmission System and Comprehensive O&M for 5 (Five) Years of 20 MW (AC)/28 MWp (DC) Solar PV Power Plant and connecting Transmission lines at Dugdha Washery, BCCL- Dhanbad



standard with min. clear overhang of 75mm. The pile shall be embedded min. 50mm in the pile cap and the pile reinforcement shall be extended into the pile cap for proper anchorage.

- 12.2.5** In case of collapse of foundation strata during drilling of the pile bore, removable steelliner shall be used to maintain design depth and diameter of the pile for proper concreting.
- 12.2.6** The design & installation of piles shall conform to IS: 2911.
- 12.2.7** The bore shall be free from water before pouring of pile concrete. For under water concreting tremie shall be used.

12.3 Helical/ Screw Pile

- 12.3.1** The design, manufacture, testing and installation of Helical/ Screw pile shall conform to ICB-2009 and Practice Note 28- “**Screw Piles: Guidelines for Design, Construction & Installation**, ISSN 1176-0907 October 2015 (IPENZ Engineers New Zealand)”
- 12.3.2** The design of pile shall be undertaken and verified by a suitably qualified geotechnical or structural Chartered Engineer with experience in the design of helical/screw piles.
- 12.3.3** The pile shall be designed and manufactured in accordance with accepted engineering practice to resist all stresses induced by installation into the ground and service loads.
- 12.3.4** The steel grade for pile shaft, helix plates and other accessories shall be with min. Fy 350 MPa. Min. thickness (BMT) of shaft and helix plate shall be 6 mm and 8 mm respectively in case of coastal installations and soils containing aggressive chemicals and at other project sites it shall be respectively 5 mm and 6 mm. Cap plate and col base plate shall be min. 12 mm thick and of min. grade E-250 conforming to IS:2062.
- 12.3.5** All materials shall be hot dip galvanized conforming to relevant BIS standard with min. thickness of galvanization 80 microns.
- 12.3.6** Wherever the pile shaft is required to be infilled with concrete grout, the same shall be of min. grade M30 (anti shrink).
- 12.3.7** The allowable axial design load (Direct compression & Pull out), Pa, of helical pile shall be the least of the following values:
 - (i) Sum of the areas of the helical bearing plates times the bearing capacity of the soil or rock comprising the bearing stratum.
 - (ii) Capacity determined from well-documented correlations with installation torque.
 - (iii) Load capacity determined from initial load tests.
 - (iv) Axial capacity of pile shaft.



Bharat Coking Coal Limited

Tender for Design, Engineering, Procurement & Supply, Construction & Erection, Testing, Commissioning, Associated Transmission System and Comprehensive O&M for 5 (Five) Years of 20 MW (AC)/28 MWp (DC) Solar PV Power Plant and connecting Transmission lines at Dugdha Washery, BCCL- Dhanbad



- (v) Axial capacity of pile shaft couplings.
- (vi) Sum of the axial capacity of helical bearing plates affixed to pile.

12.3.8 The lateral allowable load capacity of the pile shall be calculated using P-Y analysis and shall be verified with field trials. The allowable design lateral load shall be equal to the min. of (i) the total lateral load producing max. lateral deflection of 5mm and (ii) 50% of the total lateral load at which the lateral displacement increases to 12mm.

12.3.9 Dimensions of the central shaft and the number, size and thickness of helical bearing plates shall be sufficient to support the design loads.

12.3.10 The Design Report shall include following details.

- (i) Design loads
- (ii) Geotechnical Strength Reduction Factors and supporting methodology
- (iii) List of design standards
- (iv) Design methodology and how specific loads such as seismic, lateral and settlement are addressed
- (v) Founding stratum
- (vi) Estimated length
- (vii) Connection design and details between pile shaft & pile cap plate and Col baseplate
- (viii) Pre-production and production load testing to support design including acceptance criteria.

12.3.11 Helical piles shall be installed to specified embedment depth and torsional resistance criteria as per design. The torque applied during installation shall not exceed the maximum allowable installation torque of the helical pile

12.3.12 Special inspections shall be performed continuously during installation of helical pile foundations. The information recorded shall include installation equipment used, pile dimensions, tip elevations, final depth, final installation torque and other pertinent installation data as required.

12.3.13 The installation of piles shall be done by an agency having adequate experience in helical pile construction.

12.3.14 The method statement for pre-production load testing (initial test) and construction of Helical Pile shall be submitted for review and approval. The method statement shall comply following requirements:

20 MW (AC) Solar PV Power Plant at Dugdha, BCCL- Dhanbad, Jharkhand	<u>Tender No.</u>	118 Page
--	-----------------------------------	-------------------



Bharat Coking Coal Limited

Tender for Design, Engineering, Procurement & Supply, Construction & Erection, Testing, Commissioning, Associated Transmission System and Comprehensive O&M for 5 (Five) Years of 20 MW (AC)/28 MWp (DC) Solar PV Power Plant and connecting Transmission lines at Dugdha Washery, BCCL- Dhanbad



CNUL

12.3.14.1 Helical pile pre-production load testing

The Piling Contractor shall provide a method statement for the pre-production loadtesting. The method statement shall be submitted 2 weeks prior to pile installation for testing and shall contain the following information (as a minimum):

- Programme of the testing, detailing the timing and sequence of each load test including any additional investigations proposed
- The general arrangement of the equipment
- A method for measuring the displacement at the head and toe of each test pile
- Template for the Pile load test report
- Confirming the criteria for determining the acceptability of the compression, tension and lateral load tests
- A contingency plan in the event that a load test is deemed not acceptable
- A procedure for verifying the capacity for each individual pile, this may include correlating the installation torque for each pre-production pile with the load test results
- All pile load tests shall be supervised by suitably experienced personnel, who are competent to operate, monitor and record each test throughout its duration. Each pile load test shall be continuously monitored throughout its duration.

12.3.14.2 Helical Pile Construction

The contractor shall provide a method statement for each piling operation to be undertaken in executing the Works. The method statement shall describe all proposed equipment and detail the construction sequence. The method statement shall be submitted with the tender and shall contain the following information (as a minimum):

Programme of the works, detailing the timing and sequence of individual portions of the works

- Full details of the installation plant to be used, including manufacturer's information and proof of servicing/recent upkeep and calibration
- Proposed phasing of excavation/filling operations such that the design stresses in the piles (and any supporting frames) are not exceeded
- The contingency plan to be adopted, to minimize disruption and delay, in the event of encountering obstructions
- Anticipated noise levels (measured in dB) and vibration levels (measured in



Bharat Coking Coal Limited

Tender for Design, Engineering, Procurement & Supply, Construction & Erection, Testing, Commissioning, Associated Transmission System and Comprehensive O&M for 5 (Five) Years of 20 MW (AC)/28 MWp (DC) Solar PV Power Plant and connecting Transmission lines at Dugdha Washery, BCCL- Dhanbad



CNUL

mm/sec) arising from piling operations (if applicable)

- 12.3.15** The Piling Contractor shall nominate a suitably experienced, professionally qualified engineer, as the “Piling Supervisor”.
- 12.3.16** Unless specified else were, the field trials for initial load tests on concrete and helical/screw pile shall conform to IS: 2911 (Part 4) & Practice Note-28 (IPENZ Engineers New Zealand) as applicable. The no. and location of such tests shall be as per the provisions stipulated under Cl. No. 26.8.
- 12.3.17** Contractor shall also carry out routine tests on 0.5 % of the total no. of working/ job piles as per provisions of IS: 2911 (Part 4). In case of unsatisfactory results, min. no. of routine tests may be increased up to 2% of the total no. of working/ job piles as per the directions of the Engineer.

13 Module Mounting Structure (MMS)

- 13.1** The module mounting structure design shall generally follow the existing land profile. The top of the table shall be in one plane.
- 13.2** In MMS analysis the column support shall be assumed at EGL/NGL.
- 13.3** In case of topographical variations more than 3°, the contractor shall carry out detailed study of its effect on array layout, shadow analysis and structural stability of MMS.
- 13.4** The structure shall be designed to allow easy replacement of any module and shall be in line with site requirements.
- 13.5** The MMS stub/ column, rafter, purlin, ties and bracing members shall conform to following Indian standards.
 - IS: 2062 – Hot rolled Medium and High tensile structural steel
 - IS: 811 – Cold formed light gauge structural steel sections
 - IS: 1161 – Steel tubes for structural purposes
 - IS: 4923 – Hollow steel sections for structural use
 - Minimum grade of steel for sections conforming to IS: 811 & IS: 4923 shall be E350 conforming to IS: 2062 and YSt 310 conforming to IS: 1608 respectively.
- 13.6** The contractor can also propose new light gauge structural steel or structural aluminum sections other than specified in IS: 811 subject to approval of the Engineer. In this case the contractor shall submit his proposal stating the technical advantages of the proposed sections for Engineer’s review along with supporting literature and sample design calculations conforming to present



Bharat Coking Coal Limited

Tender for Design, Engineering, Procurement & Supply, Construction & Erection, Testing, Commissioning, Associated Transmission System and Comprehensive O&M for 5 (Five) Years of 20 MW (AC)/28 MWp (DC) Solar PV Power Plant and connecting Transmission lines at Dugdha Washery, BCCL- Dhanbad



CNUL

specifications at the time of bidding.

- 13.7** Aluminum-Zinc Alloy metallic coated steel strip or sheet of grade YS350 and minimum coating class AZ200 conforming to IS 15961 : 2012 may also be used for fabrication of purlin sections. In such a case, all the sections of the base metal exposed after cutting of members and punching of holes shall be provided with sprayed aluminium and zinc coating conforming to IS 5905.
- 13.8** The minimum thickness excluding anti corrosive treatment (BMT) of various elements of MMS structure shall be as following:
 - Stub/ column – 3.15mm,
 - Rafter – 2.5mm &
 - Purlin – Minimum thickness of the purlin section excluding anti corrosive treatment (BMT) shall be 1.5 mm. Aluminum-zinc alloy metallic coated steel strip or sheet of grade YS350 and min. coating class AZ150 conforming to IS-15961:2012 may also be used for fabrication of purlin sections. In such a case, all the sections of the base metal exposed after cutting of members and punching of holes shall be provided with sprayed aluminum and zinc coating conforming to IS-5905.
 - Other members – 2.0 mm
- 13.9** The primary loads and load combinations for design of MMS structure shall be as specified under Clause No. 10. The design shall be done by Working stress method and no increase in allowable stress shall be permitted.
- 13.10** The maximum permissible deflection/ side sway limits for various elements of MMS under serviceability conditions shall be as following:
 - Lateral deflection/ side sway for Column – Span/ 240
 - Vertical deflection for Rafter and Purlin – Span/ 180
 - Lateral deflection for Purlin – Span/240
- 13.11** In case of natural frequency in first mode less than 5 Hz, the design of the MMS structure shall also be checked against dynamic effects of wind as per provisions of IS – 875 (Part-3) using gust factor method.
- 13.12** The purlins shall be provided with min. following tie/sag rods or angles or channels:
 - 1 no., in the mid of each span and shall connect all the purlin members
 - 1 no., diagonal, at each corner in end spans



Bharat Coking Coal Limited

Tender for Design, Engineering, Procurement & Supply, Construction & Erection, Testing, Commissioning, Associated Transmission System and Comprehensive O&M for 5 (Five) Years of 20 MW (AC)/28 MWp (DC) Solar PV Power Plant and connecting Transmission lines at Dugdha Washery, BCCL- Dhanbad



- 13.13** Lateral restraint to compression flange if any due to PV panels is not permitted in purlin design.
- 13.14** The vertical diagonal bracing shall be provided in end spans and every alternate span of each unit (table) of MMS.
- 13.15** MMS shall support SPV modules at a given orientation & tilt and shall absorb and transfer the mechanical loads to the ground properly.
- 13.16** Welding of structure at site shall not be allowed and only bolted connections shall be used.
- 13.17** The MMS structure shall be hot dip galvanized with minimum GSM 610 kg/ sqm and/or minimum coating thickness of 80 microns for protection against corrosion. Galvanization shall conform to IS-2629, 4759 & 4736 as applicable.
- 13.18** It is to ensure that before application of this coating, the steel surface shall be thoroughly cleaned of any paint, grease, rust, scale, acid or alkali or any foreign material likely to interfere with the coating process.
- 13.19** The bidder shall ensure that inner side is also provided with galvanization coating.
- 13.20** The galvanization shall be done after fabrication of members and cutting of holes to ensure galvanization of all cut/ exposed edges.
- 13.21** In case the proposed section is made up of Aluminum, anodized coating shall be Gr. AC25 and shall conform to IS: 1868.
- 13.22** The array structure shall be so designed that it will occupy minimum space without sacrificing the output from SPV panels at the same time.
- 13.23** Two numbers of anti-theft fasteners of stainless steel on two diagonally opposite corners for each module shall be provided. All fasteners both for MMS connections and fixing of PV Module shall be adequately protected from atmosphere and weather prevailing in the area.
- 13.24** Fasteners and washers to be used for erection of mounting structures and those for fixing Module over MMS shall be of stainless steel grade SS 304 with property class A2-70 conforming to relevant ISO standard and must sustain the adverse climatic conditions to ensure the life of the structure for 25 years.
- 13.25** Min. diameter of bolt for MMS connections shall be 10mm (12 mm in case of single bolt connection for seasonal tilt) except at column-rafter connection, where it shall not be less than 12mm (not less than 16mm in case of single bolt connection for seasonal tilt). In case of fixed tilt, min. two number of bolts shall be provided at each joint.
- 13.26** Modules shall be clamped or bolted with the structure properly. The material of clamp shall be



Bharat Coking Coal Limited

Tender for Design, Engineering, Procurement & Supply, Construction & Erection, Testing, Commissioning, Associated Transmission System and Comprehensive O&M for 5 (Five) Years of 20 MW (AC)/28 MWp (DC) Solar PV Power Plant and connecting Transmission lines at Dugdha Washery, BCCL- Dhanbad



Al / SS having weather resistant properties. Clamp/bolt shall have EPDM rubber washer and shall be designed in such a way so as not to cast any shadow on the active part of a module.

- 13.27** The MMS foundation shall be designed as per Cl. No. 12.
- 13.28** MMS column post supported with base plate secured to foundation shall be fixed with galvanized high strength “J” bolts conforming to specifications of IS: 4000/ IS: 1367 and relevant IS code. Installation of foundation bolts and embedment of column leg in foundation concrete shall be done by using template to ensure proper alignment. The underside of base plate shall be provided with anti- shrink grout.
- 13.29** In case the contractor proposes to extend the column leg to embed it in the pile/pedestal as an alternate fixing arrangement, the column member shall be extended for full depth of the pile (100mm cover at tip of the pile) with an end plate of min. 4mm thickness to be welded at the bottom of column leg. (However, for plants in coastal area or in case of marshy soil the column post shall be supported only with base secured to foundation through base plate and anchor bolt assembly and no embedment of column leg in foundation is permitted)
- 13.30** The array structure shall be grounded properly using maintenance free earthing kit.
- 13.31** The bidder/manufacturer shall specify installation details of the PV modules and the support structures with appropriate diagram and drawings.
- 13.32** The Bidder should design the structure height considering highest flood level at the site and the finished grade level. The minimum clearance between the lower edge of the module and the finished grade shall be the higher of (i) Highest flood level + 100mm and (ii) 500 mm, as applicable
- 13.33** The length of one unit (Table) of MMS shall not generally be more than 20m.
- 13.34** The contractor shall submit the detailed design calculations and drawings for MMS structure, bill of materials and their specifications/ standards to the Employer for approval before start of fabrication work as per the engineering work program (L2 schedule) as finalized during kick-off meeting.
- 13.35** The length of any cold formed section (CFS) shall not be more than 5.5 m.
- 13.36** In case of seasonal tilt, the front and back bracing members (subject to seasonal rotation) shall be connected to rafter or column through gusset plate and shall not be connected directly to the column or rafter.
- 13.37** The purlin splice shall be near the zone of contra-flexure, i.e. within a distance of 0.15L to 0.25L



Bharat Coking Coal Limited

Tender for Design, Engineering, Procurement & Supply, Construction & Erection, Testing, Commissioning, Associated Transmission System and Comprehensive O&M for 5 (Five) Years of 20 MW (AC)/28 MWp (DC) Solar PV Power Plant and connecting Transmission lines at Dugdha Washery, BCCL- Dhanbad



from the support, where L is the respective span within which splicing is located.

13.38 The purlin splice shall comprise of flange and web splice plates and splice design shall conform to Annexure-F of BIS:800. For simplicity in fabrication, the splice member may be of CFS channel section without lips (CU). There shall be min. four number of bolts on either sides of joints in web zones and one number of bolt on either side of joint in flange zones.

13.39 For same member type, same section shall be used.

13.40 When any sag or tie member to the purlin (rod, angle or channel) is provided, it shall not be considered in modelling the structure for analysis except its effect as lateral support to the purlin members in strength design.

14 Concrete Works

14.1 Construction of all RCC works shall be done with approved design mix as per IS 456 and the materials used viz. Cement, coarse & fine aggregate, Reinforcement steel etc. shall conform to relevant BIS standards.

14.2 The min. grade of concrete shall be M25 (M30 in coastal areas/marshy soil) for all RCC works except liquid retaining structures like underground water tank, septic tank, etc. where minimum grade of concrete shall be M30 (M35 in coastal areas/marshy soil).

14.3 Cement higher than 43 Grade shall not be used in construction.

14.4 Unless otherwise specified elsewhere, PCC shall be of min. grade M10 (nominal mix 1:3:6) except for mud mat, back filling of ground pockets or leveling course which shall be of grade M7.5 (nominal mix 1:4:8).

14.5 Reinforcement steel shall be of high strength TMT bars of grade Fe500 D conforming to IS: 1786.

14.6 Unless specified otherwise for grouting works anti shrink ready mix grout of approved make or cement mortar (CM) grout with non-shrink compound shall be used. The grout shall be high strength grout having min. characteristic strength of 35 N/mm² at 28 days.



Bharat Coking Coal Limited

Tender for Design, Engineering, Procurement & Supply, Construction & Erection, Testing, Commissioning, Associated Transmission System and Comprehensive O&M for 5 (Five) Years of 20 MW (AC)/28 MWp (DC) Solar PV Power Plant and connecting Transmission lines at Dugdha Washery, BCCL- Dhanbad



CNUL

15 Miscellaneous Steel Works

- 15.1** Unless otherwise specified elsewhere, all structural steel work shall be designed as per provisions of IS: 800 with working stress method of design (WSD) or limit state method of design (LSM).
- 15.2** Structural steel hot rolled sections, flats and plates shall conform IS: 2062, structural Pipes shall be medium (M)/ high (H) grade conforming to IS: 1161, chequered plate shall conform to IS: 3502 and Hollow steel sections for structural purposes shall conform to IS: 4923.

16 Buildings and Plinth for Open Installations

16.1 General Requirement

- 16.1.1** Plant buildings and plinth for open installations are required to be constructed for housing the electrical equipment/ panel (Local Control Room Building - LCR) and Control room cum office cum store (Main Control Room Building - MCR) for operation and maintenance of Photovoltaic Solar Power Plant. Security room at main gate & Security cabin(s) (at strategic locations) shall also be provided to secure the plant from any theft/ burglary/unauthorized entry.
- 16.1.2** Unless otherwise specified elsewhere, all buildings and plinth for open installations except Security room/ cabin shall have RCC framed structure. Masonry partition walls shall be provided for Kitchen, Pantry, Battery room and Toilet units. For other rooms AL Glass partitions shall be provided. The plinth for open installations and equipment area shall be designed with OEM requirements. The security room/ cabin(s) shall be of prefabricated structure.
- 16.1.3** All buildings shall have provision of adequate windows for natural light & ventilation, fire safety provisions and shall be designed as per provisions of National building code (NBC).
- 16.1.4** The contractor shall submit the proposed equipment layout drawings to the Engineer for approval before development of Architectural drawings. The building layout, exterior elevations shall be aesthetically designed following good architectural practices to get a

20 MW (AC) Solar PV Power Plant at Dugdha, BCCL- Dhanbad, Jharkhand	<u>Tender No.</u>	125 Page
--	--	-------------------



Bharat Coking Coal Limited

Tender for Design, Engineering, Procurement & Supply, Construction & Erection, Testing, Commissioning, Associated Transmission System and Comprehensive O&M for 5 (Five) Years of 20 MW (AC)/28 MWp (DC) Solar PV Power Plant and connecting Transmission lines at Dugdha Washery, BCCL- Dhanbad



CNUL

pleasant look. Horizontal/ vertical bands through projections/ groves in external plaster may be provided to break the monotony. Roof slab shall have projection of 450mm beyond external walls with RCC parapet wall of 450 mm clear height all-around which shall form a projected band at roof level. For weather protection all doors and windows shall be provided with 450mm wide RCC chajja. However, chajja for rolling shutter shall be 750mm wide.

16.2 Functional requirements

16.2.1 MCR Building

For operation & maintenance of SPV Plant, unless otherwise specified elsewhere, Control room cum office area of MCR building shall provide following facilities.

- Air-conditioned area (with provision of split A/C unit of adequate capacity) for SCADA room (min. carpet area 12m²), Conference room (min. carpet area 20 m²) & Supervisor cabin and office area (min. carpet area 20 m²)
- Inverter/ Switchgear, equipment room(s) as per OEM requirements
- Store cum record room (min. carpet area 15 m²)
- Battery room as per requirement
- Toilet block with separate gents and ladies wash room facilities (min. total carpetarea 12 m²)
- Pantry with service platform and utensil washing facilities (min. carpet area 5 m²)
- Suitable provision for passage (for smooth movement of O & M personnel), cable trenches, operating area etc. (min. clear width 1500mm)

16.2.2 LCR/ ICR

- Inverter and associated equipment shall be installed on plinth as open installations. They shall generally comprise of data loggers, battery, inverter, electrical panels, etc. as per requirements and as per approved system drawings.
- There shall be suitable provision for easy/smooth passage of O&M personnel, cable trench, operating area, etc.
- The plinth supporting the ICR/LCR equipment shall have RCC framed structurewith foundations, columns and beams up to plinth level (FFL).
- The size and clear head room (below soffit of beam) for LCR/ICR shall be provided as per system/O&M requirements.
- In case of indoor installation of inverters, MCR and LCR/ICR building shall not be



Bharat Coking Coal Limited

Tender for Design, Engineering, Procurement & Supply, Construction & Erection, Testing, Commissioning, Associated Transmission System and Comprehensive O&M for 5 (Five) Years of 20 MW (AC)/28 MWp (DC) Solar PV Power Plant and connecting Transmission lines at Dugdha Washery, BCCL- Dhanbad



CNUL

clubbed together unless specified otherwise.

- However, when LCR/ICR and MCR building facilities are clubbed in one single building, the Equipment area (inverter room) and Office cum Control room area shall be separated by a brick wall with provision of internal entry door.
- MCR building shall have separate main entry to office area plus a provision of fire exit door.
- The size of inverter/HT panel room shall be provided as per system requirements.

16.2.3 Security Room/ Cabin

16.2.3.1 Contractor shall provide required number of pre-fabricated security cabins at strategic locations & at corners of the plot and 1 nos. security room at Main entry gate.

16.2.3.2 The Security room shall be of min. size 3m x 3m x 2.75m height. The Security cabin shall be of min. size 1.2 x 1.8m x 2.5m height.

16.2.3.3 Security room/ cabin shall be a pre-engineered & pre-fabricated structure. The walls and roof of the building shall be fabricated with double skin insulated sandwiched Al-Zn alloy coated high tensile steel metal panels (BMT- 0.5mm, Al-Zn alloy coating -150 GSM total on both sides). The insulation shall be of PUF with min. density 40kg/ cum and adequate thickness. Roof shall be provided with suitable slope, not less than 10° to the horizontal (approx. 1V:6H) for proper drainage of rain water and shall project 300mm beyond the walls. The make and (color) shade of pre-coated metal panels shall be subject to approval by the Engineer. Min. thickness of color coating shall be 20 micron (DFT) excluding prime coat 5 micron (DFT). The coating system shall confirm to IS: 15965.

16.2.3.4 The Main security room shall be provided with one Aluminum (AL) glazed door (0.75m wide x 2.1m height) on one face and AL glazed sliding windows (1.2m width x 1.0 m height) with AL grill on remaining three sides. Security cabin shall have one AL glazed door (0.75m wide x 2.1m height) and 1 no. AL sliding window (0.8m width x 1.0 m height) with AL (anodized) grill on one side. All glazing shall be of clear float glass with thickness of 4mm for window and 6 mm for door panel.

16.2.3.5 The door and windows shall be provided with all necessary fitting and fixtures like handles, tower bolts, mortise lock for door, stays, door stopper etc. All AL sections for doors and windows shall be anodized (min. average thickness 25 microns) or polyester powder coated (min. DFT 50 microns) with approved color shade for protection against weather.



Bharat Coking Coal Limited

Tender for Design, Engineering, Procurement & Supply, Construction & Erection, Testing, Commissioning, Associated Transmission System and Comprehensive O&M for 5 (Five) Years of 20 MW (AC)/28 MWp (DC) Solar PV Power Plant and connecting Transmission lines at Dugdha Washery, BCCL- Dhanbad



CNUL

- 16.2.3.6** Specially coated/ SS self-drilling screws/ fasteners conforming to class 3 as per ASTM: 3566.1 and 3566.2 shall only be used for all connections.
- 16.2.3.7** Anchor/ foundation bolts shall conform to IS: 5624 and IS 800.
- 16.2.3.8** The Security Cabin may be installed on concrete M20 skid platform (min. 250 mm thick, over 250 mm thick compacted rubble soling with interstices filled with sand). The top of skid shall be 200 mm above FGL. The concrete skid shall be provided with shrinkage reinforcement (8 dia @ 200 c/c both ways) near top surface. The concrete skid shall project 200mm beyond the walls.
- 16.2.3.9** The Security Room shall be supported on RCC framed structure with foundations, columns and plinth beams with 450 high plinth above FGL.
- 16.2.4** Portable Cabin
 - 16.2.4.1** Portable cabin shall be of size 15 x 10 x 8.6 feet (clear dimensions i.e. available volume) for MCR and Store Room. For other buildings, appropriate sizes as per available space and design may be proposed.
 - 16.2.4.2** The main fabrication of the structural frame work shall be integral and all welded (CO2 welding) type to comprise of the bottom, top, side & overall frame work. Self-draining roof and desired door-window with Insulation & electrical fittings inside thecabin. The structure should be durable, fire proof, light, sturdy, termite and water proof.
 - 16.2.4.3** The Portable cabin for MCR shall have provision for partition walls for a SupervisorRoom and seating area for 4 O&M personnel.
 - 16.2.4.4** Detailed Specifications

Component	Description	Reference Standard
Bottom/base frame	100 mm specially formed channel	IS 2062 for MS or IS 808 for Rolled section
Top frame	75 x 75 sq. mm pipes/tubes	IS 4923 (tube) IS 1239 (pipe)
Stiffeners Bottom	100 x 50 mm specially formed channels	IS 2062 or IS 808
Stiffeners Top	45 x 45 x 5 mm & 45 x 45 x 5 mm M.S Tee	IS 2062 or IS 808
Side Post	Specially formed 3.15 mm M.S post section	IS 2062



Bharat Coking Coal Limited

Tender for Design, Engineering, Procurement & Supply, Construction & Erection, Testing, Commissioning, Associated Transmission System and Comprehensive O&M for 5 (Five) Years of 20 MW (AC)/28 MWp (DC) Solar PV Power Plant and connecting Transmission lines at Dugdha Washery, BCCL- Dhanbad



Side wall stiffeners	Specially formed 2.00 mm M.S channels	IS 2062 or IS 808
Panelling outside	M.S Corrugated sheet (10 gauge)	IS 2062
Internal wall panelling	8 mm Pre-laminated sheet for wall	
Roof outside	M.S Plain sheet (18 gauge) with efficient drain of rain water and to avoid collection of dust leaves etc on the roof	IS 2062
False ceiling	5 mm 100% water proof sheet	-
Bottom flooring	10 mm MS Chequered Plate	IS 2062
M.S door	50 mm insulated M.S Door of size- 3' x 6'6" with hydraulic door closer, locks, handles. Door shall be fixed with heavy gauge MS hinges Weather shed for door.	IS 2062 For Hinge – IS 1341/1992 For Hydraulic Door Closer – IS 3564/96 Type-2
Insulation	1. At four side walls by 50 mm Glass wool insulation covered with 8 mm pre-laminated sheet 2. At ceiling by 100 mm Glass wool insulation covered with 5mm pre-laminated sheet (100% water proof) (All the Glass wool density-24)	Glass wool; IS 8183/93

16.2.4.5 Accessories

Wiring	Concealed wiring – PVC conduits using fire resistance wires
--------	---



Bharat Coking Coal Limited

Tender for Design, Engineering, Procurement & Supply, Construction & Erection, Testing, Commissioning, Associated Transmission System and Comprehensive O&M for 5 (Five) Years of 20 MW (AC)/28 MWp (DC) Solar PV Power Plant and connecting Transmission lines at Dugdha Washery, BCCL- Dhanbad



CNUL

Electrical Fitting/cabin	<ol style="list-style-type: none"> 1. Tube lights – 02 nos. 2. Door lights – 01 no. 3. Fans – 01 no. 4. Switches & sockets: 6 amps – 01 no. & 16 amps – 01no.
Furniture (for MCR)	Office Chairs with swivel mechanism, wheels and adjustable height - 6 Nos., 4 seater Round Discussion Table – 1 No., Supervisor Desk Table with Drawers for Supervisor – 1 No.,
Painting	Phosphating the cabin internally and painting with coat of epoxy primer (anti corrosive paint) & two coat of epoxy texture paint (corrosion resistant paint) of reputed make. The external surface of the cabin shall be painted with two coats of epoxy texture paint (corrosion resistant paint) of reputed make. The roof of the cabin painted with polyurethane paint.
M.S Racks with shutter OR Storage Cup board	M.S Storage Cupboard - 06 nos. Each Cup board made of M.S with full height door of size-4’ 10” (width)x 2’6” (depth) x 6’ (ht) comprising with 02 partitions at 2 ft height
Dummy plate	Size- 3’5” x 3’5”

16.2.4.6 The portable cabin for MCR shall be provided with adequate number of split type air conditioning units and fans.

16.2.5 Pre-Engineered Building (PEB)

16.2.5.1 General:

The PEB shall be made of structural steel construction with double skinned metal roofing and wall cladding of appropriate profile. PEB shall be complete with painting, metal fascia, metal gutter, rain water down comers, sun-shades, openings, etc., along with associated structural steel, cladding and roofing work insulation, Trims & Flashings. Each item of PEB like panels, masonry, plastering, flooring, foundation, fittings etc. shall be suitable for complete life of solar plant. The construction methodology for PEB shall also be submitted to the Employer/Owner for approval before start of works.

16.2.5.2 Structure and material specification

Component	Description	Reference Standard
-----------	-------------	--------------------



Bharat Coking Coal Limited

Tender for Design, Engineering, Procurement & Supply, Construction & Erection, Testing, Commissioning, Associated Transmission System and Comprehensive O&M for 5 (Five) Years of 20 MW (AC)/28 MWp (DC) Solar PV Power Plant and connecting Transmission lines at Dugdha Washery, BCCL- Dhanbad



Primary Structural Members: including the transverse rigid frames, columns, corner columns, end wall wind columns, beams, truss member, base pate.	Steel frame members with minimum thickness 4 mm with minimum yield strength of 345 MPa	IS2062 min Grade E250 Quality BR/ ASTM A572-12 Grade 50
Secondary Members: including the purlins,	Minimum thickness 3.15 mm. Secondary members for purlins and Girts shall have minimum yield strength of 345 MPa. Miscellaneous secondary	IS 811 or ASTM A1003-12 steel sheets conforming to



Bharat Coking Coal Limited

Tender for Design, Engineering, Procurement & Supply, Construction & Erection, Testing, Commissioning, Associated Transmission System and Comprehensive O&M for 5 (Five) Years of 20 MW (AC)/28 MWp (DC) Solar PV Power Plant and connecting Transmission lines at Dugdha Washery, BCCL- Dhanbad



CNUL

Girts, eave struts, bracing, flange bracing, base angles, clips, flashings and other miscellaneous structural parts. Suitable wind bracings sag rods to be reckoned while designing the structure.	members shall have minimum yield strength of 250 MPa.	ASTM A1011-12b Grade 50
Wall Cladding	Insulated wall cladding or roofing shall consist of double skin metal cladding with Poly Urethane Foam (PUF). PUF must be made of continuous method PU foam and must be CFC free, self-extinguishing, fire retardant type with density 40 +/-2 kg/m ³ and thermal conductivity 0.019-2.2 W/(m.K) at 10°C. The PUF panels shall be a factory made item ready for installation at site.	
Design Parameters and Design Loads		
Dead Load	Self-Weight of Structure including Purlins, Sheeting, Girts, Bracings, weight of turbo ventilators to be added as Dead load etc. Imposed Load (Live Loads) Live loads shall be as per IS – 875. For sloped roofs up to 10 deg. it shall be 0.75 kN/m ² .	
Wind Load	Design wind speed factors shall be as per IS: 875-III, however the minimum value of these factors shall be considered as K1 = 1.0, K2 = 1.0 & K3 = 1.0 for the design of PEB.	



Bharat Coking Coal Limited

Tender for Design, Engineering, Procurement & Supply, Construction & Erection, Testing, Commissioning, Associated Transmission System and Comprehensive O&M for 5 (Five) Years of 20 MW (AC)/28 MWp (DC) Solar PV Power Plant and connecting Transmission lines at Dugdha Washery, BCCL- Dhanbad



Earthquake Load	<p>All PEB structures shall be designed for Seismic forces. Vertical Deflection and Horizontal Sway Limits: a) Limiting Deflection: The limiting permissible vertical deflection for structural steel members shall be as per IS 800 2007.</p>	
------------------------	--	--

	b) The limiting permissible horizontal deflection for as per IS 800 2007 code where 'h' is height of building at eaves.	
--	---	--

Paint and Coating	<p>Steel shall be colour coated with total coating thickness of 25 microns (nominal) dry film thickness (DFT) comprising of silicon modified polyester (SMP with silicon content of 30% to 50 %) paint or Super Durable Polyester (XRW) paint of 20 microns (nominal) on one side (exposed face) on 5 micron (nominal) primer coat and 10 microns (nominal) SMP or Super Durable Polyester paint over 5 micron (nominal) primer coat on other side. SMP and polyester paints system shall conform to Product type 4 as per AS/ANZ 2728. The structural steel shall be hot-dipped galvanized, conform to IS: 4759 or relevant Indian standard</p>	
--------------------------	--	--

Plinth Protection	<p>750mm wide plinth protection minimum 75 mm thick of cement concrete 1:3:6 (1 cement : 3 coarse sand : 6 graded stone aggregate 20 mm nominal size) over 75 mm bed of dry brick ballast 40 mm nominal size well rammed and consolidated and grouted with fine sand including finishing the top smooth, shall be provided around the Pre-Engineered Building.</p>	
--------------------------	--	--

Rolling shutter	<p>Rolling shutter (Hand operated) shall be fabricated from 18 gauge steel and machine rolled with 75 mm rolling centres with effective bridge depth of 12 mm lath sections, interlocked with each other and ends locked with malleable cast iron clips to IS:2108 and shall be designed to withstand a wind load without excessive deflection. Metal rolling shutters and rolling grills as IS: 6248.</p>	
------------------------	--	--

Windows Frame	<p>Aluminium black powder coated section, frame shall be of 92x31 mm, minimum 16G thick as per approved design. Tinted glass and aluminium grill shall be provided.</p>	
----------------------	---	--



Bharat Coking Coal Limited

Tender for Design, Engineering, Procurement & Supply, Construction & Erection, Testing, Commissioning, Associated Transmission System and Comprehensive O&M for 5 (Five) Years of 20 MW (AC)/28 MWp (DC) Solar PV Power Plant and connecting Transmission lines at Dugdha Washery, BCCL- Dhanbad



CNUL

Roof Insulation and type	Both metal sheets shall have an under insulation of minimum 70 mm thick PUF with density 40 +/- kg/m3 and thermal conductivity 0.019-2.2 W/(m.K) at 10°C with guttersand down take pipes along with Flashing & Top cap of required size and colour complete with all necessary hardware. Roof shall be projected at-least 300 mm from the wall. Stiffening ribs / subtle fluting for effective water sheddingand special male / female ends with full return legs on sidelaps for purlin support and anticapillary flute in side lap shall be provided.
	Both upper and lower sheets shall be separated through spacers and fastened through zinc /zinc-tin coated self- drilling screws. The fastener size shall be calculated as per the design or manufacturers recommendations. Contractor may also alternatively make the PEB roofing with composite slab (RCC slab with permanent formwork). The composite slab scheme, design and drawings shall besubject to approval from Employer/Owner before start of work.
Wall Insulation	All voids of external and internal metalled walls shall have an under insulation of minimum 60 mm thick PUF with density 40 +/- kg/m3 and thermal conductivity 0.019-2.2 W/(m.K) at 10°C with proper supports etc. as approved. Both the walls should be separated by spacers system made up of cold formed steel bars and fastened through zinc /zinc-tin coated self-drilling screws.

16.3 The Design and drawings shall be submitted for approval prior to fabrication and installation.

17 Flooring, Skirting and Dado

17.1 Store area, Equipment Area

40 mm thick Cement concrete (IPS) flooring (1:2:4), aggregate size 10 mm down, conforming to IS 2571 with 2mm thick Heavy-duty epoxy coating (Industrial grade) of approved make on top as per manufacturer specifications and 10mm thick matching skirting of 100mm height.

17.2 SCADA Room, Control cum Office Room, Supervisor Room and Lobby

1200 mm X 1200 mm thick Heavy duty vitrified tile (8mm thick or more) flooring with

20 MW (AC) Solar PV Power Plant at Dugdha, BCCL- Dhanbad, Jharkhand	<u>Tender No.</u> <u>.....</u>	134 Page
--	--	-------------------



Bharat Coking Coal Limited

Tender for Design, Engineering, Procurement & Supply, Construction & Erection, Testing, Commissioning, Associated Transmission System and Comprehensive O&M for 5 (Five) Years of 20 MW (AC)/28 MWp (DC) Solar PV Power Plant and connecting Transmission lines at Dugdha Washery, BCCL- Dhanbad



matching skirting of 100mm height.

17.3 Battery Area/Room

Acid/ Alkali resistant tile flooring and 2100 height dado, Floor and dado tiles - 20mm and 12 mm thick respectively. However, in case of maintenance free batteries, vitrified tile (8mm thick) flooring and dado shall be provided.

17.4 Toilet

- 40 mm thick Ceramic tile (8mm thick) flooring and glazed tile (6mm thick) 2100 height dado.
- 20mm thick Granite stone finish over platform for wash basin.

17.5 Pantry

40 mm thick heavy duty vitrified tile (8 mm thick) flooring and glazed tile (6mm thick) 2100 mm height dado, 20mm thick Granite stone finish over service platform.

17.6 Passage/ Corridor

40 mm thick Heavy duty vitrified tile (8mm thick) flooring with matching skirting of 100mm height.

17.7 Steps

Kota stone (20 thick) or 50 thick cement concrete (IPS) flooring conforming to IS 2571.

17.8 All items shall be of reputed make. Only Items with approved samples by the Engineer shall be used.

18 Doors and Windows

18.1 Doors, windows, louvers and ventilators shall be made of AL sections (minimum average thickness for windows and ventilators- 2.0mm, for partitions and doors- 2.5 mm), industrial grade, anodized (grade AC25, min. thickness 25 micron conforming to IS: 1868) or with polyester powder coating (Total DFT 50 microns conforming to IS: 13871) and shall be of approved make & colour shade. All sections, fittings and fixtures shall be anodized (min. thickness of coating 20 micron). The window and door shutters shall be of clear float/ wired/ ground glass as per design/ functional requirements. The doors in toilet area shall be of steel frame with solid core (MDF) flush shutter, 35mm thick, with laminated finish on both sides conforming to IS: 2202.



Bharat Coking Coal Limited

Tender for Design, Engineering, Procurement & Supply, Construction & Erection, Testing, Commissioning, Associated Transmission System and Comprehensive O&M for 5 (Five) Years of 20 MW (AC)/28 MWp (DC) Solar PV Power Plant and connecting Transmission lines at Dugdha Washery, BCCL- Dhanbad



- 18.2** AL Louvers, duct/ ventilation openings shall be provided as per functional requirement.
- 18.3** All doors, windows and ventilators shall be provided with all necessary fittings and fixtures like handles, tower bolts, wind stays, hinges etc. of heavy duty anodized AL. All doors shall be provided with hydraulic door closure of required capacity.
- 18.4** All windows shall be provided with suitable AL grill of anodized sections with adequate thickness for security purposes.
- 18.5** Clear float glass for window and door shutter shall be of min 4mm and 6mm thickness respectively. Wired/ ground glass where provided shall be of min thickness 6mm.
- 18.6** Entrance door and door in passage shall be min. 1.5m wide (double leaf) x 2.1 m height while door for Conference room and Store room shall be min. 1.2m wide x 2.1m height. All other doors shall be min. 1.0m wide x 2.1m height except for WC which may be of 0.8m width.
- 18.7** Rolling shutters shall be of required size and shall be made of cold rolled steel strips with adequate gauge thickness (min. 18 gauge) and shall conform to IS 6248. Rolling shutter shall be provided with all fixture, accessories, paintings etc. all complete and shall be mechanically operated type.

19 Roofing

- 19.1** The roof of all buildings shall be provided with min. slope of 1:100 for effective drainage of rain water. The slope shall be achieved either by application of screed concrete of grade 1:2:4 (with 12.5mm down coarse aggregate) with min. 25mm thick CM 1:4 layer on top to achieve smooth surface to facilitate application of water proofing treatment.
- 19.2** The water proofing treatment shall be in situ five course water proofing treatment with APP (Atactic Polypropylene) modified Polymeric membrane over roof consisting of first coat of bitumen primer @ 0.40Kg per sqm, 2nd & 4th courses of bonding material @ 1.20 kg/sqm, which shall consist of blown type bitumen of grade 85/25 conforming to IS : 702, 3rd layer of roofing membrane APP modified Polymeric membrane 2.0 mm thick of 3.00 Kg/sqm weight consisting of five layers prefabricated with centre core as 100 micron HMHDPE film sandwiched on both sides with polymeric mix and the polymeric mix is protected on both sides with 20 micron HMHDPE film. The top most layer (5th layer) shall be finished with brick tiles of class designation 10 grouted with cement mortar 1:3 (1 cement: 3 fine sand) mixed with 2% integral water proofing compound by weight of cement over a 12 mm layer of cement mortar 1:3 (1 cement: 3 fine sand) and finished neat. The water

20 MW (AC) Solar PV Power Plant at Dugdha, BCCL- Dhanbad, Jharkhand

Tender No.
.....



Bharat Coking Coal Limited

Tender for Design, Engineering, Procurement & Supply, Construction & Erection, Testing, Commissioning, Associated Transmission System and Comprehensive O&M for 5 (Five) Years of 20 MW (AC)/28 MWp (DC) Solar PV Power Plant and connecting Transmission lines at Dugdha Washery, BCCL- Dhanbad



CNUL

proofing treatment shall be extended over golla/fillet and inner face of the parapet up to 450mm height.

19.3 The corners at parapet wall and slab shall be provided with 50 thick fillet/ golla in CM 1:3 with neat finish.

19.4 Required no. of rain water down take pipes min. 100mm dia. PVC pipes (UV resistant),with 450x450mmx15mm deep khurra and MS grill at inlet shall be provided for rain water disposal.

20 Plinth protection and drain

20.1 750mm wide plinth protection with min. 75mm thickness of PCC (1:3:6) over 75 mm thick bed of dry brick ballast, 40mm nominal size well rammed and consolidated and grouted with fine sand, shall be provided around all the buildings.

20.2 A peripheral drain (except for Security room/ cabin) of min. internal size 250mm x 250mm with brick walls in CM 1:6 over 75mm thick PCC (1:3:6) bedding with 12mm thick plaster in CM 1:5 and 25thk PCC (1:3:6) coping at top shall be provided along theperiphery of the plinth protection for collection and disposal of rain water from buildingroof.

21 Plinth filling for buildings

Plinth beam, when provided, shall be taken minimum 200mm below FGL. The plinth filling below Ground floor (GF) for all buildings shall be provided with followingspecifications.

- (i) Well compacted sub-grade
- (ii) Well compacted boulder soling with interstices filled with sand over compactedsub-grade.
- (iii) 75mm thick PCC 1:3:6 over (ii) (iv)
100mm thick PCC 1:2:4 over (iii)
- (v) 40mm thick floor finish over (iv)

22 Anti- termite Treatment

In case of presence of termites at the project site, an anti-termite treatment shall be provided for all foundation pits and building plinth in MCR building conforming to IS: 6313 to control entry of termites



Bharat Coking Coal Limited

Tender for Design, Engineering, Procurement & Supply, Construction & Erection, Testing, Commissioning, Associated Transmission System and Comprehensive O&M for 5 (Five) Years of 20 MW (AC)/28 MWp (DC) Solar PV Power Plant and connecting Transmission lines at Dugdha Washery, BCCL- Dhanbad



23 Plumbing & Sanitary Works

23.1 Toilet block shall have following min. fittings:

- Wall mounted WC (Western type) 390 mm high with toilet paper roll holder, low height flushing tank and all fittings
- A set of 2 wall mounted Urinals (430 x 260 x 350 mm size) with flushing tank and all fittings (Gent’s wash room only)
- Wash basin (550 x 400 mm) over concrete platform with all fittings including 2-pillar cocks
- Wall mirror (600 x 450 x 6 mm thick clear float glass) with hard board backing
- CP brass towel rail (600 x 20 mm) with C.P. brass brackets – one each in common area and bathroom (bathroom if applicable)
- Soap holder and liquid soap dispenser one each in common area and bathroom (bathroom if applicable)
- Shower and mixer for hot and cold water in bathroom (if applicable)
- Ventilators – Mechanical exhaust facility of adequate capacity
- Overhead PVC water storage tank – Capacity 1000 litres (common for both washrooms) (2000 litres in case bathroom is to be provided)

23.2 Pantry room shall be provided with kitchen sink cum drain board and provision for installation of Water Cooler.

23.3 One toilet room with provision of WC and Wash basin shall be provided at Security Room near main gate.

23.4 Necessary plumbing lines for MCR building and Security Room near main gate.

23.5 All sanitary ware, fittings and fixtures shall be of reputed Make and Type and approved by the Engineer. All fittings, fastener, grating shall be of CP brass conforming to relevant BIS standards.

24 Painting & Other Finishes

Painting and white wash/ colour wash for the buildings shall conform to relevant BIS standards.

The make and colour shade of the finish shall be as advised and approved by the Engineer.

20 MW (AC) Solar PV Power Plant at Dugdha, BCCL- Dhanbad, Jharkhand	<u>Tender No.</u> <u>.....</u>	138 Page
--	--	-------------------



Bharat Coking Coal Limited

Tender for Design, Engineering, Procurement & Supply, Construction & Erection, Testing, Commissioning, Associated Transmission System and Comprehensive O&M for 5 (Five) Years of 20 MW (AC)/28 MWp (DC) Solar PV Power Plant and connecting Transmission lines at Dugdha Washery, BCCL- Dhanbad



Internal Walls except toilets & battery room	Acrylic emulsion (for MCR) & Oil bound distemper (for LCR/ Security Room)
Battery room	Acid/ Alkali resistant tiled dado of 2100 mm height & Acid resistant resin-based epoxy paint above dado (Vitrified tile flooring and dado with oil bound distemper in case of maintenance free batteries)
Toilet	Oil bound distemper
External Walls	All weather proof cement based acrylic emulsion paint, exterior grade
MMS foundations/ Earth pit Enclosure	Cement paint
Underside of roof slab	White wash
Air-conditioned areas	Underside of roof slab- Under deck insulation with 50mm thick mineral wool, min. density 45 kg/ m ³ and Gypsum board false ceiling with GI grid/ Gypsum tile (600x600 mm x 12 thick) false ceiling with AL grid as per manufacturer's details
Structural steel work	2 coats of synthetic enamel paint over 2 coats of suitable primer

25 Air conditioning & Ventilation for MCR and Other Buildings

- 25.1** All buildings shall be equipped with appropriate numbers of fans for effective heat dissipation.
- 25.2** In MCR building, the supervisor room, Conference room and SCADA room shall have split type air conditioning units.

26 Fire Extinguishers

- 26.1** All buildings shall be installed with required no. of fire extinguishers as per relevant BIS standard and NBC. Liquefied CO₂/ foam/ ABC type fire extinguisher shall be upright type of capacity 10kg conforming to IS: 2171, IS: 10658.
- 26.2** The fire extinguisher shall be suitable for fighting fire of Oils, Solvents, Gases, Paints, Varnishes, Electrical Wiring, Live Machinery Fires, and all Flammable Liquid & Gas.

27 Sand buckets

- 27.1** Sand buckets shall be wall mounted made from at least 24SWG sheet with bracket fixing on wall conforming to IS: 2546.



Bharat Coking Coal Limited

Tender for Design, Engineering, Procurement & Supply, Construction & Erection, Testing, Commissioning, Associated Transmission System and Comprehensive O&M for 5 (Five) Years of 20 MW (AC)/28 MWp (DC) Solar PV Power Plant and connecting Transmission lines at Dugdha Washery, BCCL- Dhanbad



CNUL

27.2 All buildings shall be provided with required no. of sand buckets as per relevant BIS standard and NBC. 4 No. of Bucket stands with four buckets on each stand shall be provided in the Transformer Yard.

28 Sign Boards and Danger Boards

28.1 The sign board containing brief description of major components of the power plant as well as the complete power plant in general shall be installed at appropriate locations of the power plant as approved by Engineer

28.2 The Signboard shall be made of steel plate of not less than 3 mm. Letters on the board shall be with appropriate illumination arrangements.

28.3 Safety signs, building evacuation plan and direction signs, assembly points shall also be placed at strategic locations.

28.4 The Contractor shall provide to the Engineer, detailed specifications of the sign boards.

29 Masonry Work

29.1 The masonry work shall be of bricks, laterite blocks (as per site conditions) or concrete blocks.

29.2 All external walls of buildings shall be 230mm and internal walls shall be 230mm or 115mm as per requirements.

29.3 All concrete block masonry walls shall be min. 200mm thick.

29.4 Brick work shall be in cement mortar (CM) 1:6 & 1:4 for 230 mm and 115 mm thick brick wall respectively unless specified.

29.5 Unless otherwise specified elsewhere, Bricks shall be of class designation 7.5 conforming to IS: 1077, IS: 2212 & IS: 3495.

29.6 All concrete blocks shall be of min. compressive strength of 7.5 N/mm² and shall be of Grade-A conforming to IS: 2185.

29.7 The laterite blocks shall conform to IS: 3620.

29.8 All buildings shall be provided with suitable damp-proof course (DPC). The DPC shall be with PCC (1:2:4) using 6 down coarse aggregate and water proofing admixture. The min. thickness of DPC shall be 40mm.

29.9 The construction of brick masonry shall conform to IS: 2212. Construction of Concrete block masonry shall conform to IS: 2572.



Bharat Coking Coal Limited

Tender for Design, Engineering, Procurement & Supply, Construction & Erection, Testing, Commissioning, Associated Transmission System and Comprehensive O&M for 5 (Five) Years of 20 MW (AC)/28 MWp (DC) Solar PV Power Plant and connecting Transmission lines at Dugdha Washery, BCCL- Dhanbad



30 Plastering, Pointing & Coping Works

- 30.1 All brick masonry work shall be provided with plaster.
- 30.2 Wall and ceiling plaster shall be in cement mortar (CM) 1:6 and 1:3 respectively.
- 30.3 Thickness of plaster shall be 18mm and 12mm respectively for rough and smooth surface of the masonry wall. The ceiling plaster shall be 6mm thick.
- 30.4 All joints in stone masonry shall be raked and pointed in cement mortar (CM) 1:3 except specified otherwise.
- 30.5 Exposed top surface of brick or stone masonry shall be provided with 25 mm thick plain cement concrete (PCC) coping (1:2:4) with trawl finish. All exposed coping shall be provided with suitable slope and projection for easy drainage of water.
- 30.6 All door and window chajja shall be provided with 10mm wide drip course.

31 Building Water Supply & Plumbing Works

- 31.1 C-PVC pipes shall be used for all internal building water supply works while all external water supply pipes shall be uPVC conforming to relevant BIS standard.
- 31.2 Rain water pipe shall be of PVC conforming to relevant BIS standard.
- 31.3 All sewerage, waste water and ventilation pipes shall be of HDPE conforming to relevant BIS standard.
- 31.4 MCR building and Security room shall be connected to Sewage treatment facility including all associated works like Manholes etc.

32 Sewage Treatment facility

- 32.1 The Contractor shall design & provide soak pit and RCC Septic tank for treatment of sewage and waste water from MCR building and Security room. The septic shall be designed as liquid retaining structure conforming to IS:3370 for design loads as specified under Cl. No. 35. However, in case of ground water within 1.5m of finished grade level or the soil strata being of low permeability (permeability $\leq 10^{-6}$ m/s) where septic tank and soak pit arrangement is not effective, suitable packaged sewage treatment plant of reputed make/manufacture shall be provided. The sewage treatment facility shall be of required capacity and of proven design suitable for total of 15 people.
- 32.2 The design and drawings shall be submitted for approval prior to execution.



Bharat Coking Coal Limited

Tender for Design, Engineering, Procurement & Supply, Construction & Erection, Testing, Commissioning, Associated Transmission System and Comprehensive O&M for 5 (Five) Years of 20 MW (AC)/28 MWp (DC) Solar PV Power Plant and connecting Transmission lines at Dugdha Washery, BCCL- Dhanbad



CNUL

33 Pipe & Cable Trenches

- 33.1** All trenches inside the building and transformer area shall be of RCC. The min. wall and base slab thickness shall be 100mm for depth \leq 850mm and 150mm for depths $>$ 850mm.
- 33.2** The trench shall be designed for loads as specified under ‘Design Loads’. External trenches shall be kept min. 100mm above FGL to avoid entry of rain water. In case of straight length of the trench being more than 40m, suitable expansion joints with PVC water stop shall be provided.
- 33.3** Internal trenches (inside buildings) shall be provided with chequered plate (min. 8mm thick with stiffening angle ISA 50x50x6 @ 750 mm c/c for trench width greater than 800mm) covers while external trench shall have precast concrete covers.
- 33.4** Min. thickness of precast cover shall be 50mm. Both bearing edges of the cable trench and all edges of pre-cast concrete covers shall be provided with min. 50x50x6 mm edge protection angle with lugs.
- 33.5** The trench cover (chequered or pre – cast both) shall be provided with suitable lifting hooks.
- 33.6** As required suitable MS insert plates shall be provided on trench wall to support the cable rack/ pipe.
- 33.7** The trench bed shall have a slope of approx. 1(V):250(H) along and 1(V):50(H) across the length of the trench. The cable trench shall have a dewatering sump (s) of size 450x450x450 mm depth at suitable location to facilitate collection & pumping out of rainwater from the trench.
- 33.8** The external buried cables shall be laid in excavated trench as specified under specifications for Electrical works. The sand for filling shall be of Grade – IV conforming to IS: 383.

34 Transformer Yard Civil Works

- 34.1** Transformer and equipment foundations shall be founded on piles/isolated spread footings or block foundation depending on the final geotechnical investigation report and functional requirements.
- 34.2** In case of transformer oil tank capacity \geq 2000 litres, the transformer foundation shall have its own soak pit which would cover the area of the transformer and cooler banks, so as to collect any spillage of oil in case of emergency. The retention capacity of the soak pit shall be equal to volume of the transformer oil (excluding free space above gravel) and it shall be filled with granite stone gravel of size 40mm, uniformly graded, with 200 mm free space above gravel fill.



Bharat Coking Coal Limited

Tender for Design, Engineering, Procurement & Supply, Construction & Erection, Testing, Commissioning, Associated Transmission System and Comprehensive O&M for 5 (Five) Years of 20 MW (AC)/28 MWp (DC) Solar PV Power Plant and connecting Transmission lines at Dugdha Washery, BCCL- Dhanbad



- 34.3** In case of transformer oil tank capacity more ≥ 20000 litres, the soak pit shall be connected to a separate burnt oil pit through discharge pipe (300 mm dia) and shall be suitably sized to accommodate full oil volume (excluding free board above inlet pipe) of the transformer connected to it, without backflow. In this case the capacity of the soak pit may be reduced to min. 1/3rd of the total transformer oil volume. The burnt oil pit shall be further connected to oily water drainage system. The water shall be discharged into the nearest drain by gravity flow or pumping after suitable treatment as per statutory and code provisions.
- 34.4** Both, the transformer soak including side walls and the burnt oil pit shall be of RCC and shall be provided with sump (min. 500 mm x 500 mm x 400mm deep) and slope of 1:50 in concrete screed of 1:1 – 1/2:3 to the floor slab towards the sump pit. The oil collection pit shall be provided with 20mm dia. MS rung ladder with 2 coats of epoxy paint over 2 coats of primer, a manhole & removable RCC cover. The inside of oil collection pit shall be plastered with 6 mm thick CM 1:6 and painted with 2 coats of epoxy paint over 2 coats of primer.
- 34.5** The area around the transformer and equipment shall be covered with uniformly graded granite stone gravel of size 40mm.
- 34.6** The area shall be provided with galvanized chain link fence of height min 1.8m with 3.5m wide gate. The specifications for fencing shall be similar to those specified under Cl. No. 31.3 except fence post which shall be of MS angle (ISA 65x65x6) spaced at 2.5m c/c.
- 34.7** The Gate of size 3.5m shall be of MS pipe (medium class conforming to IS: 1161) frame with hard drawn steel wire fabric mesh (50x50mmx3mm thick conforming to IS: 1566) including all accessories and fittings. MS angle posts shall conform to IS 2062.
- 34.8** In addition to main gate a wicket gate of MS pipe (medium class conforming to IS: 1161) frame with 1.0 m width with hard drawn steel wire fabric (50x50x3mm thick conforming to IS: 1566) shall be provided for man entry for maintenance purpose.
- 34.9** The transformer yard fencing work shall conform to CEIG requirements.
- 34.10** The requirement of fire barrier wall between transformers shall be as per Electricity Rules and IS: 1646 recommendations. Minimum wall thickness shall be 230mm for RCC wall and 300mm for masonry wall.



Bharat Coking Coal Limited

Tender for Design, Engineering, Procurement & Supply, Construction & Erection, Testing, Commissioning, Associated Transmission System and Comprehensive O&M for 5 (Five) Years of 20 MW (AC)/28 MWp (DC) Solar PV Power Plant and connecting Transmission lines at Dugdha Washery, BCCL- Dhanbad



35 Potable Water Supply & PV Module Cleaning System

- 35.1** The contractor shall design and install the effective module cleaning system.
- 35.2** A regular supply of suitable quantity of water shall be ensured by the contractor to cater day-to-day requirement of drinking water and for cleaning of PV modules during entire O&M period. The Contractor is advised to ascertain the availability of good quality ground water at site for construction, drinking and module cleaning purpose. In case of non-availability of ground water source, the contractor shall explore the option of supply of water through water tankers. In case the water quality is not suitable for drinking or module cleaning purpose, the Contractor shall install suitable water treatment facilities.
- 35.3** The Contractor shall estimate the water requirements for cleaning the photovoltaic modules at least once in two weeks or at closer frequency as per the soiling conditions prevailing at site, in order to operate the plant at its guaranteed plant performance. Also, the contractor is required to plan the water storage accordingly with provision of a tank of suitable capacity for this purpose. However, min. consumption of 2 Ltr / Sqm of surface area of SPV module shall be considered in estimation of required quantity of water storage.
- 35.4** Water used for drinking & PV module cleaning purpose shall generally be of potable quality and fit for cleaning the modules with TDS generally not more than 75 PPM. In case of higher salt contents, the water shall be thoroughly squeezed off to prevent salt deposition over module surface. However, water with TDS more than 200 PPM shall not be used directly for module cleaning without suitable treatment to control the TDS within acceptable limits. The water must be free from any grit and any physical contaminants that could damage the panel surface.
- 35.5** If required, for settlement of any grit/ unacceptable suspended particles in the water a settling tank shall be installed before the inlet of the storage tank. Suitable arrangement for discharge/ disposal of sediment/ slush shall be provided in silting chamber by gravity disposal in surface drain or with provision of sludge sump and pump of adequate capacity.
- 35.6** The module cleaning system shall include construction of RCC tank or supply and installation of Ground mounted PVC tank (s) of required storage capacity, pumps (including 1 No. standby pump), water supply mains and flexible hose pipes, taps, valves (NRV, Butterfly valve, Ball valve, Gate valve, PRV, scour valve etc.), Water hammer arrester(s), pressure gauge, flow meter etc. as per the planning & design.
- 35.7** In case of over ground water storage tank, the contractor shall check its effect on plant performance through shadow analysis. The PVC storage tank shall conform to IS: 12701. The



Bharat Coking Coal Limited

Tender for Design, Engineering, Procurement & Supply, Construction & Erection, Testing, Commissioning, Associated Transmission System and Comprehensive O&M for 5 (Five) Years of 20 MW (AC)/28 MWp (DC) Solar PV Power Plant and connecting Transmission lines at Dugdha Washery, BCCL- Dhanbad



valves shall conform to IS: 778. A suitable metal sheet canopy for protection from direct sunlight shall be provided over the tank area.

- 35.8** The water supply mains could be either of GI, uPVC or HDPE, however, the vertical pipe connecting supply main to the discharge point shall be of GI.
- 35.9** Masonry chamber shall be provided for Main gate valve at pump end. Whereas, as per requirements, at other locations either a masonry or GI/ HDPE pipe chamber may be provided.
- 35.10** Module cleaning procedure and pressure requirement at discharge point shall be as per the recommendation of PV module manufacturer. However, discharge pressure atoutlet shall not be less than 5 kgf/cm²(0.5 MPa)
- 35.11** All the pipes thus laid shall be buried in ground at least 150mm below FGL or laid aboveground clamping on suitable concrete support blocks. In case of above ground piping only GI pipes shall be used.

36 Underground Water Tank

- 36.1** The top of the UG tank shall be 250 mm above FGL.
- 36.2** The tank shall have clear free board of 300mm above MWL.
- 36.3** The tank bottom shall have a slope of 1:100 towards drainage sump (500x500x500 mmdeep). The slope shall be provided either in structural slab or in screed concrete (1:2:4)trawl finished. 1000x1000 mm size Manhole in roof slab and 20 mm MS rung ladder shall be provided for easy access to the storage tank and silting chamber for periodic cleaning. The manhole shall be covered with RCC precast cover. 50x50x6 mm MS angle with lugs shall be provided around precast cover and tank slab opening for edgeprotection. Rungs shall be painted with 2 coats of epoxy paint over 2 coats of primer.
- 36.4** The underground RCC tank shall be designed for following load conditions:
 - External earth pressure + hydrostatic pressure due to ground water table (to be considered at FGL for design purposes) + Surcharge of 20 kN/ Sqm and Tank Empty.
 - Tank full up to MWL and no external loads
- 36.5** The design shall conform to IS: 3370 with maximum crack width of 0.1mm for wall, bottom slab and roof slab. Min. grade of concrete shall be M30 (M35 in coastal areas,marshy and saturated soils) conforming to IS: 456. Suitable construction joints shall beprovided as per provisions of IS: 3370 (Part 1). Water proofing admixture conforming to relevant BIS standard



Bharat Coking Coal Limited

Tender for Design, Engineering, Procurement & Supply, Construction & Erection, Testing, Commissioning, Associated Transmission System and Comprehensive O&M for 5 (Five) Years of 20 MW (AC)/28 MWp (DC) Solar PV Power Plant and connecting Transmission lines at Dugdha Washery, BCCL- Dhanbad



CNUL

and of approved make shall be added to concrete as per manufacturer’s recommendations.

36.6 The underground water tank shall be tested for water tightness as per the provisions of IS 3370 (Part-4). In case any leakage is noticed the same shall be repaired by injection of cement grout installing suitable nozzles around affected areas. Outside face of water tank in contact with water and soil and underside of roof slab shall be painted with 2 coats of epoxy paint.

37 Transmission Line Structures

37.1 Galvanized 220 kV and 132 kV Transmission Line towers, Tower extensions & accessories and 11 kV, 22kV, 22kV & 33 kV transmission poles, towers & accessories shall be designed following latest guidelines of respective transmission licensee / distribution licensee and get approved from them before execution. In absence of SEB/STU guidelines REC (Rural Electrification Corporation) standards may be followed. Support at corner with angle > 100 shall be provided with a 4-pole structure or a lattice tower structure. Use of PCC spun pole and RCC pole is not acceptable.

37.2 Approved copies of these designs & drawings shall be submitted to the employer for reference and record.

38 Miscellaneous structures

38.1 Support structure for weather monitoring device

38.1.1 Weather monitoring device shall be mounted on tubular steel pole of required height. The pole shall conform to IS: 2713.

38.1.2 The pole shall be secured to an independent RCC foundation structure through Baseplate and Anchor bolt assembly.

38.1.3 200 long 20 dia. rods shall be welded to the pole at 300 mm C/c for access to the device for maintenance purpose.

38.1.4 The support structure shall be hot dip galvanized.

38.2 Support structures for SMU

38.2.1 SMU shall not be supported from MMS and shall have an independent structural steel supporting frame of galvanized ISMC 75 with transverse diagonal bracings of ISA 65x65x6 to each column post.

38.2.2 Column post and bracings shall be supported with 300 mm (min.) diameter and 850mm (min.) deep below GL piles in cement concrete (nominal mix 1:1:2). The column post and bracings



Bharat Coking Coal Limited

Tender for Design, Engineering, Procurement & Supply, Construction & Erection, Testing, Commissioning, Associated Transmission System and Comprehensive O&M for 5 (Five) Years of 20 MW (AC)/28 MWp (DC) Solar PV Power Plant and connecting Transmission lines at Dugdha Washery, BCCL- Dhanbad



CNUL

shall be extended into the piles upto 800 mm with 50mm cover at the bottom.

- 38.2.3** The pile shall project 200 mm above GL.
- 38.2.4** The support structure shall hot-dip galvanized and of adequate height to ensure min. ground clearance of 800 mm to SMU unit.
- 38.3** LA Mast and Foundation
- 38.3.1** The LA mast shall be a self-supporting structure with GI tubular pole of required height. The pole shall conform to IS: 2713.
- 38.3.2** The pole shall be supported on RCC pedestal and foundation structure through baseplate & anchor bolt assembly.
- 38.3.3** 200 mm long, 20 dia rods shall be welded to the pole at 300 mm c/c for access to the device for maintenance purposes.
- 38.3.4** The support structure shall be hot-dip galvanized. Min depth of foundations shall be 1200 mm below GL.

D Quality Assurance and Inspection of Civil Works

1 Introduction

- 1.1** This part of the specification covers the sampling, testing and quality assurance requirement (including construction tolerances and acceptance criteria) for all civil and structural works covered in this specification.
- 1.2** This part of the technical specification shall be read in conjunction with other parts of the technical specifications, general technical requirements & erection conditions of the contract which covers common QA requirements. Wherever IS code or standards have been referred they shall be the latest revisions.
- 1.3** The rate for respective items of work or price shall include the cost for all works, activities, equipment, instrument, personnel, material etc. whatsoever associated to comply with sampling, testing and quality assurance requirement including construction tolerances and acceptance criteria and as specified in subsequent clauses of this part of the technical specifications.
- 1.4** The QA and QC activities in all respects as specified in the technical specifications/ drawings / data sheets / quality plans / contract documents shall be carried out at no extra cost.
- 1.5** The contractor shall prepare detailed construction and erection methodology scheme which shall



Bharat Coking Coal Limited

Tender for Design, Engineering, Procurement & Supply, Construction & Erection, Testing, Commissioning, Associated Transmission System and Comprehensive O&M for 5 (Five) Years of 20 MW (AC)/28 MWp (DC) Solar PV Power Plant and connecting Transmission lines at Dugdha Washery, BCCL- Dhanbad



be compatible to the requirements of the desired progress of work execution, quality measures, prior approvals from statutory authorities etc. if any and the same shall be got approved from the Engineer.

- 1.6** If required, work methodology may be revised/ reviewed at every stage of execution of work at site, to suit the site conditions, work progress commensurate with project schedule by the contractor at no extra cost to the Engineer

2 QA and QC Manpower

- 2.1** The contractor shall nominate one overall QA coordinator for the contract detailing the name, designation, contact details and address at the time of post bid discussions.
- 2.2** All correspondence related to Quality Assurance shall be addressed by the contractor's QA coordinator to the Engineer.
- 2.3** Employer/ Consultant shall address all correspondence related to Quality issues to the contractor's QA coordinator. The contractor's QA coordinator shall be responsible for coordination of Quality activities between various divisions of the contractor and their sub-vendors on one hand & with Engineer on the other hand.
- 2.4** The contractor shall appoint a dedicated, experienced and competent QA & QC in-charge at site, preferably directly reporting to the Project Manager, supported as necessary by experienced personnel, to ensure the effective implementation of the approved QAP.
- 2.5** The contractor shall finalize and submit a deployment schedule of QA & QC personnel along with their details to Engineer for approval/ acceptance and further shall ensure their availability well before the start of the concern activity.



Bharat Coking Coal Limited

Tender for Design, Engineering, Procurement & Supply, Construction & Erection, Testing, Commissioning, Associated Transmission System and Comprehensive O&M for 5 (Five) Years of 20 MW (AC)/28 MWp (DC) Solar PV Power Plant and connecting Transmission lines at Dugdha Washery, BCCL- Dhanbad



CNUL

3 Laboratory and Field Testing

- 3.1** The contractor shall make necessary provisions to provide all facilities required for QA& QC activities by setting up a field laboratory for QA and QC activities in line with the indicative field QA & QC laboratory set-up.
- 3.2** The Laboratory building shall be constructed and installed with adequate facilities to meet the requirement of envisaged test setup. Temperature and humidity controls shall be available wherever necessary during testing of samples.
- 3.3** The quality plan shall identify the testing equipment/ instrument, which the contractor shall deploy and equip the field quality laboratory for meeting the field quality plan requirements.
- 3.4** The contractor shall furnish a comprehensive list of testing equipment/ instrument required to meet the planned/scheduled tests for the execution of works for Engineer's acceptance/ approval.
- 3.5** The contractor shall mobilize the requisite laboratory equipment and QA & QC manpower at least 15 days prior to the planned test activity as per the schedule of tests.
- 3.6** In case contractor desires to hire the services of any established laboratory nearby for any field tests then he shall ensure that the subject laboratory is well equipped with all requisite testing facilities and qualified QA & QC staff and this shall not affect in anyway the work progress.
- 3.7** All equipment and instruments in the laboratory/ field shall be calibrated before the commencement of tests and then at regular intervals, as per the manufacturer's recommendation and as directed by the Engineer. The calibration certificates shall specify the fitness of the equipment and instruments within the limit of tolerance for use. Contractor shall arrange for calibration of equipment and instruments by an NABL / NPL accredited agency and the calibration report shall be submitted to Engineer.
- 3.8** The tests which cannot be carried out in the field laboratory shall be done at a laboratory of repute. This includes selected IITs, NCB, CSMRS, reputed government / autonomous laboratories / organizations, NITs and other reputed testing laboratories. The test samples for such test shall be jointly selected and sealed by the engineer and thereafter these shall be sent to the concerned laboratory through the covering letter signed by Engineer. Test report along with the recommendations shall be obtained from the laboratories without delay and submitted to Engineer.
- 3.9** Based on the schedule of work agreed with the Engineer and the approved FQP, the contractor shall prepare a schedule of tests and submit them to the Engineer and organize to carry out the

20 MW (AC) Solar PV Power Plant at Dugdha, BCCL- Dhanbad, Jharkhand

Tender No.
.....



Bharat Coking Coal Limited

Tender for Design, Engineering, Procurement & Supply, Construction & Erection, Testing, Commissioning, Associated Transmission System and Comprehensive O&M for 5 (Five) Years of 20 MW (AC)/28 MWp (DC) Solar PV Power Plant and connecting Transmission lines at Dugdha Washery, BCCL- Dhanbad



tests as scheduled/agreed.

4 Sampling and Testing of Construction Materials

- 4.1** The method of sampling for testing of construction materials and work / job samples shall be as per the relevant BIS / standards / codes and in line with the requirements of the technical specifications / quality plans.
- 4.2** All samples shall be jointly drawn, signed and sealed wherever required, by the contractor and the engineer or his authorized representative.
- 4.3** The contractor shall carry out testing in accordance with the relevant IS standards/ codes and in line with the requirements of the technical specifications / quality plans. Where no specific testing procedure is mentioned, the tests shall be carried out as per the best prevalent engineering practices and to the directions of the Engineer.
- 4.4** All testing shall be done in the presence of Engineer or his authorized representative in a NABL accredited / Govt. Laboratory acceptable to Engineer.
- 4.5** The test samples shall be jointly selected and sealed and signed by the Site-in-charge and thereafter these shall be sent to the concerned laboratory.
- 4.6** The test report along with the recommendations shall be obtained from the laboratory without delay and submitted to Engineer.

5 Purchase and Service

- 5.1** All structural steel shall be procured only from main steel producers. In case of non-availability of some of the sections with main steel producers, the contractor may propose to procure the sections from the re-rollers of the main steel producers, the name of such re-rollers will have to be cleared by the Engineer for which details such as BIS approval, main steel producer's approval, past experience for production of sections of specified material, details of machines, plant, testing facilities etc.
- 5.2** Confirmation that the process control and manufacturing of steel sections by re-rollers shall be same as that of main steel producers, that billets for re-rolling will only be sourced from main steel producers shall be furnished with regard to re-roller.
- 5.3** For Module Mounting Structures (MMS), sources of steel other than those specified under this clause may also be used subject to the condition that they otherwise meet the requirements of the Technical Specifications / Bid documents. Even after clearance of re-rollers, induction of billets with identified and correlated Mill test certificates (MTC) in the process of re-rolling,

20 MW (AC) Solar PV Power Plant at Dugdha, BCCL- Dhanbad, Jharkhand	<u>Tender No.</u> <u>.....</u>	150 Page
--	--	-------------------



Bharat Coking Coal Limited

Tender for Design, Engineering, Procurement & Supply, Construction & Erection, Testing, Commissioning, Associated Transmission System and Comprehensive O&M for 5 (Five) Years of 20 MW (AC)/28 MWp (DC) Solar PV Power Plant and connecting Transmission lines at Dugdha Washery, BCCL- Dhanbad



CNUL

sampling of steel, quality checks thereof and stamping of final product for further identification and correlation with MTC prior to dispatch shall be the responsibility of the contractor and these shall be performed in presence of the authorized representative of the main Contractor.

5.4 Reinforcement steel shall be procured only from main steel producers and Mill test certificates (MTC) shall be obtained and submitted to the Engineer for correlation.

6 Field Quality Plan

6.1 Well before the start of the work, the contractor shall prepare and submit the Field Quality Plans to Employer for approval, which shall detail out for all the works, equipment, services, quality practices and procedures etc. in line with the requirement of the technical specifications to be followed by the contractor at site.

6.2 This FQP shall cover all the items / activities covered in the contract / schedule of items required, right from material procurement to completion of the work at site.

6.3 An Indicative Field & Manufacturing Quality Plan for civil, structural and MMS works is enclosed with this specification for reference as Annexure-B.

7 General QA Requirements

7.1 The contractor shall ensure that the works, BOIs and services under the scope of Contract, whether manufactured or performed within contractor's works or at his subcontractor's premises or at the project site or at any other place of work, are in accordance with Technical specification, applicable standards / codes, approved drawings / data sheets / quality plans and BOQ. All the works, BOIs and services shall be carried out as per the best prevalent engineering practices and to the directions of the Engineer.

Equipment	UOM	Approx. Qty.
Cube moulds for cement testing	nos.	4
Sieve shaker	nos.	1
Sieve for sand, coarse and fine aggregate	set	1
Sieve for coarse aggregate	set	1
Slump testing equipment	nos.	6
Oven	nos.	2
Physical balance	nos.	1



Bharat Coking Coal Limited

Tender for Design, Engineering, Procurement & Supply, Construction & Erection, Testing, Commissioning, Associated Transmission System and Comprehensive O&M for 5 (Five) Years of 20 MW (AC)/28 MWp (DC) Solar PV Power Plant and connecting Transmission lines at Dugdha Washery, BCCL- Dhanbad



Thermometer	nos.	4
Burret	nos.	2
Measuring cylinder	nos.	9
Measuring flask	nos.	3
Compression testing machine	set	1
Cube mould for concrete	nos.	10
Mechanical weighing machine	nos.	1 (100kg capacity)
Drum type concrete mixer (for trial mixes)	nos.	1
Proctor testing equipment	set	1

7.2 Notes

7.3 The equipment listed above is indicative and minimum required. Additional equipment,if any, required for successful completion of work shall be provided /arranged by the contractor.

7.4 All test reports/ inspection reports shall be submitted in soft copy also and shall be available at site for easy access to the Engineer.

7.5 Based on the schedule (L2/L3 Network), Quality control & Quality Assurance Work planshall be finalized by the contractor and the same shall be submitted to Engineer for acceptance/approval.



Bharat Coking Coal Limited

Tender for Design, Engineering, Procurement & Supply, Construction & Erection, Testing, Commissioning, Associated Transmission System and Comprehensive O&M for 5 (Five) Years of 20 MW (AC)/28 MWp (DC) Solar PV Power Plant and connecting Transmission lines at Dugdha Washery, BCCL- Dhanbad



E Performance Measurement Procedure

1 Performance Ratio (PR)

Performance Ratio (PR) test for Operational Acceptance of the plant shall be performed as per the procedure attached in Annexure-C.

2 Capacity Utilization Factor (CUF)

Capacity Utilization Factor of the plant shall be calculated as per the procedure attached in Annexure-C.



Bharat Coking Coal Limited

Tender for Design, Engineering, Procurement & Supply, Construction & Erection, Testing, Commissioning, Associated Transmission System and Comprehensive O&M for 5 (Five) Years of 20 MW (AC)/28 MWp (DC) Solar PV Power Plant and connecting Transmission lines at Dugdha Washery, BCCL- Dhanbad



SECTION – VII

C. SPECIAL TECHNICAL CONDITIONS

20 MW (AC) Solar PV Power Plant at Dugdha, BCCL- Dhanbad, Jharkhand

Tender No.

.....

154 | Page



Bharat Coking Coal Limited

Tender for Design, Engineering, Procurement & Supply, Construction & Erection, Testing, Commissioning, Associated Transmission System and Comprehensive O&M for 5 (Five) Years of 20 MW (AC)/28 MWp (DC) Solar PV Power Plant and connecting Transmission lines at Dugdha Washery, BCCL- Dhanbad



CNUL

- 1 The Contractor is advised to ascertain the availability of good quality ground water at site for construction, drinking and module cleaning purpose. In case of non-availability of ground water source, the contractor shall explore the option of supply of water through water tankers. In case the water quality is not suitable for drinking or module cleaning purpose, the Contractor shall install suitable water treatment facilities.
- 2 The lands are covered with small trees, seasonal crops and long bushes. Clearance of such trees and bushes shall be under the scope the Contractor. The land profile is generally flat with some undulations and would require some land development work which shall be under the scope of the contractor as elaborated under Cl. 5 (Area Grading and Land Development) under Section VII-B (Technical Specifications) of the NIT.
- 3 The Contractor is advised to inspect the sites and study the nature of soil, topography and other conditions to decide the extent of scope of area grading, ground compaction, and foundation system to be provided before submission of the Bid. The Employer shall not be responsible for any variations in soil characteristics and other conditions, between those observed during preliminary site visit and detailed investigations to be carried out by the Contractor during contract execution.
- 4 Design Considerations for all structural works are provided below:

Design Parameters	Dugdha Washery, BCCL
Global Horizontal Irradiation (kWh/m ² /month):	1785.5
Diffused Horizontal Irradiation (kWh/m ² /month):	847.6
Average Temperature (° C):	25.9
Wind Velocity (m/s):	2.1
Linke Turbidity (-):	5.926
Relative Humidity (%):	49.0

5 Power Conditioning Units (TS Part B Clause 4)

Power Conditioning Unit shall be outdoor type, installed on plinth comprising of RCC framed structure with foundations, columns and beams up to plinth level (FFL), with a suitable metal canopy on top.

6 HT Switchgear (TS Part B Clause 6)

HT Switchgear shall be outdoor type, installed on plinth comprising of RCC framed structure with foundations, columns and beams up to plinth level (FFL), with a suitable metal canopy on



Bharat Coking Coal Limited

Tender for Design, Engineering, Procurement & Supply, Construction & Erection, Testing, Commissioning, Associated Transmission System and Comprehensive O&M for 5 (Five) Years of 20 MW (AC)/28 MWp (DC) Solar PV Power Plant and connecting Transmission lines at Dugdha Washery, BCCL- Dhanbad



top.

- 7 Plant fencing for each plot shall be of Chain Link Type as per the drawing provided in this section.
- 8 Main Entry gate for each plot shall be as per the drawing provided in this section.
- 9 MCR shall be RCC Type Building sand shall conform to the provisions as specified in Technical Specifications.



Bharat Coking Coal Limited

Tender for Design, Engineering, Procurement & Supply, Construction & Erection, Testing, Commissioning, Associated Transmission System and Comprehensive O&M for 5 (Five) Years of 20 MW (AC)/28 MWp (DC) Solar PV Power Plant and connecting Transmission lines at Dugdha Washery, BCCL- Dhanbad



Annexure – A

Pre-dispatch Inspection Protocol for Crystalline PV Modules by Employer or Employer Deputed Agency

**20 MW (AC) Solar PV Power
Plant at Dugdha, BCCL-
Dhanbad, Jharkhand**

Tender No.

.....

157 | Page



Bharat Coking Coal Limited

Tender for Design, Engineering, Procurement & Supply, Construction & Erection, Testing, Commissioning, Associated Transmission System and Comprehensive O&M for 5 (Five) Years of 20 MW (AC)/28 MWp (DC) Solar PV Power Plant and connecting Transmission lines at Dugdha Washery, BCCL- Dhanbad



Contents

1. Objective: 158

2. Standard: 158

3. Definitions: 158

4. Inspection Schedule: 158

5. Scope of Inspection..... 159

6. Sampling Process 159

7. Decision Rules for Acceptance/Rejection..... 160

8. Inspection Process..... 160

9. Re-inspection and review..... 161

10. Inspection Summary 161

11. Disclaimer: 161



Bharat Coking Coal Limited

Tender for Design, Engineering, Procurement & Supply, Construction & Erection, Testing, Commissioning, Associated Transmission System and Comprehensive O&M for 5 (Five) Years of 20 MW (AC)/28 MWp (DC) Solar PV Power Plant and connecting Transmission lines at Dugdha Washery, BCCL- Dhanbad



Pre-dispatch inspection procedure

1. Objective:

The objective of this document is to establish General inspection protocol with objectivity for verification of Quality Parameters of Solar Modules by the customer (or its authorised inspection agency) prior to dispatch. The decision rules and procedure specified herein seek to uphold quality standards based on industry best practices and technical specifications laid out in tender documents as well as to control risks associated with item procurement.

2. Standards and Codes:

1. Sampling for determining Acceptance Quality Level (AQL) shall follow ISO 2859-1:1999.
2. IEC TS 60904-1-2:2019 - Photovoltaic devices - Part 1-2: Measurement of current-voltage characteristics of bifacial photovoltaic (PV) devices

3. Definitions:

1. Lot: All products/items manufactured in one batch.
Notwithstanding the aforementioned definition, the customer or authorized inspection agency can lay down alternate/additional criteria for determining a lot.
2. Major Defect: A defect that reduces the usability or causes the product to fail to fulfil its nominal characteristic function.
3. Minor Defect: A defect that does not reduce the usability of the product, but does not meet the quality standard.

4. Inspection Schedule:

Customer representative shall propose the schedule for Pre-despatch Inspection of Finished Goods to the Customer well in advance, and in no case less than 3 working days prior to commencement of Inspection at a location within India and 7 days in case of a foreign country.

5. Scope of Inspection:

Supplier representative will accompany the Inspector while doing the inspection which shall typically consist of 2 steps for clearance of each Lot:

BOM verification: To be conducted prior to the commencement of production.

20 MW (AC) Solar PV Power Plant at Dugdha, BCCL- Dhanbad, Jharkhand	<u>Tender No.</u> <u>.....</u>	159 Page
--	--	-------------------



Bharat Coking Coal Limited

Tender for Design, Engineering, Procurement & Supply, Construction & Erection, Testing, Commissioning, Associated Transmission System and Comprehensive O&M for 5 (Five) Years of 20 MW (AC)/28 MWp (DC) Solar PV Power Plant and connecting Transmission lines at Dugdha Washery, BCCL- Dhanbad



CNUL

The details of materials used will be verified from the ERP/Manufacturing data and corroborated with the Construction Data Form (CDF). This shall include verification of following:

Item	Method of Verification
Shelf life of the following BOM items: <ul style="list-style-type: none"> EVA PV Module Back sheet Sealant and potting material (Silicone) 	Verify the expiry date/shelf life and storage conditions <i>The PV Module manufacturer shall submit all required information to prove that materials being used are within their shelf life.</i>

Note: Supplier shall provide the necessary documents for approval of BOM as per IEC standards and tender Technical Specifications.

Witness Tests:

Manufacturer shall assist the Inspecting agency to witness following checks, the detailsof which are provided elsewhere in this document:

- I. Flash test- As per sampling Plan
For Bifacial Modules, Measurement of current-voltage characteristics shall bedone as per IEC TS 60904-1-2:2019 - Photovoltaic devices - Part 1-2
- II. Visual Inspection- As per sampling Plan
- III. EL Inspection-As per Sampling Plan
- IV. Electrical Characteristics (Other than Flash Test)- As per Sampling Plan

Note: The Supplier shall furnish soft and hard copy of the Production Quality Plan priorto commencement of the Inspection.

6. Sampling Process:

- a. Supplier shall provide the list of modules in a lot ready for despatch, along with flashtest data (Measured Electrical Data, P_{max}) prior to commencement of Inspection tests.**Note:** Smallest lot size for Inspection: 20% of the capacity as per the PO.
- b. Supplier will arrange to move the PV Modules from FG to Inspection area.
- c. Same samples shall be used for all Witness Tests stated at 5.2 above.
- d. Inspector shall commence Inspection process by randomly selecting samples from the list of



Bharat Coking Coal Limited

Tender for Design, Engineering, Procurement & Supply, Construction & Erection, Testing, Commissioning, Associated Transmission System and Comprehensive O&M for 5 (Five) Years of 20 MW (AC)/28 MWp (DC) Solar PV Power Plant and connecting Transmission lines at Dugdha Washery, BCCL- Dhanbad



serial nos. (pallet-wise) provided by Supplier as per ISO 2859: Single Sampling Plan for Normal Inspection, General Inspection plan level-I. However, the Inspector shall reserve the right to switch to tightened or reduced level of Inspection as per the lot quality.

7. Decision Rules for Acceptance/Rejection

Following is a summary of Decision Rules for Acceptance/Rejection of a given Sample in a lot offered for Inspection:

Table 1: AQL Levels

Defect Type	AQL (%)
Major (Ma)	2.5
Minor (Mi)	4

Table 2: Inspection Levels

Inspection steps	Inspection item	Inspection level
1	Flash Test	General inspection level I
2	Visual	General inspection level I
3	EL	General inspection level I
4	EC (Other than Flash Test)	10 Nos. per lot

8. Inspection Process

a. Electrical Inspection – Flash Tests

For Electrical inspection following preparation will be done:

- Module Temp Stabilization: Modules will be kept in controlled environmental condition till it reaches 25 ±2°C
- Calibration of Sun-simulator: Sun-simulator will be calibrated as per Calibration Reference. Reference should be calibrated against Calibration Reference tested from reputed testing lab TUV / Fraunhofer etc. Testing of modules will be done at STC condition, AM=1.5

Note:

- (i) All modules selected for sampling inspection will be re-tested in the sun- simulator.



Bharat Coking Coal Limited

Tender for Design, Engineering, Procurement & Supply, Construction & Erection, Testing, Commissioning, Associated Transmission System and Comprehensive O&M for 5 (Five) Years of 20 MW (AC)/28 MWp (DC) Solar PV Power Plant and connecting Transmission lines at Dugdha Washery, BCCL- Dhanbad



A Pmax retest (repeatability test) variation of ± 2 % on actual flash Pmax value will be acceptable.

(ii) The Supplier shall provide a valid calibration certificate of the apparatus used.

b. Visual Inspection:

- Customer representative will verify the module visual characteristics as per the Visual Acceptance norms.
- The Visual Inspection shall be carried out in a well-lit room. It shall be the responsibility of the Supplier to ensure adequate brightness in the room.

c. Electroluminescence (EL) Inspection:

- The EL image shall have sufficient resolution for analysis of defects.
- Hi-pot test shall be done as per IEC procedure. The Supplier shall provide a valid calibration certificate of the apparatus used.

9. Re-inspection and review

In case of minor non-conformities like cleaning issues, label mismatch, etc. which can be easily reworked, Supplier shall rework/replace the modules and offer them for re- inspection to Inspector.

10. Inspection Summary:

Once the inspection is completed Customer Representative will compile his Inspection Summary Report and share with Supplier and give necessary recommendation on despatch depending upon the audit findings based on the observations made. This report shall be provided within same day of inspection (Format Attached).

11. Disclaimer:

Inspection by Employer does not absolve the responsibility of the Supplier/vendor to ensure quality during production of the material and its transport to site. Any damages during transport/ handling shall be replaced before erection at site as directed by Engineer-in-charge without any extra cost to the purchaser.



Bharat Coking Coal Limited

Tender for Design, Engineering, Procurement & Supply, Construction & Erection, Testing, Commissioning, Associated Transmission System and Comprehensive O&M for 5 (Five) Years of 20 MW (AC)/28 MWp (DC) Solar PV Power Plant and connecting Transmission lines at Dugdha Washery, BCCL- Dhanbad



Sampling Plan

(Sampling Plan as Per ISO 2859) -1

Table 1 - Sample size code letters (see 10.1 and 10.2)

Lot size	Special inspection levels				General inspection levels		
	S-1	S-2	S-3	S-4	I	II	III
2 to 8	A	A	A	A	A	A	B
9 to 15	A	A	A	A	A	B	C
16 to 25	A	A	B	B	B	C	D
26 to 50	A	B	B	C	C	D	E
51 to 90	B	B	C	C	C	E	F
91 to 150	B	B	C	D	D	F	G
151 to 280	B	C	D	E	E	G	H
281 to 500	B	C	D	E	F	H	J
501 to 1 200	C	C	E	F	G	J	K
1 201 to 3 200	C	D	E	G	H	K	L
3 201 to 10 000	C	D	F	G	J	L	M
10 001 to 35 000	C	D	F	H	K	M	N
35 001 to 150 000	D	E	G	J	L	N	P
150 001 to 500 000	D	E	G	J	M	P	Q
500 001 and over	D	E	H	K	N	Q	R



Bharat Coking Coal Limited

Tender for Design, Engineering, Procurement & Supply, Construction & Erection, Testing, Commissioning, Associated Transmission System and Comprehensive O&M for 5 (Five) Years of 20 MW (AC)/28 MWp (DC) Solar PV Power Plant and connecting Transmission lines at Dugdha Washery, BCCL- Dhanbad



(Sampling Plan as Per ISO 2859) – 2 – Normal, Tightened and Reduced)

Table 2-A — Single sampling plans for normal inspection (Master table)

Sample size code letter	Acceptance quality limit, AQL, in percent nonconforming items and nonconformities per 100 items (normal inspection)																										
	0.010	0.015	0.025	0.040	0.065	0.10	0.15	0.25	0.40	0.65	1.0	1.5	2.5	4.0	6.5	10	15	25	40	65	100	150	250	400	650	1 000	
A	Ac Re	Ac Re	Ac Re	Ac Re	Ac Re	Ac Re	Ac Re	Ac Re	Ac Re	Ac Re	Ac Re	Ac Re	Ac Re	Ac Re	Ac Re	Ac Re	Ac Re	Ac Re	Ac Re	Ac Re	Ac Re	Ac Re	Ac Re	Ac Re	Ac Re	Ac Re	Ac Re
B	Ac Re	Ac Re	Ac Re	Ac Re	Ac Re	Ac Re	Ac Re	Ac Re	Ac Re	Ac Re	Ac Re	Ac Re	Ac Re	Ac Re	Ac Re	Ac Re	Ac Re	Ac Re	Ac Re	Ac Re	Ac Re	Ac Re	Ac Re	Ac Re	Ac Re	Ac Re	Ac Re
C	Ac Re	Ac Re	Ac Re	Ac Re	Ac Re	Ac Re	Ac Re	Ac Re	Ac Re	Ac Re	Ac Re	Ac Re	Ac Re	Ac Re	Ac Re	Ac Re	Ac Re	Ac Re	Ac Re	Ac Re	Ac Re	Ac Re	Ac Re	Ac Re	Ac Re	Ac Re	Ac Re
D	Ac Re	Ac Re	Ac Re	Ac Re	Ac Re	Ac Re	Ac Re	Ac Re	Ac Re	Ac Re	Ac Re	Ac Re	Ac Re	Ac Re	Ac Re	Ac Re	Ac Re	Ac Re	Ac Re	Ac Re	Ac Re	Ac Re	Ac Re	Ac Re	Ac Re	Ac Re	Ac Re
E	Ac Re	Ac Re	Ac Re	Ac Re	Ac Re	Ac Re	Ac Re	Ac Re	Ac Re	Ac Re	Ac Re	Ac Re	Ac Re	Ac Re	Ac Re	Ac Re	Ac Re	Ac Re	Ac Re	Ac Re	Ac Re	Ac Re	Ac Re	Ac Re	Ac Re	Ac Re	Ac Re
F	Ac Re	Ac Re	Ac Re	Ac Re	Ac Re	Ac Re	Ac Re	Ac Re	Ac Re	Ac Re	Ac Re	Ac Re	Ac Re	Ac Re	Ac Re	Ac Re	Ac Re	Ac Re	Ac Re	Ac Re	Ac Re	Ac Re	Ac Re	Ac Re	Ac Re	Ac Re	Ac Re
G	Ac Re	Ac Re	Ac Re	Ac Re	Ac Re	Ac Re	Ac Re	Ac Re	Ac Re	Ac Re	Ac Re	Ac Re	Ac Re	Ac Re	Ac Re	Ac Re	Ac Re	Ac Re	Ac Re	Ac Re	Ac Re	Ac Re	Ac Re	Ac Re	Ac Re	Ac Re	Ac Re
H	Ac Re	Ac Re	Ac Re	Ac Re	Ac Re	Ac Re	Ac Re	Ac Re	Ac Re	Ac Re	Ac Re	Ac Re	Ac Re	Ac Re	Ac Re	Ac Re	Ac Re	Ac Re	Ac Re	Ac Re	Ac Re	Ac Re	Ac Re	Ac Re	Ac Re	Ac Re	Ac Re
J	Ac Re	Ac Re	Ac Re	Ac Re	Ac Re	Ac Re	Ac Re	Ac Re	Ac Re	Ac Re	Ac Re	Ac Re	Ac Re	Ac Re	Ac Re	Ac Re	Ac Re	Ac Re	Ac Re	Ac Re	Ac Re	Ac Re	Ac Re	Ac Re	Ac Re	Ac Re	Ac Re
K	Ac Re	Ac Re	Ac Re	Ac Re	Ac Re	Ac Re	Ac Re	Ac Re	Ac Re	Ac Re	Ac Re	Ac Re	Ac Re	Ac Re	Ac Re	Ac Re	Ac Re	Ac Re	Ac Re	Ac Re	Ac Re	Ac Re	Ac Re	Ac Re	Ac Re	Ac Re	Ac Re
L	Ac Re	Ac Re	Ac Re	Ac Re	Ac Re	Ac Re	Ac Re	Ac Re	Ac Re	Ac Re	Ac Re	Ac Re	Ac Re	Ac Re	Ac Re	Ac Re	Ac Re	Ac Re	Ac Re	Ac Re	Ac Re	Ac Re	Ac Re	Ac Re	Ac Re	Ac Re	Ac Re
M	Ac Re	Ac Re	Ac Re	Ac Re	Ac Re	Ac Re	Ac Re	Ac Re	Ac Re	Ac Re	Ac Re	Ac Re	Ac Re	Ac Re	Ac Re	Ac Re	Ac Re	Ac Re	Ac Re	Ac Re	Ac Re	Ac Re	Ac Re	Ac Re	Ac Re	Ac Re	Ac Re
N	Ac Re	Ac Re	Ac Re	Ac Re	Ac Re	Ac Re	Ac Re	Ac Re	Ac Re	Ac Re	Ac Re	Ac Re	Ac Re	Ac Re	Ac Re	Ac Re	Ac Re	Ac Re	Ac Re	Ac Re	Ac Re	Ac Re	Ac Re	Ac Re	Ac Re	Ac Re	Ac Re
P	Ac Re	Ac Re	Ac Re	Ac Re	Ac Re	Ac Re	Ac Re	Ac Re	Ac Re	Ac Re	Ac Re	Ac Re	Ac Re	Ac Re	Ac Re	Ac Re	Ac Re	Ac Re	Ac Re	Ac Re	Ac Re	Ac Re	Ac Re	Ac Re	Ac Re	Ac Re	Ac Re
Q	Ac Re	Ac Re	Ac Re	Ac Re	Ac Re	Ac Re	Ac Re	Ac Re	Ac Re	Ac Re	Ac Re	Ac Re	Ac Re	Ac Re	Ac Re	Ac Re	Ac Re	Ac Re	Ac Re	Ac Re	Ac Re	Ac Re	Ac Re	Ac Re	Ac Re	Ac Re	Ac Re
R	Ac Re	Ac Re	Ac Re	Ac Re	Ac Re	Ac Re	Ac Re	Ac Re	Ac Re	Ac Re	Ac Re	Ac Re	Ac Re	Ac Re	Ac Re	Ac Re	Ac Re	Ac Re	Ac Re	Ac Re	Ac Re	Ac Re	Ac Re	Ac Re	Ac Re	Ac Re	Ac Re

↘ = Use the first sampling plan below the arrow. If sample size equals, or exceeds, lot size, carry out 100 % inspection.

↙ = Use the first sampling plan above the arrow.

Ac = Acceptance number

Re = Rejection number

20 MW (AC) Solar PV Power Plant at Dugdha, BCCL- Dhanbad, Jharkhand

Tender No.

164 | Page



Bharat Coking Coal Limited

Tender for Design, Engineering, Procurement & Supply, Construction & Erection, Testing, Commissioning, Associated Transmission System and Comprehensive O&M for 5 (Five) Years of 20 MW (AC)/28 MWp (DC) Solar PV Power Plant and connecting Transmission lines at Dugdha Washery, BCCL- Dhanbad



Table 2-B — Single sampling plans for tightened inspection (Master table)

Sample size code letter	Acceptance quality limit, AQL, in percent nonconforming items and nonconformities per 100 items (tightened inspection)																				
	0.010	0.015	0.025	0.040	0.065	1.0	1.5	2.5	4.0	6.5	10	15	25	40	65	100	150	250	400	650	1 000
	Ac Re	Ac Re	Ac Re	Ac Re	Ac Re	Ac Re	Ac Re	Ac Re	Ac Re	Ac Re	Ac Re	Ac Re	Ac Re	Ac Re	Ac Re	Ac Re	Ac Re	Ac Re	Ac Re	Ac Re	Ac Re
A	↔	↔	↔	↔	↔	↔	↔	↔	↔	↔	↔	↔	↔	↔	↔	↔	↔	↔	↔	↔	↔
B	↔	↔	↔	↔	↔	↔	↔	↔	↔	↔	↔	↔	↔	↔	↔	↔	↔	↔	↔	↔	↔
C	↔	↔	↔	↔	↔	↔	↔	↔	↔	↔	↔	↔	↔	↔	↔	↔	↔	↔	↔	↔	↔
D	↔	↔	↔	↔	↔	↔	↔	↔	↔	↔	↔	↔	↔	↔	↔	↔	↔	↔	↔	↔	↔
E	↔	↔	↔	↔	↔	↔	↔	↔	↔	↔	↔	↔	↔	↔	↔	↔	↔	↔	↔	↔	↔
F	↔	↔	↔	↔	↔	↔	↔	↔	↔	↔	↔	↔	↔	↔	↔	↔	↔	↔	↔	↔	↔
G	↔	↔	↔	↔	↔	↔	↔	↔	↔	↔	↔	↔	↔	↔	↔	↔	↔	↔	↔	↔	↔
H	↔	↔	↔	↔	↔	↔	↔	↔	↔	↔	↔	↔	↔	↔	↔	↔	↔	↔	↔	↔	↔
J	↔	↔	↔	↔	↔	↔	↔	↔	↔	↔	↔	↔	↔	↔	↔	↔	↔	↔	↔	↔	↔
K	↔	↔	↔	↔	↔	↔	↔	↔	↔	↔	↔	↔	↔	↔	↔	↔	↔	↔	↔	↔	↔
L	↔	↔	↔	↔	↔	↔	↔	↔	↔	↔	↔	↔	↔	↔	↔	↔	↔	↔	↔	↔	↔
M	↔	↔	↔	↔	↔	↔	↔	↔	↔	↔	↔	↔	↔	↔	↔	↔	↔	↔	↔	↔	↔
N	↔	↔	↔	↔	↔	↔	↔	↔	↔	↔	↔	↔	↔	↔	↔	↔	↔	↔	↔	↔	↔
P	↔	↔	↔	↔	↔	↔	↔	↔	↔	↔	↔	↔	↔	↔	↔	↔	↔	↔	↔	↔	↔
Q	↔	↔	↔	↔	↔	↔	↔	↔	↔	↔	↔	↔	↔	↔	↔	↔	↔	↔	↔	↔	↔
R	↔	↔	↔	↔	↔	↔	↔	↔	↔	↔	↔	↔	↔	↔	↔	↔	↔	↔	↔	↔	↔
S	↔	↔	↔	↔	↔	↔	↔	↔	↔	↔	↔	↔	↔	↔	↔	↔	↔	↔	↔	↔	↔

↔ = Use the first sampling plan below the arrow. If sample size equals, or exceeds, lot size, carry out 100% inspection.

↔ = Use the first sampling plan above the arrow.

Ac = Acceptance number

Re = Rejection number



Bharat Coking Coal Limited

Tender for Design, Engineering, Procurement & Supply, Construction & Erection, Testing, Commissioning, Associated Transmission System and Comprehensive O&M for 5 (Five) Years of 20 MW (AC)/28 MWp (DC) Solar PV Power Plant and connecting Transmission lines at Dugdha Washery, BCCL- Dhanbad



CNUL

Table 2-C — Single sampling plans for reduced inspection (Master table)

Sample size code letter	Acceptance quality limit, AQL, in percent nonconforming items and nonconformities per 100 items (reduced inspection)																											
	0,010	0,015	0,025	0,040	0,065	0,10	0,15	0,25	0,40	0,65	1,0	1,5	2,5	4,0	6,5	10	15	25	40	65	100	150	250	400	650	1 000		
A	Ac Re	Ac Re	Ac Re	Ac Re	Ac Re	Ac Re	Ac Re	Ac Re	Ac Re	Ac Re	Ac Re	Ac Re	Ac Re	Ac Re	Ac Re	Ac Re	Ac Re	Ac Re	Ac Re	Ac Re	Ac Re	Ac Re	Ac Re	Ac Re	Ac Re	Ac Re	Ac Re	Ac Re
B	Ac Re	Ac Re	Ac Re	Ac Re	Ac Re	Ac Re	Ac Re	Ac Re	Ac Re	Ac Re	Ac Re	Ac Re	Ac Re	Ac Re	Ac Re	Ac Re	Ac Re	Ac Re	Ac Re	Ac Re	Ac Re	Ac Re	Ac Re	Ac Re	Ac Re	Ac Re	Ac Re	Ac Re
C	Ac Re	Ac Re	Ac Re	Ac Re	Ac Re	Ac Re	Ac Re	Ac Re	Ac Re	Ac Re	Ac Re	Ac Re	Ac Re	Ac Re	Ac Re	Ac Re	Ac Re	Ac Re	Ac Re	Ac Re	Ac Re	Ac Re	Ac Re	Ac Re	Ac Re	Ac Re	Ac Re	Ac Re
D	Ac Re	Ac Re	Ac Re	Ac Re	Ac Re	Ac Re	Ac Re	Ac Re	Ac Re	Ac Re	Ac Re	Ac Re	Ac Re	Ac Re	Ac Re	Ac Re	Ac Re	Ac Re	Ac Re	Ac Re	Ac Re	Ac Re	Ac Re	Ac Re	Ac Re	Ac Re	Ac Re	Ac Re
E	Ac Re	Ac Re	Ac Re	Ac Re	Ac Re	Ac Re	Ac Re	Ac Re	Ac Re	Ac Re	Ac Re	Ac Re	Ac Re	Ac Re	Ac Re	Ac Re	Ac Re	Ac Re	Ac Re	Ac Re	Ac Re	Ac Re	Ac Re	Ac Re	Ac Re	Ac Re	Ac Re	Ac Re
F	Ac Re	Ac Re	Ac Re	Ac Re	Ac Re	Ac Re	Ac Re	Ac Re	Ac Re	Ac Re	Ac Re	Ac Re	Ac Re	Ac Re	Ac Re	Ac Re	Ac Re	Ac Re	Ac Re	Ac Re	Ac Re	Ac Re	Ac Re	Ac Re	Ac Re	Ac Re	Ac Re	Ac Re
G	Ac Re	Ac Re	Ac Re	Ac Re	Ac Re	Ac Re	Ac Re	Ac Re	Ac Re	Ac Re	Ac Re	Ac Re	Ac Re	Ac Re	Ac Re	Ac Re	Ac Re	Ac Re	Ac Re	Ac Re	Ac Re	Ac Re	Ac Re	Ac Re	Ac Re	Ac Re	Ac Re	Ac Re
H	Ac Re	Ac Re	Ac Re	Ac Re	Ac Re	Ac Re	Ac Re	Ac Re	Ac Re	Ac Re	Ac Re	Ac Re	Ac Re	Ac Re	Ac Re	Ac Re	Ac Re	Ac Re	Ac Re	Ac Re	Ac Re	Ac Re	Ac Re	Ac Re	Ac Re	Ac Re	Ac Re	Ac Re
J	Ac Re	Ac Re	Ac Re	Ac Re	Ac Re	Ac Re	Ac Re	Ac Re	Ac Re	Ac Re	Ac Re	Ac Re	Ac Re	Ac Re	Ac Re	Ac Re	Ac Re	Ac Re	Ac Re	Ac Re	Ac Re	Ac Re	Ac Re	Ac Re	Ac Re	Ac Re	Ac Re	Ac Re
K	Ac Re	Ac Re	Ac Re	Ac Re	Ac Re	Ac Re	Ac Re	Ac Re	Ac Re	Ac Re	Ac Re	Ac Re	Ac Re	Ac Re	Ac Re	Ac Re	Ac Re	Ac Re	Ac Re	Ac Re	Ac Re	Ac Re	Ac Re	Ac Re	Ac Re	Ac Re	Ac Re	Ac Re
L	Ac Re	Ac Re	Ac Re	Ac Re	Ac Re	Ac Re	Ac Re	Ac Re	Ac Re	Ac Re	Ac Re	Ac Re	Ac Re	Ac Re	Ac Re	Ac Re	Ac Re	Ac Re	Ac Re	Ac Re	Ac Re	Ac Re	Ac Re	Ac Re	Ac Re	Ac Re	Ac Re	Ac Re
M	Ac Re	Ac Re	Ac Re	Ac Re	Ac Re	Ac Re	Ac Re	Ac Re	Ac Re	Ac Re	Ac Re	Ac Re	Ac Re	Ac Re	Ac Re	Ac Re	Ac Re	Ac Re	Ac Re	Ac Re	Ac Re	Ac Re	Ac Re	Ac Re	Ac Re	Ac Re	Ac Re	Ac Re
N	Ac Re	Ac Re	Ac Re	Ac Re	Ac Re	Ac Re	Ac Re	Ac Re	Ac Re	Ac Re	Ac Re	Ac Re	Ac Re	Ac Re	Ac Re	Ac Re	Ac Re	Ac Re	Ac Re	Ac Re	Ac Re	Ac Re	Ac Re	Ac Re	Ac Re	Ac Re	Ac Re	Ac Re
P	Ac Re	Ac Re	Ac Re	Ac Re	Ac Re	Ac Re	Ac Re	Ac Re	Ac Re	Ac Re	Ac Re	Ac Re	Ac Re	Ac Re	Ac Re	Ac Re	Ac Re	Ac Re	Ac Re	Ac Re	Ac Re	Ac Re	Ac Re	Ac Re	Ac Re	Ac Re	Ac Re	Ac Re
Q	Ac Re	Ac Re	Ac Re	Ac Re	Ac Re	Ac Re	Ac Re	Ac Re	Ac Re	Ac Re	Ac Re	Ac Re	Ac Re	Ac Re	Ac Re	Ac Re	Ac Re	Ac Re	Ac Re	Ac Re	Ac Re	Ac Re	Ac Re	Ac Re	Ac Re	Ac Re	Ac Re	Ac Re
R	Ac Re	Ac Re	Ac Re	Ac Re	Ac Re	Ac Re	Ac Re	Ac Re	Ac Re	Ac Re	Ac Re	Ac Re	Ac Re	Ac Re	Ac Re	Ac Re	Ac Re	Ac Re	Ac Re	Ac Re	Ac Re	Ac Re	Ac Re	Ac Re	Ac Re	Ac Re	Ac Re	Ac Re

↕ = Use the first sampling plan below the arrow. If sample size equals, or exceeds, lot size, carry out 100 % inspection.

↕ = Use the first sampling plan above the arrow.

Ac = Acceptance number

Re = Rejection number

20 MW (AC) Solar PV Power Plant at Dugdha, BCCL- Dhanbad, Jharkhand

Tender No.

166 | Page



Bharat Coking Coal Limited

Tender for Design, Engineering, Procurement & Supply, Construction & Erection, Testing, Commissioning, Associated Transmission System and Comprehensive O&M for 5 (Five) Years of 20 MW (AC)/28 MWp (DC) Solar PV Power Plant and connecting Transmission lines at Dugdha Washery, BCCL- Dhanbad



CUSTOMER INSPECTION REPORT			
Ref. No. & Date:			
Client:	PMC:	EPC Contractor:PO	
		Ref. No.:	
Place of Inspection:	Date of inspection:	Lot Size	Sample Quantity
Problem Quantity:			
Detail:			
<u>Inspection Result (OK/Not OK):</u>			
Visual Inspection			
Problem			
Quantity:Detail:			
Flash Test			
Problem			
Quantity:Detail:			
EL Inspection:			
Problem			
Quantity:Detail:			
EC Inspection (Hipot,DC Continuity,IR):Problem Quantity:			
Detail:			
Any Other Criteria/Remarks:			
Is the shipment qualified to be released?		Yes	No
From Client	From EPC Contractor		

Enclosed: Test Details, Flash Test Report, EL test (images- soft copy), EC Test Report

Disclaimer: *This Inspection by SEmployer does not absolve the responsibility of the vendor to ensure quality during production of the material and its transport to site. Any damages during transport/ handling shall be replaced before erection at site as directed by Engineer-in-charge without any extra cost to the purchaser.*

Details:

Lot :				Date
S.No.	Defect	Module Id	Type (Ma/Mi)	Details
1				
2				
....				

	A	B	C	D	E	F	G	H	I	J	K	L	M
	Sr.No.	Activity & Operation	Instruments	Class of Check	Type of Check	Quantum of Check	Reference Documents & Acceptance Standard	Format of Record	D* (Records identified with (√) shall be essentially included by EPC vender in QA documentation)	Cheking Agency			Remarks
								SR - Site Register [*****]-SPV-QA-F-XXX[*****]-SPV-QA-T-XXX (XXX - Inspection recordform No. or Test report format no.)		M'fr/ Supplier or Sub-Contractor	EPC Contractor	[*****] or Owner	
1													
2													
3	1	General Requirements											
4	a	Availability of requisite test set-up and equipment in good working condition with valid calibration at site well before commencement of concerned activity	As required/ agreed	Critical	Physical	Once prior to start of work & Monthly thereafter	Tech. Specs, Construction Drawings	SR	√		x	x	Min. list of equipment - CTM, Set of Seives for CA & FA, Elcometer (digital), Micrometer, Multimeter, Meggar, Torque Wrench, Moulds for casting of concrete/ mortar test samples, Curing tank of adequate size, SS measuring tape - 50m, Theodolite, leveling staff and associated equipment etc. for day to day work with proper storage racks. The equipment shall be in adequate no. matching the site progress requirements. Functioning of laboratory equipment in proper working condition to be verified on monthly basis
5	b	Submission of QA & QC manpower deployment schedule based on agreed L-2 network	As required/ agreed	Critical	Verification	Before start of work	Tech. Specs, Construction Drawings	SR	√		x	x	
6	c	Availability of QA & QC manpower deployment based on agreed deployment schedule, Periodic review for augmentation as per actual progress	As required/ agreed	Critical	Physical	Once prior to start of work & Monthly thereafter	Tech. Specs, Construction Drawings	SR	√		x	x	
7	d	Submission of schedule/ programme of tests and inspection of civil works (survey, excavation, concreting, backfilling, brickwork, finishing works, roads, drains etc.) to be done monthly and quarterly based on agreed schedule	As required/ agreed	Critical	Physical	Once prior to start of work & Monthly/ Quarterly there after	Tech. Specs, Construction Drawings	SR	√	x	x	x	
8	e	Submission of actual work programme in 3 days (72 hours) in advance to facilitate planning for quality checks as per approved QP	As required/ agreed	Critical	Physical	48 hours before start of actual work	Master programme/ schedule	SR	√	x	x	x	
9	f	Stacking and storage of construction materials and components at site	IS: 4062	Critical	Physical	Random	Tech. Specs, Construction Drawings & IS: 4062	SR	√	x	x	x	
11	2	Surveying (Execution phase)											
12	a	Availability of Calibrated Instruments, qualified & experienced staff at site	As required/ agreed	Critical	Physical	100%	Tech. Specs, Construction Drawings, Agreed deployment schedule	Calibration Report	√	x	x	x	
13	b	Ensure correct Boundary Layout and Latitude-Longitude Coordinates, True North	construction Drawings	Critical	Measurement	100%	Tech. Specs, Construction Drawings	SR	√	x	x	x	
14	c	GL (ground level), FGL (finished ground level) and Plinth Level, Check PBM (permanent bench mark) with Total Station/ Theodolite and after conformation carry out Peg marking	As required/ agreed	Critical	Measurement	100%	Construction Drawings	SR	√	x	x	x	
16	3	Materials											
17	A	Cement											
18	i	Fineness											
19	ii	Compressive Strength											
20	iii	Initial & final setting time											
21	iv	Chemical composition of Cement	As per IS: 4031	Critical	Review of MTC/ Physical	One test at Lab to correlate with MTC	IS:456, IS:269, IS:8112, IS:12269, IS:1489, Tech. Specs	Manufacturers Test Certificate (MTC's) and Laboratory Test results	√	x	x	x	Each consignment/ lot of cement shall be duly correlated with MTC. If cement stored is more than 60 days in godown the same shall be re-tested for conformation with MTC

	A	B	C	D	E	F	G	H	I	J	K	L	M							
1	Sr.No.	Activity & Operation	Instruments	Class of Check	Type of Check	Quantum of Check	Reference Documents & Acceptance Standard	Format of Record	D* (Records identified with (√) shall be essentially included by EPC vender in QA documentation)	Cheking Agency			Remarks							
2								SR - Site Register [*****]-SPV-QA-F-XXX[*****]-SPV-QA-T-XXX (XXX - Inspection recordform No. or Test report format no.)		M'fr/ Supplier or Sub-Contractor	EPC Contractor	[*****] or Owner								
23	i	Determination of Particle size (Sieve Analysis), Flakiness index, Elongationindex	As per IS: 2386	Major	Visual	Once per 100 cum or part thereof (During monsoon moisture content tobe checked every day)	IS:383,IS:2386, Tech. Specs	Lab Test results	√	x	x	x	Water content of concrete to be corrected asper results of moisture content							
24	ii	Moisture content		Critical		One test at Lab for each source/ on every change of source			IS:383,IS:2386, Tech. Specs	Lab Test results	√	x		x	x	These tests shall be carried out while establishing design mix. In case of change ofsource the design mix shall be re-validated fornew source				
25	iii	Crushing Value, Impact value, Abrasion value																		
26	iv	Specific Gravity, water absorption																		
27	v	Bulk Density																		
28	vi	Soundness																		
29	vii	Presence of deleterious materials																		
30	C	<i>Fine Aggregate (FA)</i>																		
31	i	Gradation/Determination of Particle size (Sieve Analysis)	Balance, Oven etc.As per IS: 2386, 383	Major	Visual	Gradation - Once per1000 cum or part there of Moisture content - Every day	IS:383,IS:2386,IS:456 , Tech. Specs	Lab Test results	√	x	x	x	Water content of concrete to be corrected asper results of moisture content							
32		Moisture Content																		
33	ii	Specific Gravity and density (for design mix concretes only)	As per IS: 2386, 383	Major	Visual	One test at Lab for each source/ on every change of source								IS:383,IS:2386,IS:456 , Tech. Specs	Lab Test results	√	x	x	x	Water content of concrete to be corrected asper results of moisture content
34	iii	Water absorption (for design mix concretes only)																		
35	iv	Presence of deleterious materials																		
36	D	<i>Concrete Admixture</i>																		
37	i	Type of admixture			Review of MTC	IS: 9103, Approved design mix			√	x	x	x	Admixture shall be of brand and type as per approved design mix. Each lot/ batch of admixurture shall accompany the Manufacturer's Brochure and shall becorrelated with MTC							
38	ii	Physical & Chemical properties			Review of MTC	IS: 9103, Manufacturer's Brochure														
39	iii	Suitability																		
40	E	<i>Bricks</i>																		
41	i	Dimensional Tolerance, shape			Measurement/ Physical	As per relevant IS code/ one sample for30,000 nos. or part there of	IS: 1077, IS: 13757, IS: 12894, Tech. Specs, Construction Drawings	Lab Test results	√	x	x	x	Efflorescence shall be checked at each source							
42	ii	Compressive Strength																		
43	iii	Water Absorption																		
44	iv	Efflorescence																		
45	E	<i>Water</i>																		
46	i	Cleanliness - Test for ascertaining limitof solids		Major		One per 3 months foreach source	IS:456,IS:3025 (part 18), Tech. Specs, Construction Drawings specification	Lab Test reports	√	x	x	x	Water to be used for concrete shall be of potable quality and shall meet requirementspecified in IS: 456							
47	ii	Chemical Tests to ascertain the suitability for construction purposes - pHValue, Sulphate & Chloride content							IS:456,IS:3025 (part 22, 23), Tech. Specs, Construction Drawings	Lab Test reports	√	x		x	x					
48	F	<i>Reinforcement Steel</i>																		
49	i	Identification & Size		Major	Visual	Each batch of delivery	IS:432,IS:1786,IS:1852, Tech Specs	SR	√	x	x	x	Reinforcement steel shall be stored properly at site to avoid rusting							
50	ii	Freedom from cracks, surface flaws, lamination				Random in each shift					√	x		x	x					
51	iii	Tensile Test		Critical	Review of MTC	Each batch of delivery	IS:432,IS:1566,IS:1786, Tech Specs	Manufacturers TestCertificate (MTC's)	√	x	x	x								
52	iv	Yield stress/proof stress																		
53	v	Percentage Elongation																		
54	vi	Bend/Rebend test																		
55	vii	Reverse Bend Test for HDS wire																		
57	3	Structural Steel Work {Example: Chequered plate cover, Panel supports, Rungs, Cat ladder, Inserts, Fencing gate (MS) etc.}							√	x	x	x								

58	i	Structural Steel (Raw material)- Chemical Properties, Ultimate Tensile Strength(UTS), Yield Strength (YS), Percentage Elongation, Bend test		Critical	Review of MTC	For each batch of each section	IS: 2062, IS: 8500, Tech. Specs, Construction Drawings	Manufacturers Test Certificate (MTC's)	√	x	x	x	MTC to be correlated
59	ii	Dimensional Check - [****]tion dimensions, thickness		Critical	Measurement	10% of total quantity at Random			√	x	x	x	For Fencing gate - dimensional check 100%

	A	B	C	D	E	F	G	H	I	J	K	L	M	
1	Sr.No.	Activity & Operation	Instruments	Class of Check	Type of Check	Quantum of Check	Reference Documents & Acceptance Standard	Format of Record	D* (Records identified with (√) shall be essentially included by EPC vender in QA documentation)	Cheking Agency			Remarks	
2								SR - Site Register [*****]-SPV-QA-F-XXX[*****]-SPV-QA-T-XXX (XXX - Inspection recordform No. or Test report format no.)		M'fr/ Supplier or Sub-Contractor	EPC Contractor	[*****] or Owner		
60	iii	Visual checks for damages, rusting, pitting, scaling etc.		Major	Visual	100%	IS: 822, Tech. Specs, Construction Drawings, MTC, relevant BIS standards for painting	Manufacturers Test Certificate (MTC's)/SR	√	x	x	x		
61	iv	Visual checks for welding defects, painting (surface preparation, primercoat, and Finishing coat - make and shade of paint, DFT) as applicable.		Major	Visual/ Measurement/ Review of MTC	10% of total quantity at Random				√	x	x	x	MTC to be correlated
62	v	Acceptance of Structural steel works		Major	Physical/ Acceptance	Random	Tech. Specs, Construction Drawings	SR	√	x	x	x		
64	4	Foundation System												
65	A	Bored Cast in-situ Concrete Piling (for MMS support)												
66	a	Execution												
67	i	Ensuring correctness of layout		Critical	Physical	100%	Tech. Specs, Construction Drawings	SR	√	x	x	x		
68	ii	Checking of pile making as per drawing	Total Station	Major	Visual									
69	iii	Checking of Centre line of Pile Group	Total Station	Critical	Physical									
70	iv	Check Pile Location	Total Station		Measurement									
71	v	GL, Pile depth, diameter and alignment	As required		Measurement									1. During boring of pile, record SPT/ core recovery to ensure socketing length in the hardstrata equivalent in terms of pile diameter in hard rock zone as per tech Specs and approved construction drawings. 2. In case of collapse of pile bore during drilling temporary MS lining shall be used. 3. Lines and levels to be checked 4. Each bore shall be cleaned of any loose materail by pressure jet washing/ cleaning by air jet 5. The column section shall be placed and held in position in true vertical alignment using template/ tripod till initial setting of concrete 6. Concrete garde - as per Construction Drawing
72	vi	Cleaning/ flushing of pile bore	As required	Major	Visual									
73	vii	Insertion & positioning of Column post in the bore hole (in case of embeded col. Leg) Placement of reinforcement and foundation bolts with template (in case of fixing of col. with base plate & foundation bolt assembly)	As required	Critical	Visual/ Measurement			IS 2911, Tech Specs, Construction Drawings	SR	√	x	x	x	
74	viii	Acceptance of Pile casting - Shape, reinforcement or col. leg embedment (as applicable), concreting, compacting with use of needle vibrator etc.	As required/ Agreed	Major	Visual									
75	ix	Grouting u/s of base plate	As required/ Agreed	Critical	Visual	100%	Tech. Specs & Construction drawings	SR	√	x	x	x	The type, grade and thickness of grout shall be as per approved drawing	
76	b	Testing												
77	i	Initial pile load test - Compression (Vertical), Lateral (Horizontal), & Pull out (Tension)	Calibrated dial gauges, jack of required capacity, datum bar setc.	Critical	Physical	100% for 3 no. for each type of test or as specified in Tech Specs, Approved test pile layout	IS 2911, Tech Specs, Construction Drawings	Test Report	√	x	x	x	1. The R/F details shall be as per approved drawing for test pile (if applicable), 2. The test load shall be up to 2.5 times of required pile capacity in case of Compression and Lateral load and 2 times in case of Pull out test as per IS: 2911 (Pt. 4), 3. The location shall be as per approved pile test programme/ layout drawing 4. The test shall be carried out as per approved methodology 5. Test report along with test records shall be submitted in standard format as per IS:2911	

78	ii	Routine pile tests - Pull out and Lateral		Critical	Physical	100% for 0.5% of total no. of working piles for each type of test	IS 2911, Tech Specs, Construction Drawings	Test Report				<p>1. The piles for routine tests shall be selected at Random to represent total no. of job piles installed 2. The test load for vertical and pull out shall be 1.5 times the required pile capacity 3. The test shall be carried out as per approved methodology. 4. The Test report along with test records shall be submitted in standard format as per IS:2971 (Pt. 4)</p>
----	----	---	--	----------	----------	---	--	-------------	--	--	--	--

	A	B	C	D	E	F	G	H	I	J	K	L	M
1	Sr.No.	Activity & Operation	Instruments	Class of Check	Type of Check	Quantum of Check	Reference Documents & Acceptance Standard	Format of Record	D* (Records identified with (√) shall be essentially included by EPC vender in QA documentation)	Cheking Agency			Remarks
2								SR - Site Register [*****]-SPV-QA-F-XXX[*****]-SPV-QA-T-XXX (XXX - Inspection recordform No. or Test report format no.)		M'fr/ Supplier or Sub-Contractor	EPC Contractor	[*****] or Owner	
80	B	Cable Trench/ Building & Equipment Foundations											
81	a	Before Excavation											
82	i	Ensuring correctness of layout		Critical	Physical	100%	Tech. Specs, Construction Drawings	SR	√	x	x	x	
83	ii	Checking of trench marking & alignment		Major	Visual		Tech Specs, Construction Drawings						
84	b	Excavation											
85	i	Dimensional conformity including diagonal check		Critical	Visual / Measurement	100%	IS:3764, Tech Specs, Construction Drawings	SR	√	x	x	x	
86	ii	Excavated earth kept away from edges		Minor	Visual	Random		SR	√	x	x	x	
87	c	Acceptance of Trench/ Foundationcasting - Shape, reinforcement, shuttering, concreting, etc.		Minor	Physical	100%	Tech. Specs, Construction Drawings	SR	√	x	x	x	
89	5	Foundation Bolts / Inserts/ Concrete embedments											
90	i	Visual check of mechanical damage and galvanising painting if applicable on inserts											
91	ii	Bolt and accessories, inserts - Dimensions (total & threaded length & dia of bolt, size & thk of embedment and lugs etc.), Nos			Visual / Measurement	100%	As per Tech Specs, Construction Drawings	SR	√	x	x	x	
92	iii	Verticality, alignment, levels, pitch distance, embeded and projected length of bolt											
93	iii	Use of template for Alignment and Level checking											
94	iv	Acceptance of foundation bolt assembly / inserts in position											
96	6	Formwork											
97	i	Materials & Accessories	As agreed/ required	Major	Visual	Once before start of work	IS :456 , Other relevant BIS Standard, Tech. Specs, Construction Drawings	SR	√	x	x	x	
98	ii	Soundness of staging, shuttering and scaffolding including application of mould oil/ release agent	As agreed/ required	Major	Visual	Once before start of work	Manufacturer's specs, IS :3096, IS:4014, IS: 4990, Tech. Specs, Construction Drawings	SR	√	x	x	x	
99	iii	Dimensional Check, alignment & levels as per drawing and tolerances		Major	Visual/ Measurement	100%	Tech. Specs, Construction Drawings	SR	√	x	x	x	
100	iv	Proper sealing of joints, Acceptance of formwork before concreting		Major	Physical/ Visual	Before start of concreting	As per provisions, tolerances, Tech. Specs, Construction drawings		√	x	x	x	
102	7	Placement of Reinforcement Steel											
103	i	Check whether Bar bending schedule (BBS) with necessary lap, spacers & chairs is available before start of cutting & bending of bars			Visual/ physical								
104	ii	Check whether cutting and bending of bars is as per BBS and placement conforms construction drawings			Visual/ measurement								
105	iii	Check whether all joints and crossing of bars are tied properly with right gauge and annealed wire	As agreed/ required	Major	Visual	Random in each shift at each work site	Tech. Specs, Construction Drawings, IS: 2502	SR	√	x	x	x	

	A	B	C	D	E	F	G	H	I	J	K	L	M
1	Sr.No.	Activity & Operation	Instruments	Class of Check	Type of Check	Quantum of Check	Reference Documents & Acceptance Standard	Format of Record	D* (Records identified with (√) shall be essentially included by EPC vender in QA documentation)	Cheking Agency			Remarks
2								SR - Site Register [*****]-SPV-QA-F-XXX[*****]-SPV-QA-T-XXX (XXX - Inspection recordform No. or Test report format no.)		M'fr/ Supplier or Sub-Contractor	EPC Contractor	[*****] or Owner	
106	iv	Check for proper cover,spacing of bars, spacers & chairs after the reinforcement cage has been put inside the foundation			Visual								
107	v	Check whether lapping of bars are tied properly with right gauge and annealedwire			Visual								
109	8	Concrete											
110	i	Availability of approved Design Mix (forall specified grades)		Critical	Physical	For each specifiedgrade of concrete	IS :456, Tech Specs, ConstructionDrawings	Approved mix design	√		x	x	The concrete shall be as per approved designmix and the materials (cement, coarse and fineaggregate shall be from the same source considered during mix trials. The mix design shall be verified and approved in case of change of source of any of the matearials
111	ii	Minimum cement content (as applicablein MMS piling and foundation/ below ground works)		Critical	Physical	For piling and foundation works	IS: 456, Tech. specs, Constructiondrawings	SR	√		x	x	The minimum cement content shall correspondto exposure conditions and/ or, sulphate contents in ground water/ soil
112	iii	Trial mixes to ascertain the workabilityand cube strength	As per recommended mix design from specialist agency	Critical	Physical/ Testing	One for each mix proportion	Tech. Specs, IS: 456	Lab Test Reports	√	x	x	x	Necessary correction for moisture content andwater absoption according to mix design recommendations may be carried out during trial mix
113	iv	Mixing of concrete- check for quanitiesof cement, CA, FA and water used, Concrete shall be homogenous	Mixing shall be done in a approved mixer/ batching plant(conforming to IS: 4926/ 4925)	Major	Physical	Mixer/ Batcher to be calibrated at the timeof starting and subsequently once intree months	IS: 4925, IS: 4926	Calibration Report/ Certificate	√	x	x	x	Review of calibration chart/ Certificate as perIS: 4926 Qty. of materials including cement consumptionshall be available through on lineprinter
114	v	Handling & trasportation	As required	Major	Physical	100%	As per approved/ agreedconstruction methodology	SR		x	x	x	Concrete shall be placed within 30 minutes of its removal from mixer
115	vi	Placement of concrete	As required	Major	Visual/ Physical	100%			√	x	x	x	
116	vii	Compacting	As required	Major	Physical	At Random			√	x	x	x	
117	viii	Curing	As required	major	Physical	At Random	IS: 456	SR		x	x	x	
119	9	Concrete Testing & Acceptance											
120	i	Workability - Slump Test		Critical	Physical	At the time of concrete pouring at site every 2 hrs	IS:456, IS:516,IS:1199, Tech Specs, Construction Drawings	Test Results /SR	√	x	x	x	
121	ii	Crushing strength - (Works test cubes)		Critical	Physical	Testing	IS:456, IS:516,IS:1199, Tech Specs, Construction Drawings	Test Results/ SR	√	x	x	x	MMS Pile - 6 cubes (3 for 7 day test & 3 for 28day strength) per sample for each 5 cum or part there off Building work and Equipment/ Misc foundations etc. - 6 cubes (3 for 7 day test &3 for 28 day strength) per sample for each 25 cum or part there off
122	iii	Acceptance of concrete work - Dimensional check (dimensions, levelsetc), placement of bolts, inserts, pockets, pitch distance for bolts etc.	As required & dimensionaltolerences	Major	Visual/ Measurement	100%		Joint Protocol between CivilContractor, EPC Vendor and [*****]/ Owner where applicable/ SR	√	x	x	x	
124	10	Acceptance of Hardened Concrete											
125	i	Dimensional check (dimensions, levelsetc), workmanship, finsishing after removal of shuttering	As required & dimensional tolerences	Major	Visual/ Measurement	At Random			√	x	x	x	

	A	B	C	D	E	F	G	H	I	J	K	L	M
1	Sr.No.	Activity & Operation	Instruments	Class of Check	Type of Check	Quantum of Check	Reference Documents & Acceptance Standard	Format of Record	D* (Records identified with (√) shall be essentially included by EPC vender in QA documentation)	Cheking Agency			Remarks
2								SR - Site Register [*****]-SPV-QA-F-XXX[*****]-SPV-QA-T-XXX (XXX - Inspection recordform No. or Test report format no.)		M'fr/ Supplier or Sub-Contractor	EPC Contractor	[*****] or Owner	
149	i	Quality & Grading of sand, Check for mix proportion, wetting the surface etc		Major	Physical	At Random	IS: 2116, IS: 2386 (Pt. I & II), IS: 1542, Tech Specs	Lab Test Results/ SR		x	x	x	Sand to be used shall be free from deleterious materials, Grading shall conform to Table-I of IS: 2116
150	ii	Plaster & grooves - Thickness, Evenness & Finishing, Trueness ospalstering system		Major	Visual/ Measurement	At Random in each shift	Tech Specifications, Construction Drawings	SR	√	x	x	x	Trueness - Deviation not more than 4mm when checked with straight edge of 2m length
151	iii	Hacking, Raking of joints, Cleaning the surface, Removing all loose particles, Wetting the surface etc		Major	Visual	At Random in each shift	IS 1661, Tech Specs	SR		x	x	x	
152	iv	Curing		Minor	Physical	100%	IS 1661, Tech Specs	SR		x	x	x	
154	14	Painting System - Plastered Masonry & Concrete surface											
155	i	Materials & accessories - Approval for Paint, Color shade and Brand-Dry distemper, Oil Bound Distemper, Acrylic Emulsion, Chemical resistant, Oil resistant Paint, Weather proof acrylic exterior paint, water proof cement paint etc.	As approved by [*****]/ Owner	Critical	Review of MTC	Each batch of delivery	Tech Specs, Construction Drawings	MTC/ SR	√	x	x	x	MTC shall be correlated with the material received
156	ii	Surface preparation	As required	Minor	Physical	Random in each shift	IS: 2935 (Pt.1), Tech Specs, Construction Drawings	SR	x	x	x	x	
157	iii	Number of coats	As required	Major	Physical	Random in each shift	Tech Specs, Construction Drawings	SR	x	x	x	x	
158	iv	Application and Acceptance of painted surface	As required	Major	Physical	Each surface at Random	Tech Specs, Construction Drawings	SR	x	x	x	x	
160	15	Floor finishes & Allied works											
161	i	Preperation of Sub-grade			Physical	At Random for each building	Tech. Specs, Construction Drawings		√	x	x	x	
162	ii	Plinth filling in layers (stone aggregates/rubble with interstices filled with sand), ramming & compaction			Physical	At Random for each building	IS: 2720, Tech. Specs, Construction Drawings	SR	√	x	x	x	Quality Checks as aplicable to Fill/ Back fill
163	iii	Check providing shuttering, reinforcement (if applicable)			Physical	At Random for each building	Tech. Specs, Construcion Drawings			x	x	x	Quality Checks as aplicable to Shuttering/Reinforcement placement
164	iv	Checking the Panel size (as applicable)			Physical	At Random for each building	IS: 5491, Tech. Specs, Construcion Drawings			x	x	x	The concrete shall be cast in alternate panels in chess board fashion, panel size as specified in Construction Drawing or 25 sqm
165	v	Availability of Design mix (if applicable)			Visual	At Random for each building	Tech. Specs, Construcion Drawings	Mix Design Report/ SR		x	x	x	
166	vi	Clearance for concreting (as applicable)			Physical	100%	Tech. Specs, Construction Drawings	Joint Protocol between Civil Contractor, Eqpt. Supplier/EPC Vendor & [*****]/ Owner SR		x	x	x	
167	viii	Performing concreting ensuring Grade/Mix Proportions, Compaction, Thickness and Finish			Physical	At Random per shift	IS; 456, Tech. Specs, Construction Drawings	SR	√	x	x	x	Quality Checks as aplicabel to Concrete Work
168	viii	Curing			Visual	100%	IS: 456, Tech. Specs	SR		x	x	x	Minimum up to 10 days from date of casting

	A	B	C	D	E	F	G	H	I	J	K	L	M
1	Sr.No.	Activity & Operation	Instruments	Class of Check	Type of Check	Quantum of Check	Reference Documents & Acceptance Standard	Format of Record	D* (Records identified with (√) shall be essentially included by EPC vender in QA documentation)	Cheking Agency			Remarks
2								SR - Site Register [*****]-SPV-QA-F-XXX[*****]-SPV-QA-T-XXX (XXX - Inspection recordform No. or Test report format no.)		M'fr/ Supplier or Sub-Contractor	EPC Contractor	[*****] or Owner	
223	i	Door Frame (Hollow steel metal, Aluminium, Wooden etc. including fittings such as hold fasts etc.)	As agreed/ required	Critical	Visual, Physical, Review of MTC/ Test Reports	Each lot received at site	Tech. Specs and Construction Drawings	MTC/ Lab Test Reports/SR	√	x	x	x	
224	a	Steel Doors											
225	i	Materials (MS sheet & Stiffeners, fasteners, hinges, jambs, lock strike plate, hydraulic door closer, fittings and fixtures etc)	As agreed/ required	Critical	Visual/ Physical/ Review of MTC, Test Report	Each lot received at site	IS:2062, Tech. Specs and Construction Drawings	MTC/ Lab Test Report/SR	√	x	x	x	Review of MTC/ Test Report
226	ii	Finishing & Acceptance - Surface preparation for painting, primer & finishing coat, DFT	As agreed/ required	Major	Visual/ Physical	Random	Tech. Specs and Construction Drawings	SR	√	x	x	x	
227	b	Flush Doors											
228	i	Shutters, Teak beading	As agreed/ required	Critical	Review of MTC/Test Report	Each lot received at site	IS:2202, Tech. Specs and Construction Drawings	MTC/ Lab Test Report/SR	√	x	x	x	
229	ii	Acceptance	As agreed/ required	Major	Visual/ Physical	Random	Tech. Specs and Construction Drawings	SR		x	x	x	
230	c	Aluminium doors and Partition works											
231	i	Materials- Aluminium sections (average thickness, alkali resistant, anodisation, power coating and colour shade etc.), fittings and fixtures. floor spring, hydraulic door closer, hinges, etc.	As agreed/ required	Critical	Visual/ Physical/ Review of Test Report	Each lot received at site	IS:1948, IS:1949, IS:733, IS:1285, IS:1868, IS:11857, Tech. Specs and Construction Drawings	SR/ Lab Test Reports	√	x	x	x	Review of Test Report For anodization check as per Tech. Specs and Construction Drawings Power coating, colour shade as applicable as per Tech. Specs and Construction Drawings
232	ii	Finishing & Acceptance - fabrication & erection, fitting etc..	As agreed/ required	Major	Visual/ Physical	Random	Tech. Specs and Construction Drawings	SR		x	x	x	
233	d	Grill											
234	i	Materials - Aluminium, MS, Anodization in case of aluminium	As agreed/ required	Critical	Visual/Physical/ Review of Test Report	Each lot received at site	Tech. Specs and Construction Drawings	SR/ Lab Test Reports	√	x	x	x	Review of Test Reports
235	ii	Finishing & Acceptance - erection, fitting, painting in case of MS grill etc.	As agreed/ required	Major	Visual/ Physical	Random	Tech. Specs and Construction Drawings	SR		x	x	x	
236	e	Rolling Shutters											
237	i	Surface finish, Thickness of plate, mechanically operated	As agreed/ required	Critical	Visual/ Physical/ review of MTC	Random for each lot of delivery	IS:8248, Tech. Specs & Construction Drawings	SR	√	x	x	x	
238	ii	Finishing and Acceptance - Painting, DFT	As agreed/ required	Major	Visual/ Physical	Random	Tech. Specs and Construction Drawings	SR		x	x	x	
239	f	Glass and Glazing											
240	i	Material - Clear float glass, wired glass, tinted glass, ground glass, figured glass, thickness	As agreed/ required	Major	Review of MTC/test reports	For each lot received at site	IS: 14900, IS:1081, IS: 3548, IS:5437 Tech Specs and Construction Drawings	SR	√	x	x	x	
241	ii	Installation, finishing and acceptance	As agreed/ required	Major	Visual/ Physical	Random	Tech Specs and Construction Drawings	SR	√	x	x	x	
243	23	Precast Concrete Boundary Wall											
244		Acceptance of boundary wall- Finishing, Alignment Dimensions etc.	As agreed/ required	Major	Physical		Tech Specs and Construction	SR		x	x	x	For inspection of precast concrete units - refer S.No. 18

269	i	HDPE pipes and fittings/ joints	As agreed/ required	Critical	Review of MTC/test reports		IS:4984, Tech. Specs	MTC/SR	√	x	x	x	
270	ii	Acceptance & leakage	As agreed / required	Major	Physical	Random	Tech Specs and Const. Drawings	SR		x	x	x	
271	e	Sanitary fitting and fixtures											
272	i	Sanitary items and fixtures i.e. water closets, urinals, wash basins, sinks, mirrors, shelves, towel rail, soap containers, geyser, water cooler, etc, water supply / sanitation pipes, manholecover and frames etc	As agreed / required	Major	Review of MTC/Test reports	Each lot of delivery as per Specifications	Tech Specs and Const. Drawings	MTC/Test Reports/SR	√	x	x	x	

	A	B	C	D	E	F	G	H	I	J	K	L	M
1	Sr.No.	Activity & Operation	Instruments	Class of Check	Type of Check	Quantum of Check	Reference Documents & Acceptance Standard	Format of Record	D* (Records identified with (√) shall be essentially included by EPC vender in QA documentation)	Cheking Agency			Remarks
2								SR - Site Register [*****]-SPV-QA-F-XXX[*****]-SPV-QA-T-XXX (XXX - Inspection recordform No. or Test report format no.)		M'fr/ Supplier or Sub-Contractor	EPC Contractor	[*****] or Owner	
273	ii	Acceptance of installations of allsanitary items and fixtures	As agreed / required	Major	Acceptance	100%	Tech Specs and Const. Drawings	SR		x	x	x	
274	f	RCC Pipes											
275	i	Material - RCC pipes	As agreed / required	Major	Review of MTC/test reports	Each lot of delivery as per Specifications	IS: 458, Tech Specs and Const. Drawings	MTC/Test Reports/SR	√	x	x	x	
276	ii	Acceptance and leakage	As agreed / required	Major	Physical	Random	Tech Specs and Const. Drawings	SR		x	x	x	
277	g	Water Storage Tank											
278	i	Over head / loft type	As agreed / required	Critical	Physical, reviewof MTC/ test reports	Each lot of delivery as per Specifications	IS:12701, Tech Specs and Const. Drawings	MTC/Test Reports/SR	√	x	x	x	
279	ii	Acceptance and leakage	As agreed / required	Major	Acceptance	Random	IS:12701, Tech Specs and Const. Drawings	SR		x	x	x	
281	26	Special Items (Switch Yard)											
282	a	Earthing Mat (Grounding System)											
283	i	Earthing mat	As agreed / required	Critical	Physical, reviewof MTC/ test reports	Each lot of delivery as per Specifications	As per relevant IS and Tech. Specs / Manufacturer's, IS 3043	SR/MTC	√	x	x	x	
284	ii	Weld sizes & length	Visual/Tape	Major	Visual/ Measurement	100%	Tech Specs and Const. Drawings	SR		x	x	x	Low hydrogen electrode as per approval shallbe used.
285	iii	D P test	DP test Kit	Critical	Physical	10% at random	Tech Specs and Const. Drawings	TR	√	x	x	x	
286	iv	Earth test	Earthing test kit	Critical	Physical	100%	IS:3043, Tech Specs and Const. Drawings, Relevant IS 3043	SR/ Test Report	√	x	x	x	
287	b	Anti Weed Treatment											
288	i	Anti-weed treatment materials	As agreed / required	Critical	Physical, reviewof MTC	Each batch of delivery	Tech Specs and Const. Drawings	SR/ MTC	√	x	x	x	
289	ii	Execution of treatment	As agreed / required	Major	Physical	Random check foreach treatment	Tech Specs and Const. Drawings	SR		x	x	x	
291	27	Road Work											
292	a	Construction of Sub-Grade and earthen/hard soulders											
293	i	Standard proctor Test	As per IS: 2720	Critical	Physical	One in every 2000 cum for each type and source of fill materials	As per Tech Specs and Const. Drawings, Section 900 of MORTHspecification, IS 2720 (Pt.VII)	SR	√	x	x	x	In cutting or existing levelled ground - quantumof check shall be one per 1000 SQM
294	ii	Moisture content of fill beforecompaction	As per IS: 2720	Major	Physical	One in every 2000 cum for each type and source of fill materials	As per Tech Specs and Const. Drawings, Section 900 of MORTHspecification, IS 2720 (Pt.II)	SR		x	x	x	In cutting or existing levelled ground - quantumof check shall be one per 1000 SQM
295	iii	Dry density by core cutter method ---- OR---- Dry density in place by sanddisplacement method	As per IS: 2720	Critical	Physical	One in every 500 SQM area for each compacted layer.	As per Tech Specs and Const. Drawings, Section 900 of MORTHspecification, IS 2720 (Pt. XXIX)/ IS 2720 (Pt. XXVIII)	SR	√	x	x	x	Both for embankment and cut formation quantum of check - One in every 1000 SQMarea for each compacted layer.

296	iv	Lines, grade and cross section	As required / agreed	Major	Physical	One in every 500SQM area	As per Tech Specs and Const.Drawings	SR	√	x	x	x	Template, straight edge
-----	----	--------------------------------	----------------------	-------	----------	--------------------------	--------------------------------------	----	---	---	---	---	-------------------------

	A	B	C	D	E	F	G	H	I	J	K	L	M
	Sr.No.	Activity & Operation	Instruments	Class of Check	Type of Check	Quantum of Check	Reference Documents & Acceptance Standard	Format of Record	D* (Records identified with (√) shall be essentially included by EPC vender in QA documentation)	Cheking Agency			Remarks
										M'fr/ Supplier or Sub-Contractor	EPC Contractor	[*****] or Owner	
1													
2								SR - Site Register [*****]-SPV-QA-F-XXX[*****]-SPV-QA-T-XXX (XXX - Inspection recordform No. or Test report format no.)					
297	b	Water Bound Macadam (Non-Bituminous) for base course and sub-base course											
298	i	Aggregate Impact value	Aggregate Impact value Test Apparatus	Critical	Physical	One test per 200 cum of Test aggregate	As per Tech Specs and Const. Drawings, Section 900 of MORTH specification	SR	√	x	x	x	
299	ii	Grading	Set of IS Sieves	Major	Physical	One test per 100 cum of aggregate	As per Tech Specs and Const. Drawings, Section 900 of MORTH specification	SR		x	x	x	
300	iii	Flakiness index and elongation index	Flakiness test gauge	Major	Physical	One test per 200 cum of aggregate	As per Tech Specs and Const. Drawings, Section 900 of MORTH specification	SR		x	x	x	
301	iv	Atterberg Limits of binding material	Atterberg limits determination	Critical	Physical	One test per 25 cum of binding material	As per Tech Specs and Const. Drawings, Section 900 of MORTH specification	SR	√	x	x	x	
302	v	Atterberg Limits of portion of aggregate passing 425 micron sieve	Atterberg limits determination	Critical	Physical	One test per 100 cum of aggregate	As per Tech Specs and Const. Drawings, Section 900 of MORTH specification	SR	√	x	x	x	
303	vi	Camber, surface, slope	As required / agreed	Major	Physical	One in every 500 SQM area	As per Tech Specs and Const. Drawings	SR	√	x	x	x	Template, straight edge
304	c	Bituminous Macadam for base and binder course											
305	i	Quality of binder	Penetrometre with St. needle	Critical	Physical	No. of samples per Lot & tests as per IS:73, IS:217, IS:8887 as applicable	As per Tech Specs and Const. Drawings, Section 900 of MORTH specification, IS 73	SR	√	x	x	x	
306	ii	Aggregate Impact Value / Los angeles abrasion value	Aggregate Impact Value Test apparatus	Major	Physical	Once per source	As per Tech Specs and Const. Drawings, Section 900 of MORTH specification	SR	√	x	x	x	
307	iii	Flakiness Index and elongation index of aggregates	Flakiness test gauge	Major	Physical	One test per 50 cum of aggregate	As per Tech Specs and Const. Drawings, Section 900 of MORTH specification	SR		x	x	x	
308	iv	Stripping value of aggregate (Immersion tray test)	As required / agreed	Major	Physical	Initially one set of 3 representative specimen per source, and on every change of source.	As per Tech Specs and Const. Drawings, Section 900 of MORTH specification	SR		x	x	x	
309	v	Water sensitivity of mix	As required / agreed	Critical	Physical	Initially one set of 3 representative specimen per source, and on every change of source.	As per Tech Specs and Const. Drawings, Section 900 of MORTH specification	SR	√	x	x	x	
310	vi	Grading of aggregates	Set of Sieves	Major	Physical	Two test per day per plant both on individual constituents and mixed aggregate from dryer	As per Tech Specs and Const. Drawings, Section 900 of MOSRTH specification	SR		x	x	x	
311	vii	Water absorption of aggregate	As required / agreed	Major		Initially one set of 3 representative specimen per source, and on every change of source.	As per Tech Specs and Const. Drawings, Section 900 of MOSRTH specification	SR		x	x	x	

	A	B	C	D	E	F	G	H	I	J	K	L	M
1	Sr.No.	Activity & Operation	Instruments	Class of Check	Type of Check	Quantum of Check	Reference Documents & Acceptance Standard	Format of Record	D* (Records identified with (√) shall be essentially included by EPC vender in QA documentation)	Cheking Agency			Remarks
2								SR - Site Register [*****]-SPV-QA-F-XXX[*****]-SPV-QA-T-XXX (XXX - Inspection recordform No. or Test report format no.)		M'fr/ Supplier or Sub-Contractor	EPC Contractor	[*****] or Owner	
312	viii	Soundness (Magnesium and Sodium Sulphate)	As required as per IS:2386	Critical	Physical	Once per source by each method and on every change of source	As per Tech Specs and Const. Drawings, Section 900 of MOSRTH specification	SR	√	x	x	x	
313	ix	Percentage of fractured faces	As required / agreed	Major	Physical	When gravel is used one test per 50cum of aggregates	As per Tech Specs and Const. Drawings, Section 900 of MOSRTH specification	SR		x	x	x	
314	x	Binder content and aggregate grading	Bitumen extractor	Critical	Physical	Periodic, subject to amin of two tests per day per plant	As per Tech Specs and Const. Drawings, Section 900 of MORTHspecification	SR	√	x	x	x	
315	xi	Control of Temperature of binder and aggregate for mixing and of the mix at the time of laying and rolling	Thermometer	Major	Physical	At regular close intervals	As per Tech Specs and Const. Drawings, Section 900 of MORTHspecification	SR		x	x	x	
316	xii	Rate of spread of mixed materials	As required / agreed	Major	Physical	Regular control through checks of layer thickness	As per Tech Specs and Const. Drawings, Section 900 of MORTHspecification	SR		x	x	x	
317	xii	Density of compacted Layer	As required / agreed	Critical	Physical	One test per 250 sqm of area	As per Tech Specs and Const. Drawings, Section 900 of MORTHspecification	SR	√	x	x	x	
318	c	Bituminous Surfacing - Open graded premix carpet and Seal coat											
319	i	Quality of binder	Penetrometre with St. needle	Critical	Physical	No. of samples per Lot & tests as per IS:73, IS:217, IS:8887 as applicable	IS 73, Tech Specs and Const. Drawings, Section 900 of MORTHspecification	SR	√	x	x	x	
320	ii	Aggregate Impact Value / Los angeles abrasion value	Aggregate Impact Value Test apparatus	Major	Physical	One test per 50 cum of aggregate	As per Tech Specs and Const. Drawings, Section 900 of MORTHspecification	SR	√	x	x	x	
321	iii	Flakiness Index and elongation index of aggregates	Flakiness test gauge	Major	Physical	One test per 50 cum of aggregate	As per Tech Specs and Const. Drawings, Section 900 of MORTHspecification	SR		x	x	x	
322	iv	Stripping value of aggregate (Immersion tray test)	As required / agreed	Major	Physical	Initially one set of 3 representative specimen per source, and on every change of source.	As per Tech Specs and Const. Drawings, Section 900 of MORTHspecification	SR	√	x	x	x	
323	v	Water absorption test		Critical	Physical	Initially one set of 3 representative specimen per source, and on every change of source.	As per Tech Specs and Const. Drawings, Section 900 of MORTHspecification	SR	√	x	x	x	
324	vi	Water sensitivity of mix	As required / agreed	Critical	Physical	Initially one set of 3 representative specimen per source, and on every change of source.	As per Tech Specs and Const. Drawings, Section 900 of MORTHspecification	SR	√	x	x	x	
325	vii	Grading of aggregates	Set of Sieves	Major	Physical	One test per 25 cum of aggregates	As per Tech Specs and Const. Drawings, Section 900 of MORTHspecification	SR	√	x	x	x	

	A	B	C	D	E	F	G	H	I	J	K	L	M
1	Sr.No.	Activity & Operation	Instruments	Class of Check	Type of Check	Quantum of Check	Reference Documents & Acceptance Standard	Format of Record	D* (Records identified with (√) shall be essentially included by EPC vender in QA documentation)	Cheking Agency			Remarks
2								SR - Site Register [*****]-SPV-QA-F-XXX[*****]-SPV-QA-T-XXX (XXX - Inspection recordform No. or Test report format no.)		M'fr/ Supplier or Sub-Contractor	EPC Contractor	[*****] or Owner	
326	viii	Soundness (Magnesium and Sodium Sulphate)	As required as per IS:2386	Critical	Physical	Once per source by each method and one every change of source	As per Tech Specs and Const. Drawings, Section 900 of MORTH specification	SR	√	x	x	x	
327	ix	Polished stone value	As required as per BS:812(Part114)	Major	Physical	As required	As per Tech Specs and Const. Drawings, Section 900 of MORTH specification	SR		x	x	x	
328	x	Temperature of binder at application	Thermometer	Major	Physical	At regular close intervals	As per Tech Specs and Const. Drawings, Section 900 of MORTH specification	SR		x	x	x	
329	xi	Binder content	Bitumen extractor	Critical	Physical	One test per 500 cum & not less than two tests per day	As per Tech Specs and Const. Drawings, Section 900 of MORTH specification	SR	√	x	x	x	
330	xii	Rate of spread of materials	As required / agreed	Major	Physical	One test per 500 cum and not less than 2 tests per day	As per Tech Specs and Const. Drawings, Section 900 of MORTH specification	SR		x	x	x	
331	xiii	Percentage of fractured faces	Bitumen extractor	Critical	Physical	When gravel is used one test per 50 cum of aggregates	As per Tech Specs and Const. Drawings, Section 900 of MORTH specification	SR	√	x	x	x	
332	d	Tack Coat/ Prime coat/ fog coat											
333	i	Quality of binder	Penetrometre with Standard needle	Critical	Physical	No. of samples per Lot & tests as per IS:73, IS:217, IS:8887 as applicable	IS 73, Tech Specs and Const. Drawings, Section 900 of MORTH specification	SR	√	x	x	x	
334	ii	Temperature of binder at application	Thermometer	Major	Physical	At regular close intervals	As per Tech Specs and Const. Drawings, Section 900 of MORTH specification	SR		x	x	x	
335	iii	Rate of spread of binder	As required / agreed	Major	Physical	One test per 500 cum and not less than 2 tests per day	As per Tech Specs and Const. Drawings, Section 900 of MORTH specification	SR		x	x	x	
336	e	Alignment, Level, Surface regularity and rectification											
337	i	Horizontal alignment, Surface levels and Surface regularity	As required / agreed	Major	Physical	At Random	As per Tech Specs and Const. Drawings, Section 900 of MORTH specification	SR	√	x	x	x	
338	ii	Rectification	As required / agreed	Major	Physical	Each rectification	As per Tech Specs and Const. Drawings, Section 900 of MORTH specification	SR		x	x	x	
340	28	Geotechnical Investigations											
341	i	Deployment of approved Geotechnical Investigation Agency - Equipments, Manpower etc	As required / agreed	Critical	Physical	Once before commencement of work	As per technical specifications and relevant IS Codes	SR	√	x	x	x	
342	ii	Execution of Geotechnical Investigation - locations, type etc as per scheme	As required / agreed	Major	Physical	Each Location	As per technical specifications and relevant IS Codes	SR		x	x	x	
343	iii	Collection of disturbed and undisturbed samples, their packing and storage	As required / agreed	Major	Physical	each sampling	As per technical specifications and relevant IS Codes	SR		x	x	x	
344	iv	Conducting field tests as per investigation scheme- such as, SPT/ERT/SCPT/PLT/PMT etc	As required / agreed	Major	Physical	each field test	As per technical specifications and relevant IS Codes	SR		x	x	x	

	A	B	C	D	E	F	G	H	I	J	K	L	M
	Sr.No.	Activity & Operation	Instruments	Class of Check	Type of Check	Quantum of Check	Reference Documents & Acceptance Standard	Format of Record	D* (Records identified with (√) shall be essentially included by EPC vender in QA documentation)	Cheking Agency			Remarks
										M'fr/ Supplier or Sub-Contractor	EPC Contractor	[*****] or Owner	
1													
2								SR - Site Register [*****]-SPV-QA-F-XXX[*****]-SPV-QA-T-XXX (XXX - Inspection recordform No. or Test report format no.)					
345	v	Submission of Field Borelogs inapproved format	As required / agreed	Major	Review	Within 24 hours aftercompletion of each BH	As per technical specifications andrelevant IS Codes	SR		x	x	x	
346	vi	Submission of laboratory test schedule and selection of samples for laboratory testing	As required / agreed	Critical	Review and acceptanc e	as per consultation with engineer during dispatch of samplesto approved laboratory	As per technical specifications andrelevant IS Codes	SR	√	x	x	x	
347	vii	Submission of Final Geotechnical investigation report along with recommendations	As required / agreed	Critical	Physical	After completion ofinvestigation work and review of draftreports	As per technical specifications andrelevant IS Codes	SR		x	x	x	
349	29	Topographical Survey Works											
350	i	Deployment of approved Topographical Surveying Agency - Equipments, Manpower etc	As required / agreed	Critical	Physical	Once before commencement ofwork	As per technical specifications andrelevant IS Codes	SR	√	x	x	x	
351	ii	Transfer of Permanent Bench mark tosite from known location	As required / agreed	Major	Physical	Before commencement ofwork	As per technical specifications andrelevant IS Codes	SR		x	x	x	
352	iii	Establishment of boundary pillars andsurvey grid, Temporary bench Marks, Measurement & recording spot levels	As required / agreed	Major	Physical		As per technical specifications andrelevant IS Codes	SR		x	x	x	
353	iv	Recording features like trees, roads,transmission lines, lake, nala, river, temple, house, culverts etc. with coordinate locations	As required / agreed	Major	Physical		As per technical specifications andrelevant IS Codes	SR		x	x	x	
354	vi	Submission of final Counter map showing all topographical features,record of spot levels	As required / agreed	Critical	Physical	After completion ofinvestigation work and review of draftreports	As per technical specifications andrelevant IS Codes	SR	√	x	x	x	
356	30	Internal Switchyard - Site Leveling & Grading											
357	i	Leveling Switchyard area	As required / agreed	Major	Visual / Physical	100%	As perTech. Specification andApproved Drawing	SR		x	x	x	
358	ii	Grading of 20/40mm stone / GravelSpreading in sitchyard area	As required / agreed	Major	Physical	100%	As per Tech. Specification &Approved Drawing	SR		x	x	x	
360	31	Plant Boundary Fencing (if applicable) & Gate (Also refer S.No. 3 for Steel works as applicable)											
361	i	Fence posts (Intermediate, Stay & Corner Posts etc.) - Section size,Length, Galvanization - Grade/ Thickness, Tensile strength etc.	As agreed/ Required	Critical	Physical/ Measurement/ Review of MTC	Each lot received at site Random	IS:226; IS:2721; IS:278; IS:480; IS:4826 , Tech. Specs & Construction Drawings	MTC/ SR	√	x	x	x	For Structural steel checks refer S.No. 3
362	ii	Barbed wire - Dia. of line wire and barbwire, Grade of galvanization etc, Tensilestrength etc.	As agreed/ Required	Critical	Physical/ Measurement/ Review of MTC		√		x	x	x		
363	iii	Tie wire - Diameter, Galvanization-Grade, tensile strength etc.	As agreed/ Required	Critical	Physical/ Measurement/		√		x	x	x		

364	iv	Blade barbed/ Concertina Wire - Thickness/ Diameter, galvanization, Diameter of concertina coil, Tensile strength etc.	As agreed/ Required	Critical	Physical/ Measurement/ Review of MTC				√	x	x	x
-----	----	--	---------------------	----------	--------------------------------------	--	--	--	---	---	---	---

A	B	C	D	E	F	G	H	I	J	K	L	M	
Sr.No.	Activity & Operation	Instruments	Class of Check	Type of Check	Quantum of Check	Reference Documents & Acceptance Standard	Format of Record	D* (Records identified with (√) shall be essentially included by EPC vender in QA documentation)	Cheking Agency			Remarks	
									M'fr/ Supplier or Sub-Contractor	EPC Contractor	[****] or Owner		
365	v	Fence Fabric- Mesh size, Wire Diameter, Galvanization-Grade, Selvage, Knuckling, Tensile strength etc.	As agreed/ Required	Critical	Physical/ Measurement/ Review of MTC			√	x	x	x		
366	vi	MS Gate - Caster weels, ball & bearings, Fixtures & fasteners etc.	As agreed/ Required	Major	Visual	100%	Tech. Specs & Construction Drawings	SR	x	x	x		
367	vi	Acceptance of Boundary Fence and gate	As agreed/ Required	Major	Physical	100%	Tech. Specs & Construction Drawings	SR	x	x	x		
369	32	Tranformer Yard Fencing & Gate (Also refer S.No. 3 for Steel Works as applicable)											
370	i	Fence posts (Intermediate, Stay & Corner Posts), Concertina Wire SupportAngles - Section size, Length, Galvanization, Tensile strength etc.	As agreed/ Required	Critical	Physical/ Measurement/ Review of MTC	Each lot received at site Random	IS-226; IS 2721; IS-4948 , IS:480;IS:4826 Tech. Specification and Approved Drawing	√	x	x	x	For structural steel checks refer S.No. 3	
371	ii	Tie wire (as aplicable) - Diameter, Galvanization, Tensile strength etc.	As agreed/ Required	Critical	Physical/ Measurement/ Review of MTC		MTC/ SR	√	x	x	x		
372	iii	Fence Fabric (chain link/ welded wire as aplicable)- Mesh size, Wire Diameter, Galvanization, Selvage, Knuckling, Tensile strength etc.	As agreed/ Required	Critical	Physical/ Measurement/ Review of MTC			√	x	x	x		
373	iv	MS Gate - Fixtures and fasteners	As agreed/ Required	Major	Visual	100%	Tech Specs and Approved Drawings	SR	x	x	x		
374	v	Acceptance of Fence & Gate	As agreed/ Required	Major	Physical	100%	Tech Specs and Approved Drawings	SR	x	x	x		
376	33	Installation of Pre Engineered Building (PEB) - Security Cabin											
377	a	Receipt											
378	i	Receipt of materials and Checking as per packing list	As agreed/ Required	Major	Visual	100%	As per Approved Drawings & Method Statement, Relevant BISstandards	√	x	x	x		
379	iii	Dimensional Check	As agreed/ Required	Major	Measurement	100%		√	x	x	x		
380	iv	Visual checks for damages, rusting, pitting etc.	As agreed/ Required	Major	Visual	100%			x	x	x		
381	v	Visual checks for defects, primer coating and painting/galvanising as applicable.	As agreed/ Required	Major	Visual	100%			x	x	x		
382	vi	Nut/Bolt/Washers Checks	As agreed/ Required	Major	Visual	100%			x	x	x		
383	b	Pre-Installation											
384	i	Check that the work area is ready and safe to start installation	As agreed/ Required	Major	Visual / Dimension			SR		x	x		x
385	ii	Check readiness of Foundations	As agreed/ Required	Major		100%				x	x		x
386	c	Installation (as aplicable)											
387	i	Readyness of concrete platform, foundations for installation- Size, Location, Level etc.	As agreed/ Required	Major	Visual					x	x		x
388	ii	Check PUF side walls/ roof are installed properly	As agreed/ Required	Major	Physical				x	x	x		
389	iii	Check tightening of all Nut/Washers/Bolts	As agreed/ Required	Major	Physical				x	x	x		

391	34	Structural Work for Module Mounting Structure (MMS)					Tech. Specification, Approved Drawing & Method Statement						
437	a	Manufacturing											

	A	B	C	D	E	F	G	H	I	J	K	L	M
1	Sr.No.	Activity & Operation	Instruments	Class of Check	Type of Check	Quantum of Check	Reference Documents & Acceptance Standard	Format of Record	D* (Records identified with (√) shall be essentially included by EPC vender in QA documentation)	Cheking Agency			Remarks
2								SR - Site Register [****]-SPV-QA-F-XXX[****]-SPV-QA-T-XXX (XXX - Inspection recordform No. or Test report format no.)		M'fr/ Supplier or Sub-Contractor	EPC Contractor	[****] or Owner	
438		Structural Steel (Raw Material) Hot rolled & cold formed sections - Angle, Channel, Z-section, Box section, Plate, rod & bar											
439	i	Ultimate Tensile Strength (UTS), Yield Strength (YS), Percentage Elongation, Bend Test, Chemical Composition, Section dimensions	As agreed/ Required	Critical	Chemical composition, Mechanical, Measurement	1 Sample per 50 MT or part thereof/ for every heat no.	IS 2062, IS 513, IS 811, IS 1079, IS 808, IS 1852, IS 1730 -Part I	MTC	√				Raw material to be procured from reputed manufacturers - like SAIL, RINL, JSPL, JSW, TISCO, ISSAR
440	ii	Visual Examination - Cracks, Scaling, Rust, Pitting, Lamination etc.	As agreed/ Required	Major	Visual	10% IS 2500, Level II, AQL 1.5	IS 2062, IS 513, IS 811, IS 1079, IS 808, IS 1852, IS 1730-Part I	SR	√	x	x	x	Material shall be free from surface defects like cracks, lamination, roughness, imperfect edges, rust, pitting & other harmful defects. Removal of minor surface defects as per IS:2062 is acceptable. Witness for 10% sample. Record review for every material
441		Boughtout Items (Hardware - Nuts, Bolts and Washers - plain, spring)											
442	i	Mechanical & Chemical Properties	As agreed/ Required	Critical	Chemical composition, Mechanical	1 sample per 5 MT or part thereof	IS 1327 (Part 17) eq./ ASTM standard	MTC/ Lab test Report	√	x	x	x	
443	ii	Dimensional check (Dia., Thickness, Total stem length & Threaded length etc.)	As agreed/ Required	Major	Measurement	IS 1327 (part 17) eq 10 pieces per lot per member type	IS 6639, IS 2016, IS 6610 & IS 3063 / ASTM standard	Vendor Records	√	x	x	x	Witness for sample. Record review for every material
444	iii	Galvanizing - Mass per Sqm, Thickness (DFT)	As agreed/ Required Alcometer	Major	Visual, Measurement	IS 1327 (part 17) eq 10 pieces per lot per member type	For Hot dip galvanizing should be maintained 43 microns (min) and average 54 microns as per IS 1367 (part XIII) eq.	Vendor Records	√	x	x	x	Record review Random sample inspection/ measurement
445	b	In Process Inspection											
446		Structural Item Fabrication											
447	i	Straightening	As agreed/ Required	Major	Visual	100%	0.2% of total length	Vendor Records	√	x	x	x	Record review
448	ii	Cropping (Cutting)	As agreed/ Required	Major	Visual	100%	Approved drawing	Vendor Records	√	x	x	x	Record review
449	iii	Identification/ Marking	As agreed/ Required	Major	Visual	100%	Approved drawing Marking Shall be done with the help of permanent paint marker using stencil as per Drawing	Vendor Records	√	x	x	x	Record review Random sample inspection
450	iv	Punching/ Drilling of Holes	As agreed/ Required	Critical	Measurement	1 piece per 25 pieces	IS 802/ Approved drawing	Vendor Records	√	x	x	x	Record review
451		Edge Security							√	x	x	x	
452	v	Overall Length	As agreed/ Required	Major	Measurement	1 piece per 25 pieces	IS 802/ Approved drawing	Vendor Records	√	x	x	x	Record review Random sample measurement
453	vi	Bending	As agreed/ Required	Critical	Measurement	100%	IS 801, 811/ Approved drawing	Vendor Records	√	x	x	x	Record review
454		Cross Section Dimensions							√	x	x	x	Record review
455	vii	Welding	As agreed/ Required	Major	Visual	100%	Approved Welding Procedure & Welder Qualification	Vendor Records	√	x	x	x	Record review Random sample inspection

494	i	Check for foundation readiness - location & coordinates, dimensions & levels, foundation bolts etc.		Major	Physical	100%				x	x	x		
496	37	Inverter Panel					Design Specification, Drawings, Manufacturer Manual Method Statement	SR						
497		Pre Installation												
498	i	Check for site physical layout as per drawing.		Major	Visual	100%				√	x	x	x	
499	ii	Ensure that no fouling with civil/structural		Major	Physical	Random					x	x	x	
500	iii	Check for Foundation readiness and level of foundation.		Major	Physical	100%				x	x	x		
502	38	Burried Cables					Design Specification, Drawings, Manufacturer Catalogue Method Statement (SW-SEPC-MS-CAB-006)							
503	i	Cable Trench - Dimensions, alignment		Critical	Physical	100%	Design Specification, Drawings, Manufacturer Catalogue Method Statement	SR		x	x	x		
504	ii	Sand filling before cable laying, sandfilling after cable laying, placing of precast concrete slabs/ bricks, backfilling with soil		Major	Visual	100%					x	x	x	

	A	B	C	D	E	F	G	H	I	J	K	L	M	
	Sr.No.	Activity & Operation	Instruments	Class of Check	Type of Check	Quantum of Check	Reference Documents & Acceptance Standard	Format of Record	D* (Records identified with (√) shall be essentially included by EPC vendor in QA documentation)	Cheking Agency			Remarks	
1										M'fr/ Supplier or Sub-Contractor	EPC Contractor	[****] or Owner		
2								SR - Site Register [****]-SPV-QA-F-XXX[****]-SPV-QA-T-XXX (XXX - Inspection record form No. or Test report format no.)						
592			LEGEND: D* Records, indentified with "Tick" (√) shall be essentially included by supplier in QA documentation.								DOC. NO.: [****] - XXX - XXX -XXX - FQP & MQP - 001 REV: 0			
593			Legend to be used:											
594			Class # : A = Critical, B=Major, C=Minor											
595			Format of Record # : SR=Site Register, TR=Lab Test Report, IR=Inspection Report, MTC=Manufacturer's Test Certificate											
596			All MTC's shall be correlated with batch of material supply, Tech specs and drawings											
597			Category 'A' - Sub-contractor/ sub-vendor, EPC Vendor, [****]/ Owner											
598			Category 'B' - Sub-Contractor/ Sub-Vendor, EPC Vendor, [****]											
599			Category 'C' - Sub-Contractor/ Sub-Vendor											
600														
601			This document shall be read in conjunction with Tech. Specifications and Drawings								Reviewed By	Approved By	Approval Seal	



Bharat Coking Coal Limited

Tender for Design, Engineering, Procurement & Supply, Construction & Erection, Testing, Commissioning, Associated Transmission System and Comprehensive O&M for 5 (Five) Years of 20 MW (AC)/28 MWp (DC) Solar PV Power Plant and connecting Transmission lines at Dugdha Washery, BCCL- Dhanbad



Annexure – C

PG Test Procedure

**20 MW (AC) Solar PV Power
Plant at Dugdha, BCCL-
Dhanbad, Jharkhand**

Tender No.

.....

168 | Page



Bharat Coking Coal Limited

Tender for Design, Engineering, Procurement & Supply, Construction & Erection, Testing, Commissioning, Associated Transmission System and Comprehensive O&M for 5 (Five) Years of 20 MW (AC)/28 MWp (DC) Solar PV Power Plant and connecting Transmission lines at Dugdha Washery, BCCL- Dhanbad



CNUL

TABLE OF CONTENTS

1 INTRODUCTION 169

2 FUNCTIONAL GUARANTEE TESTS FOR SOLAR PV PLANT 169

2.1 PERFORMANCE RATIO GUARANTEE TEST 169

2.2 PRE-PR TEST 171

2.3 PR TEST PROCEDURE 171

2.4 CAPACITY UTILIZATION FACTOR (CUF) 175

2.5 LIQUIDATED DAMAGES FOR SHORTFALL IN PR 179

2.6 LIQUIDATED DAMAGES FOR SHORTFALL IN CUF 179

2.7 INCENTIVES FOR EXCESS CUF 179



Bharat Coking Coal Limited

Tender for Design, Engineering, Procurement & Supply, Construction & Erection, Testing, Commissioning, Associated Transmission System and Comprehensive O&M for 5 (Five) Years of 20 MW (AC)/28 MWp (DC) Solar PV Power Plant and connecting Transmission lines at Dugdha Washery, BCCL- Dhanbad



1 INTRODUCTION

This document lays down the procedures and requirements for conducting Functional Guarantee tests including scope of the tests, procedures for the tests, reporting formats and process for determining test results in accordance with the Tender Specifications, applicable standards and industry best practices.

2 FUNCTIONAL GUARANTEE TESTS FOR SOLAR PV PLANT

Functional Guarantee for Solar PV Plant shall comprise of following Guarantees:

- (1) Performance Ratio Guarantee test for operational acceptance.

2.1 PERFORMANCE RATIO GUARANTEE TEST

A Performance Ratio Guarantee test shall be commenced within 60 days of the commissioning of Plant Facilities to demonstrate that the plant has achieved the Guaranteed Performance Ratio in line with requirements under section VII of the bidding document. This will be one of the pre-conditions for the Plant Operational Acceptance. Performance Ratio (PR) test period would be continuous measurement of 30 consecutive days. The test shall be conducted in accordance with the IEC-61724 as per the methodology described in Technical Specifications under section VII of the bidding document. The procedure of PR test is described further in Section 2.4. The report shall contain all the measured energy and Met data values, calculations, results and conclusions.

2.1.1 Performance Ratio

The Performance Ratio (PR) of the PV Plant is calculated as follows (according to IEC 61724 Ed.1).

$$PR = \frac{\left(\frac{E_{out}}{P_o}\right)}{\left(\frac{H_i}{G_{i,ref}}\right)}$$



Bharat Coking Coal Limited

Tender for Design, Engineering, Procurement & Supply, Construction & Erection, Testing, Commissioning, Associated Transmission System and Comprehensive O&M for 5 (Five) Years of 20 MW (AC)/28 MWp (DC) Solar PV Power Plant and connecting Transmission lines at Dugdha Washery, BCCL- Dhanbad



CNUL

where

- PR Performance Ratio
- E_{out} Cumulative AC energy measured at the Plant End ABT meter over the duration of reporting period (kWh)
- P_o Installed nominal peak power of PV modules, i.e. Nameplate rating at STC (kWp)
- H_i In-plane irradiation (kWh/m²)
- G_{i,ref} Irradiance value at which P_o is determined, i.e. 1 kW/m²

2.1.2 General Requirement

- The Functional Guarantee shall comprise of a set of visual/mechanical/Electrical checks followed by a Performance Ratio (PR) test of the Plant Facilities.
- The PR test shall be carried out for a period of 30 consecutive days at site by the Contractor in presence of the Employer/ Employer’s Representative/ Owner’s Engineer.
- These tests shall be binding on both the parties to the contract to determine compliance of the equipment with the guaranteed performance parameters.
- The test will consist of guaranteeing the correct operation of the Plant Facilities, byway of the performance ratio based on the reading of the energy produced and delivered to the grid (ABT meter) and the Plane of Array incident solar radiation.
- PR is calculated as per the formula given in Clause no. 2.1 and recorded as per the format provided at *Annexure 1*.
- The filled-in format shall be signed by both the parties (EPC Contractor and BCCL) and each party will keep one copy for record. **The same will be recorded for 30 consecutive days.**
- The Functional Guarantee condition for the purpose of Provisional Acceptance of the Plant Facilities shall be considered to have been met if the guaranteed Performance Ratio (PR) is achieved on a daily basis for 30 *consecutive days** as per Clause 2.1.5 of this document.



Bharat Coking Coal Limited

Tender for Design, Engineering, Procurement & Supply, Construction & Erection, Testing, Commissioning, Associated Transmission System and Comprehensive O&M for 5 (Five) Years of 20 MW (AC)/28 MWp (DC) Solar PV Power Plant and connecting Transmission lines at Dugdha Washery, BCCL- Dhanbad



- During this PR test, equipment failure/interruption of any kind, except for SCADA communication failures, will not be accountable. In case of a breakdown, the test may be resumed once the complete system is rectified and working properly.

2.1.3 Interruptions due to communication breakdown only may be exempted based on specific approval to the effect that generation is not affected and equipment failure (Refer Clause 2.1.5) is not attributable. In such case, the test shall be extended for affected no. of days (up to 5 days).

2.2 PRE-PR TEST

2.2.1 The EPC Contractor shall perform start-up tests after completion of Commissioning and Test Procedure as per Annexure-E: Plant Documentation, Commissioning and Test Procedure and recording of punch points.

2.2.2 Functional Guarantee Test shall commence immediately after all issues arising from the functional/ start-up test have been rectified.

Note:

- (a) All measurement(s) procedure should be carried out taking proper safety precaution.
- (b) Also, it should be ensured that to avoid any loose connection at the terminal points for which measurement procedure is conducted.
- (c) Ensure proper functioning (e.g. Multimeters shall be calibrated) of all measuring instruments before conducting above measurement procedure.
- (d) The above test procedure shall be conducted in presence of site in-charge.

2.3 PR TEST PROCEDURE

The date of commencement of the PR Test shall be communicated in advance and agreed upon by both parties i.e. BCCL and EPC Contractor. Any consecutive 30 days period (excluding interruptions that last entire day on account of grid outage or as per hindrance record maintained at site only) for the purpose of conducting PR test shall be mutually discussed and agreed between BCCL and EPC Contractor. It shall comprise of the following procedures.

2.3.1 Pre-test Procedure

- (1) Before the commencement of Performance Ratio (PR) test, the plant shall have achieved visual/mechanical/Electrical completion as per Clause 2.2 above and SCADA system and

20 MW (AC) Solar PV Power Plant at Dugdha, BCCL- Dhanbad, Jharkhand	<u>Tender No.</u>	172 Page
--	-----------------------------------	-------------------



Bharat Coking Coal Limited

Tender for Design, Engineering, Procurement & Supply, Construction & Erection, Testing, Commissioning, Associated Transmission System and Comprehensive O&M for 5 (Five) Years of 20 MW (AC)/28 MWp (DC) Solar PV Power Plant and connecting Transmission lines at Dugdha Washery, BCCL- Dhanbad



WMS shall be fully commissioned and functional.

- (2) Trial Run: The PG Test for Plant Facilities shall commence with a trial run for 7 consecutive days. The EPC Contractor shall provide the data in requisite formats (specified elsewhere in the document) to BCCL. BCCL shall vet the data for any discrepancies and systemic errors and revert within 3 working days. Post the trial run period, the 30 days PR test will commence after communication from BCCL in this regard.
- (3) Pyranometer Tilt Angle & Cleanness: The pyranometers & Tilt Angle shall be verified before the test commences and **then visually inspected at regular intervals for cleanliness during the tests.**
- (4) The average POA radiation of all the Pyranometers ($G_{i,j}$) shall be considered for the calculation of PR. The average of module temperatures recorded by all the temperature sensors shall be used for calculation of PR. The Pyranometers and Temperature sensors used for the purpose of the PR Test shall have valid calibration certificates.

2.3.2 Following the completion of the pre-test procedures, Performance Ratio Test of plant shall commence in accordance with the procedures, conditions and requirements provided in the next section.

2.3.3 General Procedure for the PR Test

The PR Test Procedure shall include the following components:

- (1) Data Collection: PV Power Plant test related parameters are collected in one-minute and 15 intervals for the 30 (Thirty) days (consecutive) reference period. The data shall consist of the following at a minimum:
 - Irradiance at Collector’s (i.e. PV Module) POA; (Source: SCADA, Temporal Resolution: 1 minute)
 - Other Met Data received from installed WMS; (Source: SCADA, Temporal Resolution: 1 minute)
 - Energy generated at Plant (kWh) (Source: Plant TVM Meter from SCADA, Temporal Resolution: 1 minute)
 - Energy injected into grid (kWh) (Source: Plant End ABT Meter, Temporal



Bharat Coking Coal Limited

Tender for Design, Engineering, Procurement & Supply, Construction & Erection, Testing, Commissioning, Associated Transmission System and Comprehensive O&M for 5 (Five) Years of 20 MW (AC)/28 MWp (DC) Solar PV Power Plant and connecting Transmission lines at Dugdha Washery, BCCL- Dhanbad



CNUL

Resolution: 15 minute

- PV Module Temperature recorded from the temperature Sensors (°C) (Source: SCADA, Temporal Resolution: 1 minute)

(2) Data Filtering: The data shall be filtered so that the data set is free of nuisance datapoints and bad data that exhibit a high degree of error (such as errors caused by faulty instrumentation). The EPC Contractor shall document data which is to be eliminated along with reasons. The following criteria shall be excluded from the dataset used for this test:

- **Nuisance or bad data** – Nuisance data points or bad data that clearly exhibit a high degree of error including required meteorological measurement equipment that is identified as being out of calibration or requiring adjustment. A 15-minute time-block shall be *explicitly* flagged through a flag parameter on account of this factor after recording reasons thereof (**Note:** no filtration shall be done at site level). The same shall be corroborated/verified by BCCL.
- Time blocks with insufficient (less than equal to 10) 1-minute records.
- **Grid Interruptions** – Time periods (in 15-minute time blocks) of the grid interruptions at the utility substation, recorded manually jointly by EPC Contractor and BCCL representatives shall be eliminated. Grid outage period, if any, shall be verified from SCADA.
- Any Force majeure conditions
- **Radiation Criteria** – Radiation on Plane of Array (POA) less than 200 W/m²
- Shutdown explicitly demanded by the Owner/DISCOM/STU.
- As per the hindrance record maintained at site.

Note: Minimum 24 Nos of 15-minute time blocks shall be considered to account the day for PR measurement. Otherwise the PR test shall be extended to another day.

2.3.4 Determination of PR Test

Daily PR shall be calculated as the average of the PR calculated for valid 15-minute time blocks

20 MW (AC) Solar PV Power Plant at Dugdha, BCCL- Dhanbad, Jharkhand	<u>Tender No.</u>	174 Page
--	-----------------------------------	-------------------



Bharat Coking Coal Limited

Tender for Design, Engineering, Procurement & Supply, Construction & Erection, Testing, Commissioning, Associated Transmission System and Comprehensive O&M for 5 (Five) Years of 20 MW (AC)/28 MWp (DC) Solar PV Power Plant and connecting Transmission lines at Dugdha Washery, BCCL- Dhanbad



CNUL

for the 30-day duration. If the ABT Meter data is not available on daily basis, PR shall be calculated based on the MFM data and shared for record. However, at the end of the PR test period, the daily PR shall be re-calculated with the ABT Meter data for sign-off.

If the EPC Contractor is not able to demonstrate guaranteed PR during this period, two more chances shall be given to demonstrate the same after incorporation of suitable corrective measures. In case the contractor fails to achieve guaranteed PR even after the two more chances, further action shall be taken as per the provisions of contract.

The test shall be repeated for 30 days in case of any outage of following equipment (as applicable) for more than 7 days.

- Power Transformer/Inverter Duty Transformer
- Power Conditioning Unit
- HT Switchgear Panel
- SCADA and data logger combined
- Tilted pyranometer
- Other WMS sensors.

2.3.5 Raw Data Formats and Reports

The EPC Contractor shall submit to BCCL the raw data from the Plant SCADA on daily basis in the following format.

The EPC Contractor shall submit to BCCL the raw data from the Plant SCADA on daily basis in the following format.



Bharat Coking Coal Limited

Tender for Design, Engineering, Procurement & Supply, Construction & Erection, Testing, Commissioning, Associated Transmission System and Comprehensive O&M for 5 (Five) Years of 20 MW (AC)/28 MWp (DC) Solar PV Power Plant and connecting Transmission lines at Dugdha Washery, BCCL- Dhanbad



Temporal Resolution: 1 Minute

Date & Time dd/mm/yyyy hh:mm:ss format	Wind Speed (m/s)	Module Temp. (°C)	Ambient Temp. (°C)	Horizontal Irradiance (W/m ²)	POA Irradiance (W/m ²)	POA Radiation (kWh/m ²)	Humidity (%)	Wind Direction (°)	Generation (kWh) (Source: TVM)
---	---------------------	----------------------	-----------------------	--	---------------------------------------	--	--------------	--------------------	-----------------------------------

Temporal Resolution: 15 Minute (Every 15th Min record from the 1 Min Data)

Date & Time dd/mm/yyyy hh:mm:ss format	Wind Speed (m/s)	Module Temp. (°C)	Ambient Temp. (°C)	Horizontal Irradiance (W/m ²)	POA Irradiance (W/m ²)	POA Radiation (kWh/m ²)	Humidity (%)	Wind Direction (°)	Generation (kWh) (Source: TVM)	Explicit Removal Flag* (0 or 1)	Remarks
---	---------------------	----------------------	-----------------------	--	---------------------------------------	--	--------------	--------------------	-----------------------------------	------------------------------------	---------

* Explicit Removal Flag: 0 indicates time block considered; 1 indicates time block not considered.

PR Test Report shall be generated from the Raw Data (Sample Report provided in the Annexure) after data filtering as per criteria laid out in (2). The Report shall contain the signature of both representatives (BCCL/Employer & EPC Contractor).

Note: In case of multiple pyranometers/temperature sensors, the radiation and temperature data for the purpose of calculation of PR shall be derived from the average values from tilted pyranometer /temperature sensors.

2.4 CAPACITY UTILIZATION FACTOR (CUF)

Capacity Utilization Factor for Solar Plant shall be calculated as per the following formula.

$$CUF = \frac{E_{ac} + E_{outage}}{8760 \times P_{ac} \times (1 - DF \times (N - 1)) \times RCF}$$

E_{ac} Number of units recorded in ABT meter at interconnecting substation excluding auxiliary consumption, kWh

E_{outage} Energy adjusted for grid outage hours



Bharat Coking Coal Limited

Tender for Design, Engineering, Procurement & Supply, Construction & Erection, Testing, Commissioning, Associated Transmission System and Comprehensive O&M for 5 (Five) Years of 20 MW (AC)/28 MWp (DC) Solar PV Power Plant and connecting Transmission lines at Dugdha Washery, BCCL- Dhanbad



$$E_{\text{outage}} = \sum_{i=1}^{12} E_{i,\text{avg}} \times Q_i$$

$E_{i,\text{avg}}$ Average energy generated per hour during i^{th} month

$E_{i,\text{avg}} = (\text{Cumulative number of units recorded in ABT meters of all the interconnecting substations during } i^{\text{th}} \text{ month}) / (\text{Number of days in } i^{\text{th}} \text{ month} \times 24)$

Q_i Number of grid outage hours during i^{th} month

(The Contractor shall submit grid outage certification from competent authority of STU/DISCOM).

$i = 1$ corresponds to the calendar month on which Operational Acceptance is achieved.

8760 Number of hours in non-leap year. It shall be replaced by 8784 hours during leap year

P_{ac} Plant AC capacity, 25,000 kW

DF Module degradation factor, 0.7% per year

N Number of years of operation after operational acceptance of the plant

RCF Radiation Correction Factor

$$RCF = \frac{\text{Measured Irradiation}}{\text{Reference Irradiation}}$$

where Reference Irradiation = 1808 kWh/m² and Measured Irradiation (GHI_{mes}) shall be recorded from the Pyranometer installed in horizontal plane at the site location. The radiation data of the Pyranometer shall be compared with the Reference Irradiation mentioned above. The radiation data from the Plant Pyranometer shall be used for computation of CUF, except in case of any discrepancy (i.e. more than ± 10% variation from the Reference Radiation, GHI_{ref}), in which case the radiation data from the nearest available Solar Radiation Resource Assessment (SRRA) station data will be used for computation of CUF. Missing data (GHI_{mes}) from the Plant Pyranometer shall be substituted by average of GHI measured for the same period in the past



Bharat Coking Coal Limited

Tender for Design, Engineering, Procurement & Supply, Construction & Erection, Testing, Commissioning, Associated Transmission System and Comprehensive O&M for 5 (Five) Years of 20 MW (AC)/28 MWp (DC) Solar PV Power Plant and connecting Transmission lines at Dugdha Washery, BCCL- Dhanbad



CNUL

three (3) days. The plant Pyranometer has to be under CCTV coverage.

CUF shall be calculated on annual basis from the date of operational acceptance of the plant till the end of O&M period. Module degradation factor will not be considered for first year CUF calculation. It is the Contactor's responsibility to envisage and install extra DC capacity to accommodate any degradation during first year. Module degradation factor, as per above will be considered from second year of operation.

**20 MW (AC) Solar PV Power
Plant at Dugdha, BCCL-
Dhanbad, Jharkhand**

Tender No.

.....

178 | Page



Bharat Coking Coal Limited

Tender for Design, Engineering, Procurement & Supply, Construction & Erection, Testing, Commissioning, Associated Transmission System and Comprehensive O&M for 5 (Five) Years of 20 MW (AC)/28 MWp (DC) Solar PV Power Plant and connecting Transmission lines at Dugdha Washery, BCCL- Dhanbad



Reports

Sample Report for PR Test

PR Guarantee Test Report

Day: **20-Nov-2016** Criteria: **>200** Average POA Irradiance in a timeblock in W/m²

No. of Timeblocks considered: **36 / 42** Tot Gen: **53694 kWh** Source: ABT Meter at GSS

Plant PR for the day ABT: **80.66%** Average PR (temp corrected) of 15 min time blocks where POA Irradiance is greater than 302W/m² and not explicitly removed (Guaranteed PR: 78%)

Time Block (hh:mm)	Wind Speed (m/s)	Module Temp. (°C)	Ambient Temp. (°C)	POA Radiation (kWh/m ²)	Plane of Array Irradiance (W/m ²)	GHI (W/m ²)	Humidity (%)	Wind Direction (°)	Generation ABT GSS (kWh)	AC Power ABT kW (Co in 1.0.1)	PR ABT	Temp Corrected PR ABT	Explicit Removal
7:2	1.62	13.91	15.10	2.17	25.25	27.00	45.92	88.10	0.00	0.00	0.00%	0.00%	0
7:3	1.41	14.47	15.25	12.34	47.92	50.47	45.53	38.35	21.00	8.40	14.73%	14.10%	0
7:4	0.57	15.84	15.73	25.08	98.48	92.93	44.41	0.00	79.00	31.60	27.27%	26.24%	0
8:1	0.26	17.73	16.01	39.51	156.11	143.67	44.55	0.00	212.00	84.80	46.45%	45.07%	0
8:2	0.66	20.64	17.01	54.73	216.78	193.67	42.19	0.00	361.00	144.40	57.10%	56.08%	0
8:3	0.43	24.09	17.94	70.40	279.62	245.80	40.17	0.00	526.00	210.40	64.69%	64.45%	0
8:4	0.71	27.22	18.85	86.46	343.62	291.80	38.39	0.00	688.00	275.20	68.90%	69.52%	0
9:1	0.71	29.93	19.74	102.34	407.36	348.47	36.74	0.00	854.00	341.60	72.25%	73.71%	0
9:2	0.71	32.98	20.73	117.25	466.99	398.00	35.17	0.00	1009.00	403.60	74.51%	76.95%	0
9:3	0.80	35.60	21.52	132.28	527.14	445.27	33.94	0.00	1151.00	460.40	75.33%	78.61%	0
9:4	0.74	38.17	22.31	146.86	585.56	486.27	32.98	0.00	1283.00	513.20	75.64%	78.72%	0
10:1	0.87	40.55	23.23	160.77	641.34	516.87	31.86	0.00	1406.00	562.40	75.72%	80.54%	0
10:2	0.93	42.99	24.08	173.62	692.91	540.33	31.13	0.00	1518.00	607.20	75.70%	81.28%	0
10:3	0.99	43.76	24.76	184.38	736.02	559.67	30.67	0.00	1613.00	645.20	75.74%	81.57%	0
10:4	1.18	44.44	25.53	194.12	775.43	576.53	29.87	12.76	1695.00	678.00	75.60%	81.63%	0
11:1	1.05	46.52	26.17	203.12	811.43	593.60	28.97	0.00	1765.00	706.00	75.23%	81.87%	0
11:2	0.89	48.11	26.74	210.57	841.02	609.07	28.28	0.00	1824.00	729.60	75.00%	82.10%	0
11:3	1.51	47.95	27.61	217.05	867.66	624.60	26.97	0.00	1877.00	750.80	74.87%	81.92%	0
11:4	2.03	48.74	28.04	222.77	890.54	642.47	25.69	76.95	1932.00	772.80	75.09%	82.40%	0
12:1	1.61	49.61	28.91	225.54	902.04	656.13	24.24	0.00	1975.00	790.00	75.82%	83.47%	0
12:2	2.03	49.58	29.45	225.55	902.30	664.40	22.97	129.40	1998.00	799.20	76.69%	84.42%	0
12:3	2.34	49.79	29.73	227.09	907.75	672.60	21.62	131.02	2018.00	807.20	76.94%	84.75%	0
12:4	2.48	49.66	29.92	223.65	895.29	671.87	20.71	96.20	2034.00	813.60	76.74%	86.70%	0
13:1	2.10	49.70	30.20	224.96	899.51	670.93	18.75	0.00	2019.00	807.60	77.71%	85.71%	0
13:2	2.32	49.80	30.31	222.11	889.25	665.80	18.11	22.42	2024.00	809.60	78.90%	86.92%	0
13:3	2.59	49.39	30.42	219.07	877.23	649.13	17.75	219.19	2005.00	802.00	79.24%	87.17%	0
13:4	2.22	49.55	30.70	215.00	859.72	630.67	17.39	0.00	1980.00	792.00	79.73%	87.76%	0
14:1	1.87	49.88	30.98	213.62	855.38	620.80	16.27	0.00	1944.00	777.60	78.79%	86.83%	0
14:2	2.27	47.80	31.28	203.86	816.52	584.27	16.13	19.15	1906.00	762.40	80.95%	88.51%	0
14:3	2.30	47.34	30.99	196.95	789.89	548.20	16.46	38.30	1825.00	730.00	80.23%	87.58%	0
14:4	2.05	47.88	31.01	189.95	760.16	520.20	16.53	7.33	1754.00	701.60	79.95%	87.45%	0
15:1	1.75	45.99	31.44	180.73	724.65	484.80	15.75	0.00	1674.00	669.60	80.19%	87.10%	0
15:2	2.30	44.51	31.33	170.69	684.26	442.27	15.51	95.39	1576.00	630.40	79.94%	86.34%	0
15:3	2.10	44.35	31.19	160.33	642.47	402.40	15.57	28.93	1462.00	584.80	78.95%	85.21%	0
15:4	2.33	41.86	31.19	148.67	596.65	358.47	15.41	45.73	1350.00	540.00	78.62%	84.06%	0
16:1	1.91	41.25	31.19	135.70	544.70	311.80	15.33	90.91	1220.00	488.00	77.94%	83.02%	0
16:2	2.37	38.99	31.12	118.23	475.45	255.73	14.96	5.47	1080.00	432.00	79.09%	83.62%	0
16:3	2.57	36.66	30.95	96.68	389.67	195.27	15.01	86.82	829.00	331.60	74.24%	77.79%	0
16:4	1.60	34.83	30.62	70.86	306.83	143.86	15.44	76.91	531.00	212.40	64.88%	67.50%	0
17:1	1.56	32.61	30.19	52.45	212.88	92.47	15.59	63.97	350.00	140.00	57.26%	53.50%	0
17:2	1.75	29.57	29.88	26.61	117.56	48.14	15.94	103.66	226.00	90.40	73.53%	74.91%	0
17:3	0.84	27.22	28.80	4.19	52.66	21.40	16.82	0.00	100.00	40.00	206.71%	208.59%	0

Note: Explicit Removal (0 - considered, 1 - Not considered)

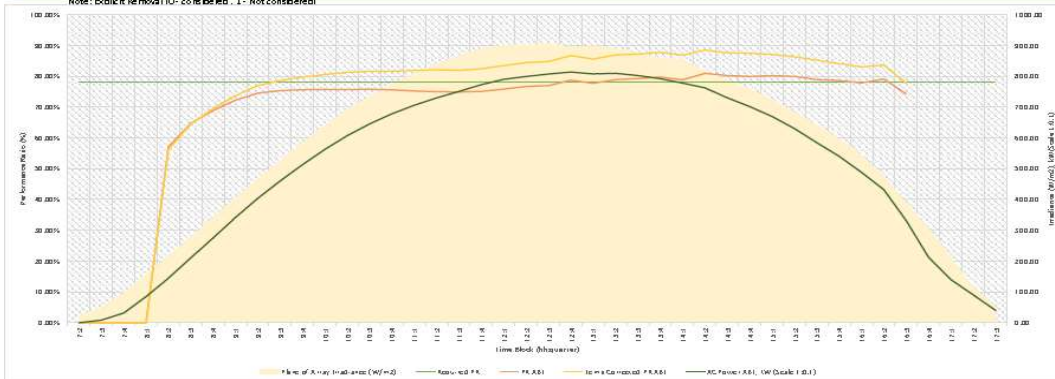

Remarks: [to be recorded, if any]

20 MW (AC) Solar PV Power Plant at Dugdha, BCCL- Dhanbad, Jharkhand

Tender No.



Bharat Coking Coal Limited

Tender for Design, Engineering, Procurement & Supply, Construction & Erection, Testing, Commissioning, Associated Transmission System and Comprehensive O&M for 5 (Five) Years of 20 MW (AC)/28 MWp (DC) Solar PV Power Plant and connecting Transmission lines at Dugdha Washery, BCCL- Dhanbad



CNUL

2.5 LIQUIDATED DAMAGES FOR SHORTFALL IN PR

For every 0.01 shortfall in PR below the committed PR value, a penalty of 1% of the total Contract Value (i.e., total sum of all the Supply, Service and absolute value of O & M Contract) shall be levied. In case the Contract Performance Security has already been encashed on account of any default/delays, the penalty amount will be recovered from any due payments to the contractor. In case the Plant PR Shortfall is more than 0.05 than the specified PR value, then the total plant will be accepted on as-is basis & the total Contract Performance Security submitted by the contractor will be forfeited & payments linked to operational acceptance will not be made.

2.6 LIQUIDATED DAMAGES FOR SHORTFALL IN DECLEARED NEEGG

Please Refer **SPECIAL CONDITIONS OF CONTRACT (SECTION-6)**

2.7 INCENTIVES FOR EXCESS GENERATION

Any excess generation over and above the Expected energy on annual basis, as per the table below, subject to upper limit of 110% of the same, shall be entitled to an incentive of 50% of PPA tariff per unit of energy injected:

Minimum expected Energy Injected (MUs) in Nth Year for Incentives*:

$$P_{ac} * 8760 * CUF_e * (1 - DF \times (N - 1))$$

P_{ac} Plant AC capacity, 25,000 kW

DF Module degradation factor, 0.7% per year

N Number of years of operation after operational acceptance of the plant

CUF_e 23.2%

* subject to upper limit of 110% of the energy calculated as per below formula



Bharat Coking Coal Limited

Tender for Design, Engineering, Procurement & Supply, Construction & Erection, Testing, Commissioning, Associated Transmission System and Comprehensive O&M for 5 (Five) Years of 20 MW (AC)/28 MWp (DC) Solar PV Power Plant and connecting Transmission lines at Dugdha Washery, BCCL- Dhanbad



CNUL

**ANNEXURE – D
MANDATORY SPARES**

S. No.	Equipment/Material	Quantity (for each type and rating)
1	PV Modules	0.5% of total supply
2	String Monitoring Unit	1% of total supply
3	MC4 connectors (including Y-connector if used)	1% of total supply
4	Power Conditioning Unit	
	(i) Central Inverter	As per OEM recommendation
	(ii) String Inverter	1% of total supply
5	Inverter Transformer	
	(i) HV bushing with metal parts and gaskets	2 set
	(ii) LV bushing with metal parts and gaskets	2 set
	(iii) Complete set of gaskets	2 set
6	HT Switchgear	
	(i) Vacuum pole	2 nos.
	(ii) Closing coil	2 nos.
	(iii) Tripping coil	2 nos.
	(iv) Spring charging motor	2 nos.
	(v) Relay	2 nos.
	(vi) Meter	2 nos.
	(vii) Current Transformer	2 nos.
	(viii) Voltage Transformer	2 nos.
	(ix) MCCB	2 nos.
	(x) MCB	2 nos.
	(xi) Fuse	10% of total supply
	(xii) Indicating lamp	10% of total supply

**20 MW (AC) Solar PV Power
Plant at Dugdha, BCCL-
Dhanbad, Jharkhand**

Tender No.

.....

181 | Page



Bharat Coking Coal Limited

Tender for Design, Engineering, Procurement & Supply, Construction & Erection, Testing, Commissioning, Associated Transmission System and Comprehensive O&M for 5 (Five) Years of 20 MW (AC)/28 MWp (DC) Solar PV Power Plant and connecting Transmission lines at Dugdha Washery, BCCL- Dhanbad



CNUL

	(xiii) Push button	10% of total supply
	(xiv) Rotary switch	10% of total supply
7	LT Switchgear	
	(i) MCCB	2 nos.
	(ii) MCB	2 nos.
	(iii) Fuse	10% of total supply
	(iv) Relay	2 nos.
	(v) Meter	2 nos.
	(vi) Current Transformer	2 nos.
	(vii) Voltage Transformer	2 nos.
	(viii) Indicating lamp	10% of total supply
	(ix) Push button	
	(x) Rotary switch	10% of total supply
8	Solar Cable	5% of total supply
9	DC Cable	5% of total supply
10	AC Cable	5% of total supply
11	Communication Cable	5% of total supply

Notes:

- Wherever percentage is specified, number of spares shall be rounded off to next higher integer.
- Spares, if used, during the O&M period shall be replenished by the Contractor. All the mandatory spares shall be handed over to the Employer in working condition at the end of O&M period.



Bharat Coking Coal Limited

Tender for Design, Engineering, Procurement & Supply, Construction & Erection, Testing, Commissioning, Associated Transmission System and Comprehensive O&M for 5 (Five) Years of 20 MW (AC)/28 MWp (DC) Solar PV Power Plant and connecting Transmission lines at Dugdha Washery, BCCL- Dhanbad



Annexure – E

Procedure for Plant Testing, Commissioning and Test Procedure

20 MW (AC) Solar PV Power Plant at Dugdha, BCCL- Dhanbad, Jharkhand

Tender No.

.....

183 | Page



Bharat Coking Coal Limited

Tender for Design, Engineering, Procurement & Supply, Construction & Erection, Testing, Commissioning, Associated Transmission System and Comprehensive O&M for 5 (Five) Years of 20 MW (AC)/28 MWp (DC) Solar PV Power Plant and connecting Transmission lines at Dugdha Washery, BCCL- Dhanbad



CNUL

TABLE OF CONTENTS

1 INTRODUCTION184

2 CODES AND STANDARDS.....184

3 COMMISSIONING.....184

3.1 General 184

4 Cold Commissioning at PAC.....185

4.1 DC Commissioning185

4.2 AC Commissioning190

4.3 IV Curve Testing.....194

5 Hot Commissioning at PAC.....195

5.1 Infrared Inspection195

5.2 Inverter Availability Test196

5.3 Single Axis Tracker Availability Test.....197

5.4 SCADA and Weather Station Reliability197



Bharat Coking Coal Limited

Tender for Design, Engineering, Procurement & Supply, Construction & Erection, Testing, Commissioning, Associated Transmission System and Comprehensive O&M for 5 (Five) Years of 20 MW (AC)/28 MWp (DC) Solar PV Power Plant and connecting Transmission lines at Dugdha Washery, BCCL- Dhanbad



1 INTRODUCTION

This document lays down the procedures, requirements and templates for conducting commissioning tests and inspection of the Plant Facilities after installation and for subsequent re-inspection, maintenance or modifications in accordance with the Tender Specifications, IEC 62446 standard (Part 1: Grid connected systems – Documentation, commissioning tests and inspection)- and industry best practices.

2 CODES AND STANDARDS

The Testing and Commissioning Procedures shall, in general, comply with the following standards:

1. IEC 62446 standard (Part 1: Grid connected systems – Documentation, commissioning tests and inspection).
2. IEC 60364-6:2016 - Low voltage electrical installations - Part 6: Verification.
3. IEC 61829:2015: Photovoltaic (PV) array - On-site measurement of current-voltage characteristics.
4. IEC 60904-4:2019 Photovoltaic devices - Part 4: Reference solar devices - Procedures for establishing calibration traceability
5. IEC TS 60904-1-2:2019 - Photovoltaic devices - Part 1-2: Measurement of current- voltage characteristics of bifacial photovoltaic (PV) devices
6. IEC 62305-3– Protection against lightning - Part 3: Physical damage to structures and life hazard
7. IS/IEC 61557: Part 2: 2007 - Electrical safety in low voltage distribution systems up to 1000 V ac and 1500 V dc - Equipment for testing, measuring or monitoring of protective measures: Part 2 insulation resistance

3 COMMISSIONING

3.1 GENERAL

3.1.1 Objective

The Commissioning Procedure defined in this document aims to:

- Verify that the power plant is structurally and electrically safe
- Verify that the power plant is structurally and electrically robust to operate for the specified lifetime of a project
- Verify that the power plant operates as designed and its performance is as expected



Bharat Coking Coal Limited

Tender for Design, Engineering, Procurement & Supply, Construction & Erection, Testing, Commissioning, Associated Transmission System and Comprehensive O&M for 5 (Five) Years of 20 MW (AC)/28 MWp (DC) Solar PV Power Plant and connecting Transmission lines at Dugdha Washery, BCCL- Dhanbad



3.1.2 General Requirements before Starting the Commissioning Process

- The modules shall be stabilized (sufficiently exposed after 200 kWh/m² reaching the PV plane)
- The tests shall be conducted under stable weather conditions
- The process shall be witnessed by the Owner or their duly appointed representative.
- Soiling losses shall not be accounted for in the assessment of Results. Therefore, adequate Module cleaning exercise shall be undertaken prior to commencement of Commissioning process.
- The following equipment shall be used during the commissioning process (Refer Section VII B: Technical Specifications for testing instruments):
 - Earth resistance tester
 - IV curve tracer
 - Insulation tester
 - Digital multimeter
 - Clamp meter
 - Infrared camera
 - Digital lux meter
 - Electroluminescence camera, power supply and accessories
- All testing equipment shall possess valid calibration certificate issued from approved laboratories.

4 Cold Commissioning

4.1 DC COMMISSIONING

4.1.1 Visual Inspection

The visual inspection shall be conducted on 5% of the system split in subareas equally distributed in the field. Unless otherwise specified, Approved Cat I Drawings shall be referred for correctness/verification. At least following aspects shall be verified visually on the DC side:

- Sizing of the DC fuses for running conditions, for the maximum voltage and the maximum current.
- Sizing of the string cables including overcurrent protection considering the current carrying capacity under operating conditions



Bharat Coking Coal Limited

Tender for Design, Engineering, Procurement & Supply, Construction & Erection, Testing, Commissioning, Associated Transmission System and Comprehensive O&M for 5 (Five) Years of 20 MW (AC)/28 MWp (DC) Solar PV Power Plant and connecting Transmission lines at Dugdha Washery, BCCL- Dhanbad



CNUL

- Cables protected against mechanical damage
- Functionality of the main DC switch
- Fixation of the modules to the mounting structure
- Termination of the cables to the inverter
- Where the PV system includes functional earthing of one of the DC conductors, the functional earth connection shall be specified and installed to the requirements of IEC 62548.
- Laying and installation of cables
- Fixation of the grounding electrodes
- Grounding of all conductive parts and connected to the equipotential bonding system of the PV plant
- The torque values in the mounting structure, combiner boxes, bars and joints shall match the manufacturer specifications
- Where protective earthing and/or equipotential bonding conductors are installed, they shall be parallel to and bundled with the DC cables
- Electrical circuits and devices shall be labelled.
- The PV modules shall be in a good condition (no visible serial defects such as yellowing, delamination, scratches, etc.).
- Functioning of fire protection equipment.

Acceptance criteria

Each deviation from industrial best practices, norms, standards and good workmanship shall be documented in a punch list. All items shall be categorized as “critical”, “important” or “minor”.

4.1.2 Pre-Energizing Tests

4.1.2.1 Measuring instruments and monitoring equipment and methods shall be chosen in accordance with the relevant parts of IEC 61557 and IEC 61010. The following tests shall be carried out on the DC circuit forming the PV array in accordance with a Sampling Plan:

- Electrical Continuity test: This test shall be performed on the earthing and/or equipotential bonding conductors, in the PV array field. Connection of such conductors to earthing pit shall also be verified .



Bharat Coking Coal Limited

Tender for Design, Engineering, Procurement & Supply, Construction & Erection, Testing, Commissioning, Associated Transmission System and Comprehensive O&M for 5 (Five) Years of 20 MW (AC)/28 MWp (DC) Solar PV Power Plant and connecting Transmission lines at Dugdha Washery, BCCL- Dhanbad



- Polarity test: Polarity of DC cables shall be verified. After verifying the correctness of polarity, marking on cable shall be checked for correctness

Note: Polarity test shall be performed before closing the switches or string overcurrent protective devices are inserted

- Combiner box test: The purpose of this test is to ensure all strings are connected correctly to the combiner box. The test procedure is as follows and shall be performed before any string fuses / connectors are inserted for the first time:

- i) Select a volt meter with voltage range at least twice the maximum system voltage.
 - ii) Insert all negative fuses / connectors so strings share a common negative bus.
 - iii) Do not insert any positive fuses / connectors.
 - iv) Measure the open circuit voltage of the first string, positive to negative, and ensure it is an expected value.
 - v) Leave one lead on the positive pole of the first string tested, and put the other lead on the positive pole of the next string. Because the two strings share a common negative reference, the voltage measured should be near-zero, with an acceptable tolerance range of ± 15 V.
 - vi) Continue measurements on subsequent strings, using the first positive circuit as the meter common connection.
 - vii) A reverse polarity condition will be very evident if it exists – the measured voltage will be twice the system voltage.
- String open circuit voltage test, V_{oc} (under stable weather conditions): The purpose of this test is check the modules connection in string as per the design. The V_{oc} of PV string should be measured using suitable measuring device before closing any switch or string overcurrent protective devices, where fitted.

The measured string V_{oc} will be assessed to ensure it matches the expected value (typically within 5 %) in one of the following ways:

- a) Compare with the expected value derived from the module datasheet or from a detailed PV model that takes into account the type and number of modules and the module cell temperature.
 - b) Measure V_{oc} on a single module, then use this value to calculate the expected value for the string.
 - c) For systems with multiple identical strings, voltages between strings can be compared.
- String circuit current test, I_{sc} (under stable weather conditions): The purpose of this test to check



Tender for Design, Engineering, Procurement & Supply, Construction & Erection, Testing, Commissioning, Associated Transmission System and Comprehensive O&M for 5 (Five) Years of 20 MW (AC)/28 MWp (DC) Solar PV Power Plant and connecting Transmission lines at Dugdha Washery, BCCL- Dhanbad



the correctness of system, operational characteristic and PV array wiring. These tests are not to be taken as a measure of module / array performance. The test procedure will be as follows:

- i) Ensure that all switching devices and disconnecting means are open and that all PV strings are isolated from each other.
- ii) Create a temporary short circuit into string under test by using any of the following method:
 - (a) use of a test instrument with a short circuit current measurement function (e.g. a specialized PV tester);
 - (b) a short circuit cable temporarily connected into a load break switching device already present in the string circuit;
 - (c) use of a “short circuit switch test box” – a load break rated device that can be temporarily introduced into the circuit to create a switched short circuit.
- iii) Measure the short circuit current (Isc) using a suitably rated measuring instrument.
- iv) After taking the reading, interrupt the short circuit using a suitable load break switching device and check the zero value of current before changing any other connections.
- v) Compare the measure value of Isc with the expected value. For systems with multiple identical strings, measurements of currents in individual strings shall be compared. These values should be the same (typically within 5 % of the average string current). Note: An I-V curve test can be performed as an alternative to this test (see 4.3).
- Functional tests: The following functional tests shall be performed:
 - i) Switchgear and other control apparatus shall be tested to ensure correct operation and that they are properly mounted and connected.
 - ii) All inverters forming part of the PV system shall be tested to ensure correct operation. The test procedure should be as defined by the inverter manufacturer.

Functional tests that require the AC supply to be present (e.g. inverter tests) shall only be performed once the AC side of the system has been tested.

- Insulation resistance of the DC circuits: Test procedure to conduct this test will be as follows:
 - i) Before commencing the test adopt the following safety measure to avoid any potential shock hazard
 - (a) Isolate the testing area.
 - (b) Do not touch any metallic surface, module backsheet or the module terminals when performing the insulation test.

<p>20 MW (AC) Solar PV Power Plant at Dugdha, BCCL- Dhanbad, Jharkhand</p>	<p align="center"><u>Tender No.</u> <u>.....</u></p>	<p align="right">189 Page</p>
---	---	--



Bharat Coking Coal Limited

Tender for Design, Engineering, Procurement & Supply, Construction & Erection, Testing, Commissioning, Associated Transmission System and Comprehensive O&M for 5 (Five) Years of 20 MW (AC)/28 MWp (DC) Solar PV Power Plant and connecting Transmission lines at Dugdha Washery, BCCL- Dhanbad



- (c) Appropriate personal protective clothing / equipment should be worn for the duration of the test.
- ii) Isolate the PV array from the inverter (typically at the array switch disconnecter)
- iii) Disconnect any piece of equipment that could have impact on the insulation measurement (i.e. overvoltage protection) in the junction or combiner boxes.
- iv) The insulation resistance test device shall be connected between earth and the array cable(s) or combiner bus bar. Connections can be made between earth and array negative followed by a test between earth and array positive or between earth and shortcircuited array positive and negative.
- v) Follow the IR test device instructions to ensure the test voltage and readings in megaohms. When the system voltage (Voc at STC X 1.25) is higher than 500V, the test voltage shall be 1,000V and the minimum insulation resistance 1 MΩ.
- vi) Ensure the system is de-energized before removing test cables or touching any conductive parts.

4.1.2.2 Sampling Plan:

At least 2 strings from 2 SMUs shall be randomly chosen by the Owner connected to each Inverter.

Acceptance criteria

The DC commissioning will be passed when the aforementioned verifications are successfully passed in 100% of the sample according to the IEC 62446: 2016 – 5 and IEC 62446:2016 – 6.

4.2 AC COMMISSIONING

4.2.1 Visual Inspection

The visual inspection shall be conducted on 5% of the system. In general, the requirements specified in the IEC 60364-6 -6.4.2 apply. At least following aspects shall be verified visually on the AC side:

4.2.1.1 General requirements

- Protective requirements against electric shock
- Protection against fire and heat
- Choice, setting, selectivity and coordination of protective and monitoring devices
- Sizing of cables regarding voltage drop and ampacity as per approved Drawings.
- Sizing of protective and monitoring devices as per approved Drawings
- The circuit breakers are correctly located
- Selection, location and installation of suitable isolating, overvoltage protective devices and switching
- The equipment and protective measures are appropriate for the external influences and



Bharat Coking Coal Limited

Tender for Design, Engineering, Procurement & Supply, Construction & Erection, Testing, Commissioning, Associated Transmission System and Comprehensive O&M for 5 (Five) Years of 20 MW (AC)/28 MWp (DC) Solar PV Power Plant and connecting Transmission lines at Dugdha Washery, BCCL- Dhanbad



CNUL

mechanical stresses

- The diagrams, warning notices or similar information attached to the wall inside the inverter housing or the control room
- Proper fixation of the cables to the collector bars in the AC combiner box
- Proper labelling of all electrical circuits and devices including the neutral conductor and protective conductor as well as correct connection of single pole devices to the phase conductors
- Adequacy of termination and connection of cables and conductors
- The warning labels and technical documentation physically displayed
- Selection and installation of earthing arrangements, protective conductors and their connections
- The existence and correct use of protective conductors and protective equipotential bonding conductors (PEB)
- Measures against electromagnetic disturbances implemented
- Easy access to the operational devices for maintenance
- Any exposed conductive parts connected to the earthing system
- The RCD type has been selected according to the requirements of the IEC 62548
- The isolation means of the inverter on the AC side are functional and correctly sized
- The fire protection requirements according to the approved design shall be given

4.2.1.2 Requirements for the inverter

- Installation as per manufacturer’s instructions and compliance with IEC 62548
- Inverters properly fastened to the ground
- Inverter properly earthed
- Inverter incoming/outgoing cables properly isolated, labelled and connected
- The connections for phase sequence L1, L2, L3 and N in the correct order
- All cable terminations properly done
- Nameplate data. The minimum requirements for the production of a name plate are –
 - name and origin of the manufacturer; –
 - model or type name;
 - serial number;
 - electrical parameters: V_{dcmax} , V_{mppmin} , V_{mppmax} , I_{dcmax} , $P_{ac,r}$, $V_{ac,r}$, f_r , I_{acmax} ;
 - degree of protection;
 - overvoltage category;



Bharat Coking Coal Limited

Tender for Design, Engineering, Procurement & Supply, Construction & Erection, Testing, Commissioning, Associated Transmission System and Comprehensive O&M for 5 (Five) Years of 20 MW (AC)/28 MWp (DC) Solar PV Power Plant and connecting Transmission lines at Dugdha Washery, BCCL- Dhanbad



- safety class.
- The displays - check / readout show plausible results
- The filters are clean and properly maintained
- The cooling outputs of the inverters are free from obstruction
- The DC circuit breaker is functional
- The DC insulation monitoring correctly installed
- The fuses at the DC entrance correctly sized
- The location of the inverter(s) in the field matches the approved design
- Protection against self-loosening of clamps and screws
- The string inverter anchored to the mounting structure
- The mechanical assembly is robust
- The inverters are fixed to non-flammable mechanical elements

Acceptance criteria

Each deviation from industrial best practices, norms, standards and good workmanship shall be documented in a punch list. The punch list shall represent a maximum budget of 1% of the construction price and all items shall be categorized as “critical”, “important” or “minor”.

4.2.2 Pre-Energizing Tests

Measuring instruments and monitoring equipment and methods shall be chosen in accordance with the relevant parts of IEC 61557 and IEC 61010. The following tests shall be carried out on the AC circuit forming the PV array:

- Continuity of conductors. The requirements in IEC 60364-6:2016 – 6.4.3.2 apply
- Insulation resistance of the electrical installation. The requirements in IEC 60364-6:2016 – 6.4.3.3 apply
- Insulation resistance testing to confirm the effectiveness of protection by SELV, PELV or electrical separation. The requirements in IEC 60364-6:2016 – 6.4.3.4 apply
- Insulation resistance/impedance of floors and walls. The requirements in IEC 60364-6:2016 - 6.4.3.5 apply
- Polarity test. The requirements in IEC 60364-6:2016 - 6.4.3.6 apply
- Testing to confirm effectiveness of automatic disconnection of supply. The requirements of the IEC 60364-6:2016 – 6.4.3.7 apply



Bharat Coking Coal Limited

Tender for Design, Engineering, Procurement & Supply, Construction & Erection, Testing, Commissioning, Associated Transmission System and Comprehensive O&M for 5 (Five) Years of 20 MW (AC)/28 MWp (DC) Solar PV Power Plant and connecting Transmission lines at Dugdha Washery, BCCL- Dhanbad



- Testing to confirm the effectiveness of additional protection. The requirements of the IEC60364-6:2016 – 6.4.3.8 apply.
- Test of phase sequence. The requirements of the IEC 60364-6:2016 – 6.4.3.9 apply
- Functional tests. The requirements of the IEC 60364-6:2016 – 6.4.3.10 apply
- Voltage drop. The requirements of the IEC 60364-6:2016 – 6.4.3.11 apply

Acceptance criteria

The AC commissioning will be passed when the aforementioned verifications are successfully passed in 100% of the sample according to the IEC 62446: 2016 – 5 and IEC 60364 – 6.

4.2.3 Additional Pre-Energizing Tests

All of the below tests shall be conducted in accordance with the supplier’s installation/commissioning manuals.

4.2.3.1 Distribution boards and combiner boxes Site

testing on distribution boards shall include:

- Mechanical functional test of all components including mechanical interlocks
- Electrical functional test of all control and protection wiring against the approved switchgear schematics
- Power frequency overvoltage test (flash test) on the switchgear including circuit-breakers in the test circuit
- Low resistance ductor test on the switchgear including circuit-breakers in the test circuit
- Visual inspection
- Verification of earthing

4.2.3.2 Inverters

Site testing on inverters shall include:

- Full test procedure as defined by the inverter manufacturer
- A full mechanical functional test of all components including mechanical interlocks
- Verification that the inverter operational parameters have been programmed to local regulations
- Electrical functional test of all control and protection wiring against the approved switchgear schematics as per approved MQP/FQP
- Insulation resistance test and earth residual current monitoring test

- Anti-islanding functionality
- High Voltage overvoltage test
- SCADA and metering calibration & functionality test

4.2.3.3 HT Switchgear

Site testing on outdoor circuit-breakers shall include:

- Functional check of all wiring, interlocks, auxiliaries and pressure devices
- Timing test and travel curve
- Visual inspection

4.2.3.4 LV/MV transformers

Transformer commissioning shall include:

- Visual inspection, alignment, earthing and labeling
- Functional check of all wiring against the approved transformer schematics
- Testing and calibration of all transformer protection and monitoring devices
- Insulation resistance test
- Functional test of off-circuit/on Circuit tap changer and check of the continuity of all windings

4.2.3.5 Substation/Power Transformers

- Ratio measurement on all tap changer settings
- Winding resistance measurement on highest, lowest and nominal tap settings
- Insulation resistance between all windings, and each winding to earth
- Insulation resistance core-to-earth
- Oil sample tests: breakdown strength, moisture content, and dissolved-gas content
- Transformer differential protection scheme testing

Acceptance criteria

The test results shall be aligned with the manufacturer specifications stated in the installation manual.

4.3 IV CURVE TESTING

The requirements of the IEC 62446-1:2016 – 7.2 apply. Following normative references shall be considered while performing the IV curve test:

- IEC 61829:2015 Photovoltaic (PV) array - On-site measurement of current-voltage characteristics



Bharat Coking Coal Limited

Tender for Design, Engineering, Procurement & Supply, Construction & Erection, Testing, Commissioning, Associated Transmission System and Comprehensive O&M for 5 (Five) Years of 20 MW (AC)/28 MWp (DC) Solar PV Power Plant and connecting Transmission lines at Dugdha Washery, BCCL- Dhanbad



- IEC 60891:2009 Photovoltaic devices - Procedures for temperature and irradiance corrections to measured I-V characteristics
- 3** % of the module strings shall be measured. If $\Delta P_{stringN} > 5\%$, all the modules within that string shall be I-V characterized. Modules with $\Delta P_N > 5\%$ shall be replaced. If more than 5% of the measured strings of the first sample show $\Delta P_N > 5\%$, another 2% shall be inspected. If more than 5% of the measured strings in the second sample show $\Delta P_N > 5\%$, another 5% shall be inspected. If more than 5% of the measured strings in the third sample show $\Delta P_N > 5\%$, another 10% shall be inspected. If more than 5% of the measured strings in the fourth sample show $\Delta P_N > 5\%$, another 10% shall be inspected. The reference power value is the flash list value minus the light induced degradation (LID) value in the datasheet/module warranty.

Acceptance criteria

The power determination analysis will be passed when less than 5% of the modules measured in the last sample show $\Delta P_N < 5\%$.



Bharat Coking Coal Limited

Tender for Design, Engineering, Procurement & Supply, Construction & Erection, Testing, Commissioning, Associated Transmission System and Comprehensive O&M for 5 (Five) Years of 20 MW (AC)/28 MWp (DC) Solar PV Power Plant and connecting Transmission lines at Dugdha Washery, BCCL- Dhanbad



5 Hot Commissioning

5.1 INFRARED INSPECTION

Following normative references apply:

- PV array infrared camera inspection procedure (IEC 62446-1:2016 - 7.3) and IEC 62446-3 TS Ed.1.0 - Photovoltaic (PV) systems - Requirements for testing, documentation and maintenance - Part 3: Outdoor infrared thermography of photovoltaic modules and plants(draft)

- The infrared inspection shall be applied both to the PV modules and the BOS components

The inspection sample will depend on the project size and shall be agreed with the OWNER. The following values serve as an orientation:

- Large scale ground mounted PV plants
 - PV modules: 100%
 - Inverters: 100%
 - Combiner boxes: 100%

Acceptance criteria

The following conditions shall be met simultaneously:

- 0.2% or less of the inspected modules show thermal gradients at the cell level of $T > 10\text{ K}$
- 0.2% or less of the inspected modules show thermal gradients at the junction box level of $T > 10\text{ K}$
- 0.2% or less of the inspected modules show inactive cell strings
- No PID is detected
- All module strings are connected and producing
- All inverters are connected and producing

5.2 INVERTER AVAILABILITY TEST

5.2.1 Calculation of the Operation Time

It shall be calculated on inverter level. The operation time starts as soon as the inverter switches on. Therefore only the logged irradiation values during the operation time of the inverter shall be considered. Irradiation values logged before or after the inverter running time shall be disregarded.



Bharat Coking Coal Limited

Tender for Design, Engineering, Procurement & Supply, Construction & Erection, Testing, Commissioning, Associated Transmission System and Comprehensive O&M for 5 (Five) Years of 20 MW (AC)/28 MWp (DC) Solar PV Power Plant and connecting Transmission lines at Dugdha Washery, BCCL- Dhanbad



5.2.2 Calculation of the Downtime

The downtime relevant for the availability calculation is any time in which a part or a subpart of the system is not operational. The outage periods shall be considered again on inverter level. Only complete outages shall be taken into consideration. System black-out periods due to following reasons shall not flow into the calculation (i.e. excluded events):

- A failure in the distribution grid or the transformer substation, making it impossible to transmit the generated power
- Solar radiation below the level needed to obtain the minimum operating voltage to start the inverter operation
- Causes of Force Majeure.
- Occurrences of anomalies in the power supply system (frequency differences or voltage surges) that trigger the protective systems of the plant or the limit settings of the inverter

Any forced disconnection shall be documented and recorded.

Acceptance criteria

The system availability shall be at least 99% during the testing period.

5.3 SINGLE AXIS TRACKER AVAILABILITY TEST (IF APPLICABLE)

The tracker availability test shall be carried out in parallel to the inverter availability test and shall have the same duration. During the test, all trackers shall follow the sun according to the angles established in the tracking mechanism. A loss of availability shall be considered when the angle of inclination of one or more trackers deviates by more than 2° from the theoretical angle. The angles of inclination of each tracker shall be recorded with a resolution of 1 min via the SCADA system.

Acceptance criteria

The tilt angle of each tracker shall lie within a ±2° range during 99.5% of the operational time.

5.4 SCADA AND WEATHER STATION RELIABILITY

5.4.1 Visual Inspection

- Installation of the communication system architecture diagram according to the specifications



Bharat Coking Coal Limited

Tender for Design, Engineering, Procurement & Supply, Construction & Erection, Testing, Commissioning, Associated Transmission System and Comprehensive O&M for 5 (Five) Years of 20 MW (AC)/28 MWp (DC) Solar PV Power Plant and connecting Transmission lines at Dugdha Washery, BCCL- Dhanbad



CNUL

- Functional Tests conducted during FAT for Pre-Dispatch Inspection shall be repeated.
- SCADA shall be linked to all protection relays, disturbance recorders and other substation equipment using the communications protocol
- Visual check on the assembly of all joints and on the as-installed condition of all components, including:
 - The irradiation sensor is not shaded and is installed at the correct tilt angle and under CCTV coverage.
 - Ambient temperature and module temperature sensor are installed properly (Reference IEC 61724)
 - Mechanical anchorage of the sensors is robust
- Complete calibration certificates of all the instruments shall be provided

Acceptance criteria

Each deviation from industrial best practices, norms, standards and good workmanship shall be documented in a punch list. The punch list shall represent a maximum budget of 1% of the construction price and all items shall be categorized as “critical”, “important” or “minor”.



Tender for Design, Engineering, Procurement & Supply, Construction & Erection, Testing, Commissioning, Associated Transmission System and Comprehensive O&M for 5 (Five) Years of 20 MW (AC)/28 MWp (DC) Solar PV Power Plant and connecting Transmission lines at Dugdha Washery, BCCL- Dhanbad

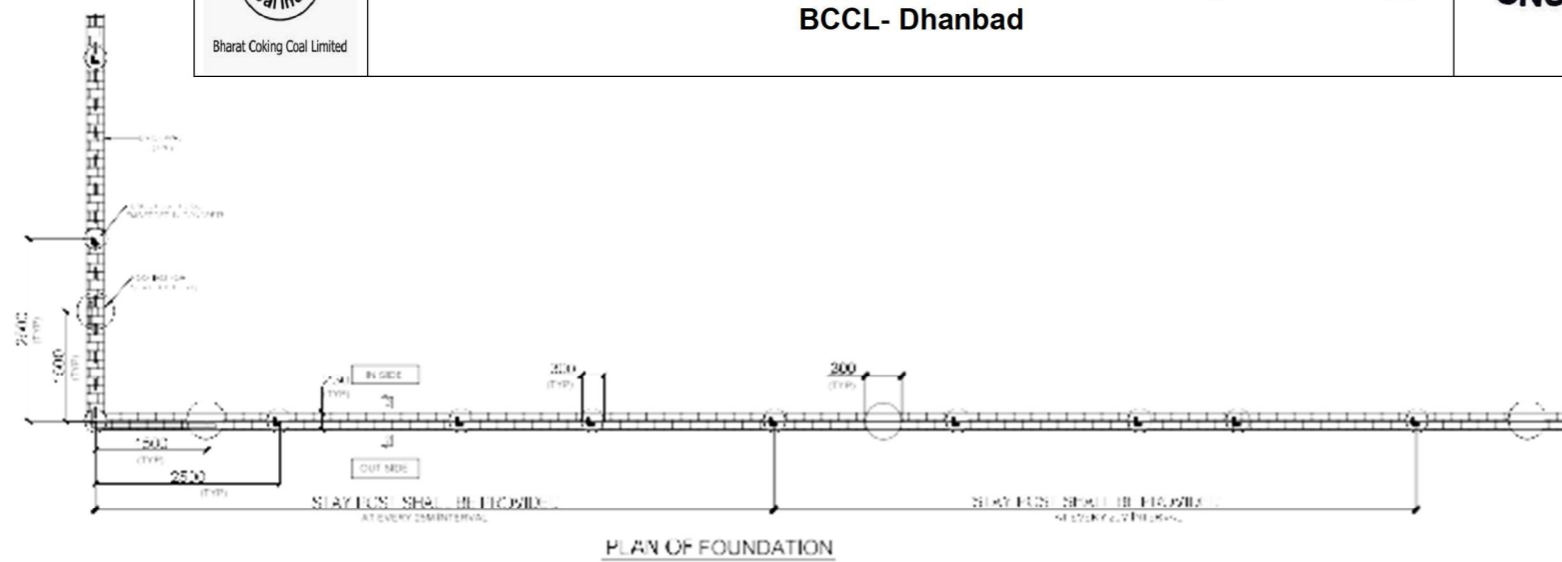

PLAN OF FOUNDATION

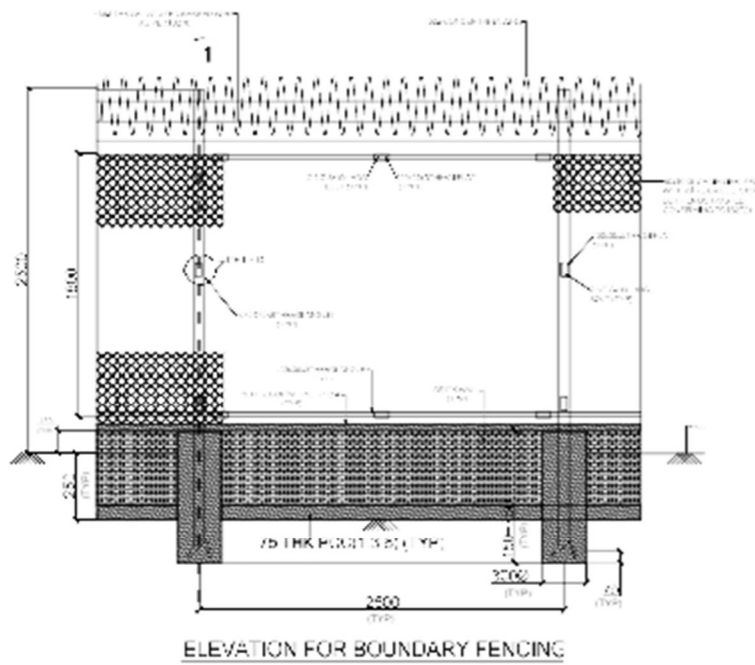

ELEVATION FOR BOUNDARY FENCING

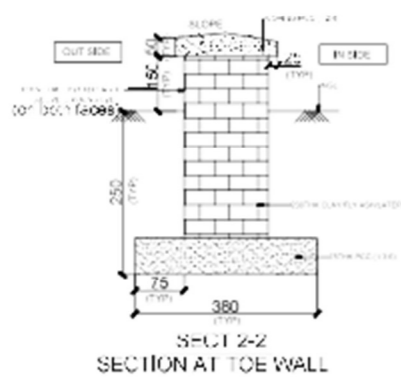

SECTION 2-2 SECTION AT TOE WALL

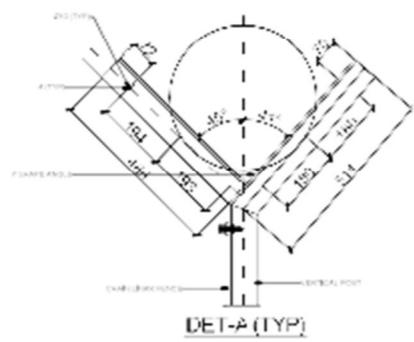

DET-A (TYP)

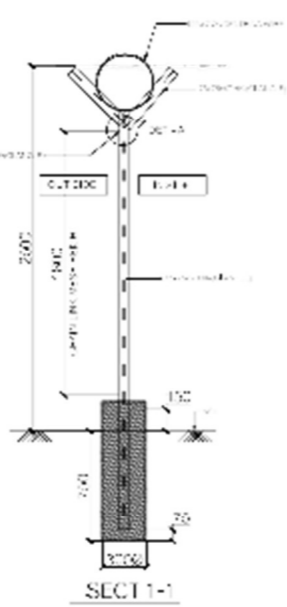

SECTION 1-1

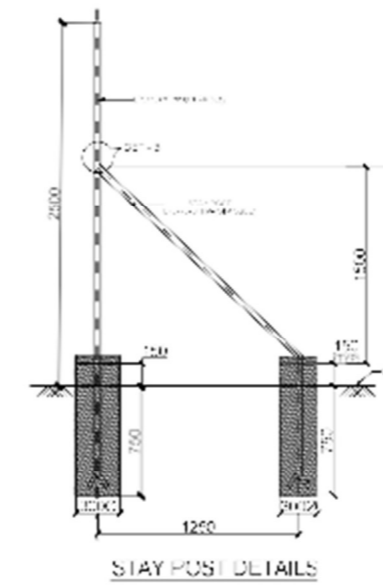

STAY POST DETAILS

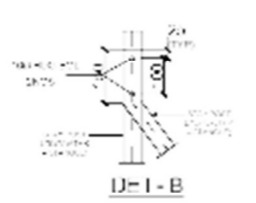

DETAIL B

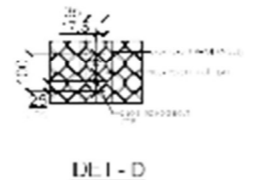

DETAIL D

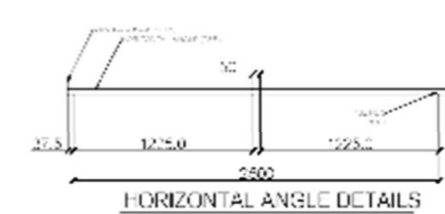

HORIZONTAL ANGLE DETAILS

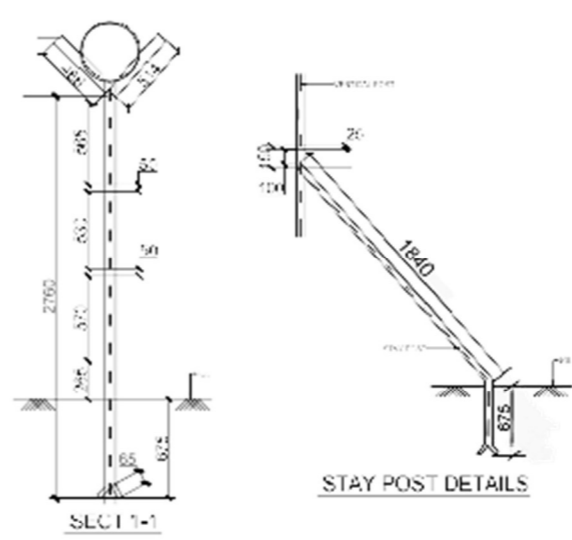

STAY POST DETAILS

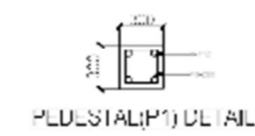

PEDESTAL (P) DETAILS

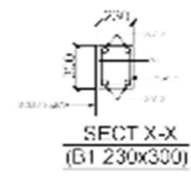

SECTION X-X (G.I. 230x330)

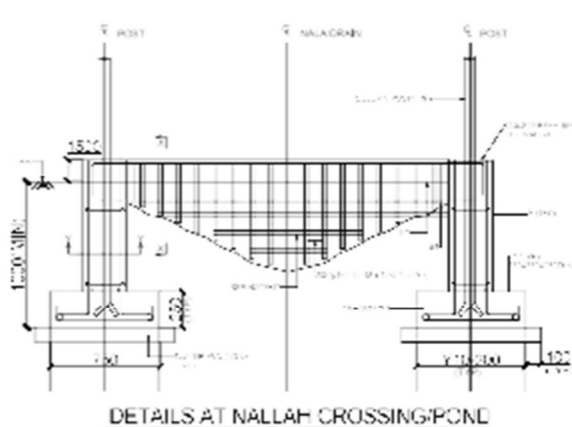

DETAILS AT NALLAH CROSSING POINT

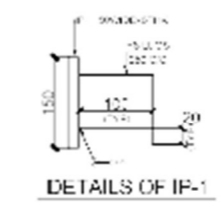

DETAILS OF IP-1

LEGEND

- PCC ——— PLAIN CEMENT CONCRETE
- NGL ——— NATURAL GROUND LEVEL
- DET ——— DETAIL
- TYP ——— TYPICAL
- HDG ——— HOT DIP GALVANIZED
- GI ——— GALVANIZED IRON
- Eq ——— EQUAL
- T&B ——— TOP & BOTTOM

NOTES

1. ALL DIMENSIONS ARE IN MILLIMETERS AND ELEVATION IN METERS.
2. ALL STRUCTURAL STEEL WORKS SHALL CONFORM TO IS 2062 GRADE-E250.
3. ALL DIMENSIONS TO BE CHECKED BEFORE FABRICATION OF STEEL WORK.
4. GALVANIZATION ON WIRES SHALL CONFORM TO IS 4826 HEAVY DUTY.
5. GALVANIZATION THICKNESS SHALL BE 80 MICRONS MIN.
6. FENCING HEIGHT SHALL FOLLOW THE NATURAL CONTOUR OF LAND.
7. BARBED WIRE SHALL BE OF MINIMUM 4MM DIA AND OF APPROVED MAKE. IT SHALL CONFORM TO IS 276.
8. THE BARBED WIRES SHALL BE INSERTED IN THE SLOTTED HOLE AND BOUND WITH BINDING WIRES.
9. TWO STAY POST SHALL BE PROVIDED AT EVERY CORNER COLUMN POST AND WHEREVER CHANGE IN ELEVATION/LEVEL EVERY TENTH INTERMEDIATE POST SHALL BE WITH A STAY POST.
10. GRADE OF CONCRETE SHALL BE M25 WITH 20MM NOMINAL SIZE GRADED AGGREGATES AS PER IS 456.
11. ALL REINFORCEMENT SHALL BE HIGH STRENGTH TMT BARS OF GRADE FE500D CONFORMING TO IS 1786.
12. CLEAR COVER TO REINFORCEMENT SHALL BE AS FOLLOWS: FOOTING = 50MM, COLUMN = 40MM & BEAM = 25MM.
13. HOLE DIAMETER SHALL BE 2MM LARGER THAN BOLT DIA.
14. A CURB OF 20MM SQ. EQ. TO MS BAR WITH 20 TO 15° AT SPACING OF 20MM ON WITH 20MM HORIZ. BARS OR 35MMX5MM THK FLAT WELDED TO VERTICAL SQ BARS AT SUITABLE INTERVALS (MIN. 3 NO OF THE BARS/FLATS) SHALL BE PROVIDED IN LIEU OF TOE WALL.
15. HEIGHT OF THE VERTICAL SQ SOLID MS BAR WILL VARY BASED ON ACTUAL NALLAH/DRAIN DEPTH.
16. POST ON EITHER SIDE OF NALA SHALL BE SUPPORTED WITH PEDESTAL & FOOTING ARRANGEMENT WITH A BEAM SPANNING ACROSS THE NALLAH/POND TO SUPPORT THE GRILLAGE AS SHOWN.
17. THE FOUNDATION OF THE STAY POSTS SHALL BE OF THE SAME SIZE AS THAT OF THE MAIN POSTS.
18. THE D-MESH FABRIC SHALL BE FIXED AT THREE POINTS EACH TO THE TOP AND BOTTOM EDGE USING 100x80x5 GI PLATE.
19. ALL PARTS SHALL BE PAINTED WITH QUALITY CHROME PIGMENT CHROME PRIMER.
20. ALL WELDS SHALL BE EVEN THICKNESS.
21. THROUGH HOLES IN 4MM THICK GALVANIZED WIRES SHALL BE FIXED TO EACH OTHER BY THE 4MM DIA WIRE SUPPLIERS HOLE WITH 4MM DIA WIRE THROUGH THE HOLES.

PROJECT CODE	PROJECT	DATE	SCALE
DRAWING NUMBER		DATE	SCALE
DRAWING NUMBER			
PROJECT CODE		PROJECT	SCALE
DRAWING NUMBER		DATE	SCALE
DRAWING NUMBER			

CHAH KR HD
DRAWING

A1



Bharat Coking Coal Limited

Tender for Design, Engineering, Procurement & Supply, Construction & Erection, Testing, Commissioning, Associated Transmission System and Comprehensive O&M for 5 (Five) Years of 20 MW (AC)/28 MWp (DC) Solar PV Power Plant and connecting Transmission lines at Dugdha Washery, BCCL- Dhanbad

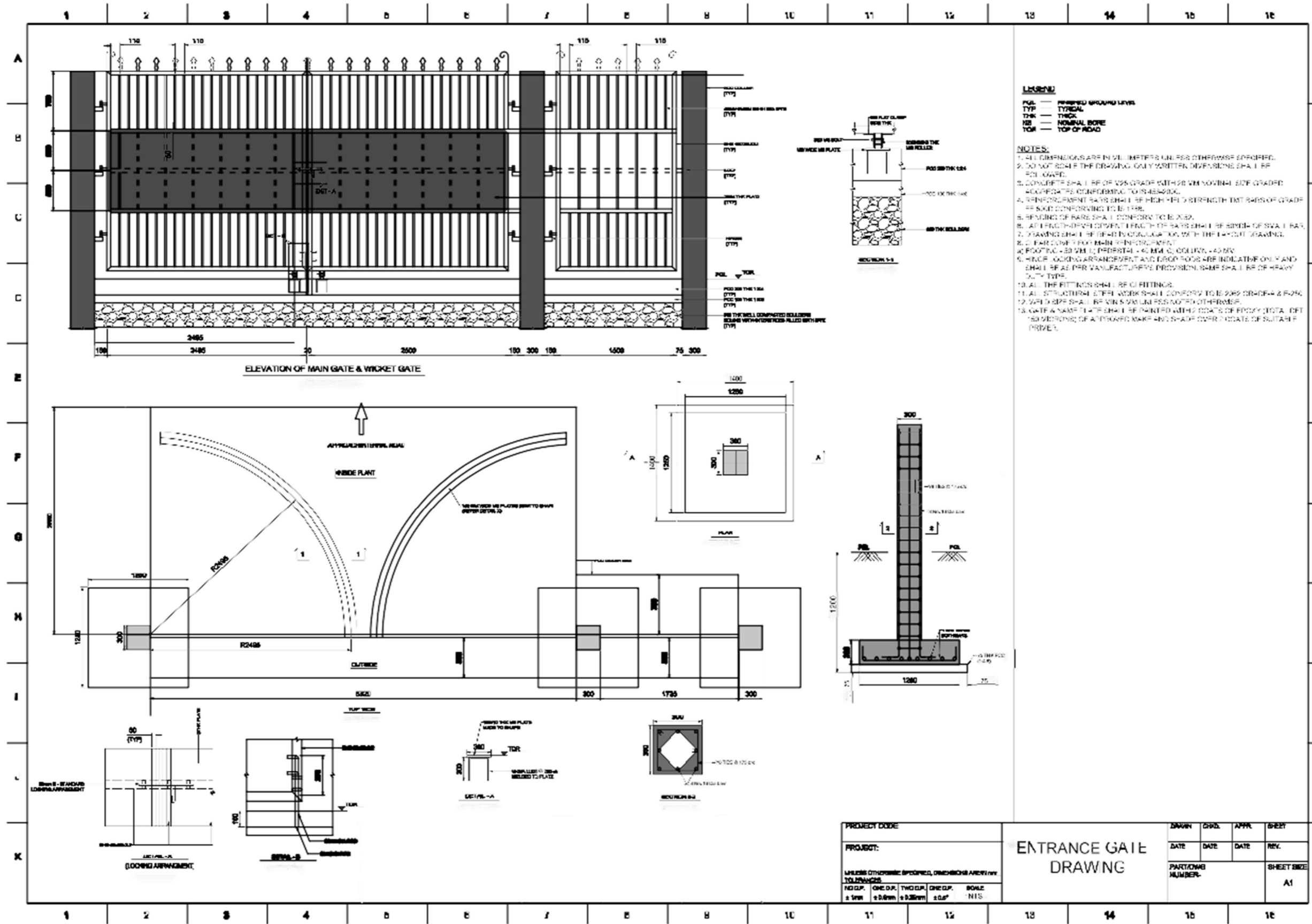



Bharat Coking Coal Limited

Tender for Design, Engineering, Procurement & Supply, Construction & Erection, Testing, Commissioning, Associated Transmission System and Comprehensive O&M for 5 (Five) Years of 20 MW (AC)/28 MWp (DC) Solar PV Power Plant and connecting Transmission lines at Dugdha Washery, BCCL- Dhanbad



CNUL